



AT&T

999-300-2611S

Enhanced Memory Expansion Board

User's Guide

©1986 AT&T
©1985 AST Research, Inc.
All Rights Reserved
Printed in USA

NOTICE

The information in this document is subject to change without notice. AT&T assumes no responsibility for any errors that may appear in this document.

Documentation for Simul-Task OS Merge is based on documentation used with permission of Locus Computing Corporation.

MS-DOS is a registered trademark of Microsoft Corporation. SuperPak, SuperDrive and SuperSpool are trademarks of AST Research, Inc.

UNIX is a trademark of AT&T.

IBM and VDISK are trademarks of International Business Machines, Inc.

Interference Information: Part 15 of FCC Rules

WARNING!

Federal Communications Commission (FCC) Rules require that you be notified of the following:

This equipment generates and uses radio frequency energy and if not installed and used properly, that is, in strict accordance within the manufacturer's instructions, may cause interference to radio and TV reception. It has been type-tested and found to comply with the limits for a Class B computing device in accordance with the specifications in Subpart J of Part 15 of FCC Rules, which are designed to provide reasonable protection against such interference in a residential installation. If this equipment does cause interference to radio or TV reception, which can be determined by turning the equipment off and on, the user is encouraged to try and correct the interference by one or more of the following measures:

Reorient the receiving TV or radio antenna where this may be done safely.

To the extent possible, relocate the receiver with respect to the computer equipment.

Where the computer equipment requires A.C. power, plug the computer equipment into a different A.C. outlet so that the computer equipment and receiver are on different branch circuits.

If necessary, the user should consult the AT&T IS representative or an experienced radio/television technician for additional suggestions. The user may find the following booklet "How to Identify and Resolve Radio-TV Interference Problems," helpful. The booklet, prepared by the Federal Communications Commission, is available from the U.S. Government Printing Office, Washington, D.C. 20402, Stock No. 004-000-00345-4.

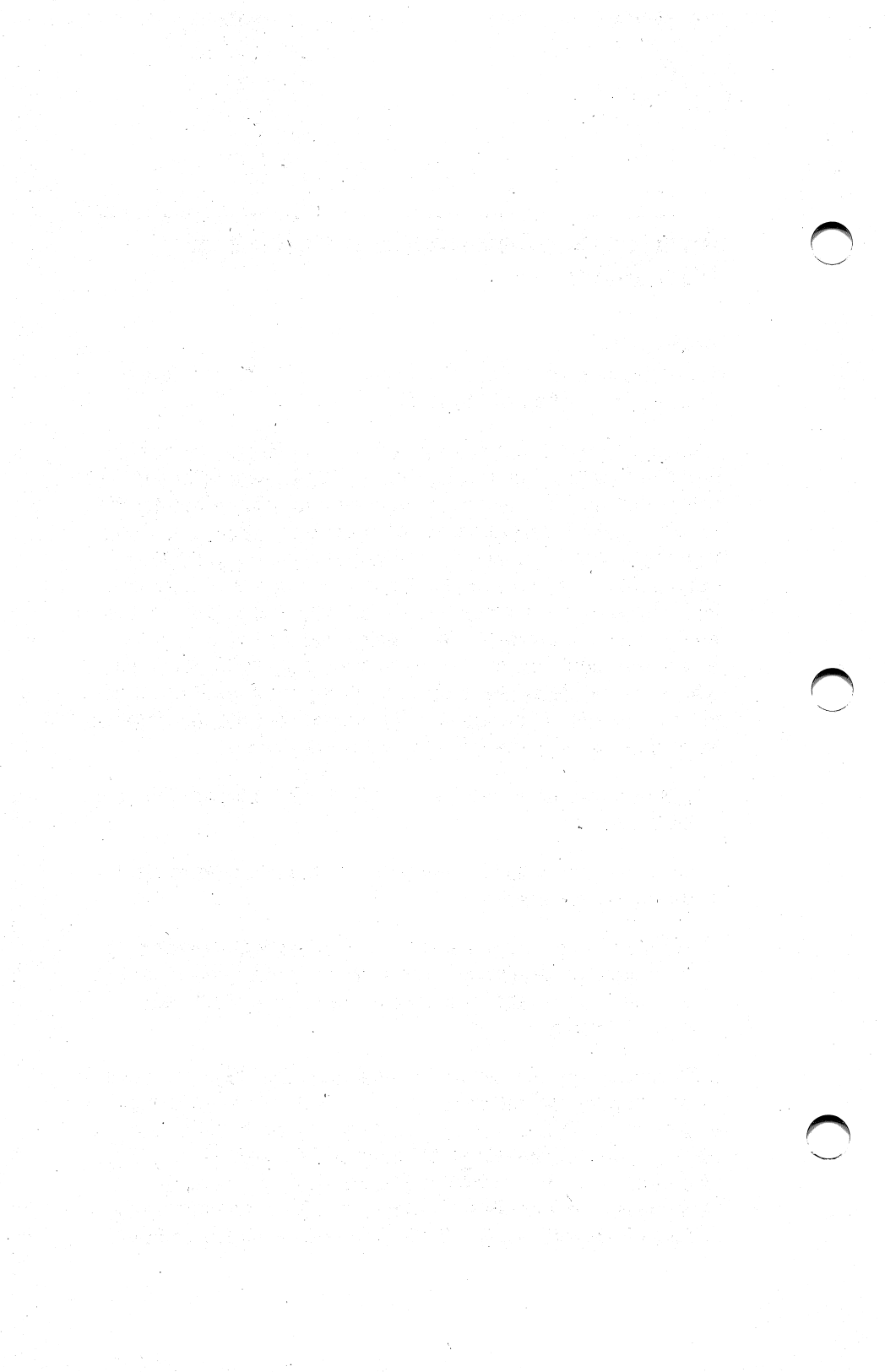

CONTENTS

SECTION 1. INTRODUCTION	1-1
1.1 Checklist	1-2
1.2 Features	1-2
1.3 System Requirements	1-4
1.4 How To Use This Manual	1-4
1.4.1 Format Notation	1-4
1.4.2 Related Documentation	1-5
SECTION 2. SOFTWARE AND HARDWARE CONFIGURATION FOR MS-DOS USE	2-1
SECTION 3. HARDWARE CONFIGURATION FOR UNIX ON A PC 6300 PLUS	3-1
SECTION 4. ENHANCED MEMORY EXPANSION BOARD INSTALLATION	4-1
4.1 Enhanced Memory Expansion Board Default Configuration	4-2
4.2 Installing the Enhanced Memory Expansion Board in Your PC 6300/PC 6300 PLUS	4-4
SECTION 5. HOW THE ENHANCED MEMORY EXPANSION BOARD WORKS	5-1
5.1 Memory Paging	5-1
5.2 AT&T Expanded Memory Manager (AEMM)	5-4
5.3 AT&T Extended Memory Emulator (AEX)	5-5
5.4 Extended Memory	5-6

CONTENTS (Continued)

APPENDIX A. ENHANCED MEMORY EXPANSION

	BOARD SWITCH SETTINGS	A-1
A.1	Memory Configuration	A-1
A.2	Configuring Memory For Use With the PC 6300 vs PC 6300 PLUS	A-8
A.3	Parity Error Checking	A-9
A.4	Increasing Memory Capacity on the Memory Board	A-9

APPENDIX B. MODIFYING YOUR MS-DOS CONFIG.SYS

	AND AUTOEXEC.BAT FILES	B-1
B.1	Text of Sample files	B-1
B.2	Modifying Your CONFIG.SYS File	B-3
	B.2.1 DEVICE = AEMM.SYS Parameters	B-3
	B.2.2 DEVICE = AEX.SYS Parameters	B-7
	B.2.3 Modifying CONFIG.SYS for Ramdisk	B-8

Figures

Figure 4-1.	Installation Overview	4-1
Figure 4-2.	Enhanced Memory Expansion Board Layout (Default Configuration)	4-2
Figure 4-3.	Turning Off the Power to the System (Rear View)	4-4
Figure 4-4.	Location of Cover Mounting Screws	4-5
Figure 4-5.	Sliding the Cover	4-6
Figure 4-6.	Removing the Cover	4-6
Figure 4-7.	PC 6300/PC 6300 PLUS Expansion Slots	4-7
Figure 4-8.	Removing the Expansion Slot Cover	4-8
Figure 4-9.	Installing the Memory Board	4-9
Figure 5-1.	Paging Technique (MS-DOS Only)	5-3
Figure 5-2.	Extended Memory	5-6

CONTENTS (Continued)

Figure A-1. Base I/O Address Settings	A-2
Figure A-2. Non-Paged Memory Size Configuration	A-3
Figure A-3. Switch Settings for Non-Paged Memory Already Installed	A-4
Figure A-4. DIP Shunt JP1 Location	A-8
Figure A-5. Parity Error Checking Settings	A-9
Figure A-6. Memory Configuration	A-11

Tables

Table 2-1. Sample Configurations	2-3
Table 3-1. Sample Configurations for UNIX Use	3-1
Table 4-1. Memory Board Default Configuration	4-3
Table A-1. Approved DRAM Manufacturers	A-10

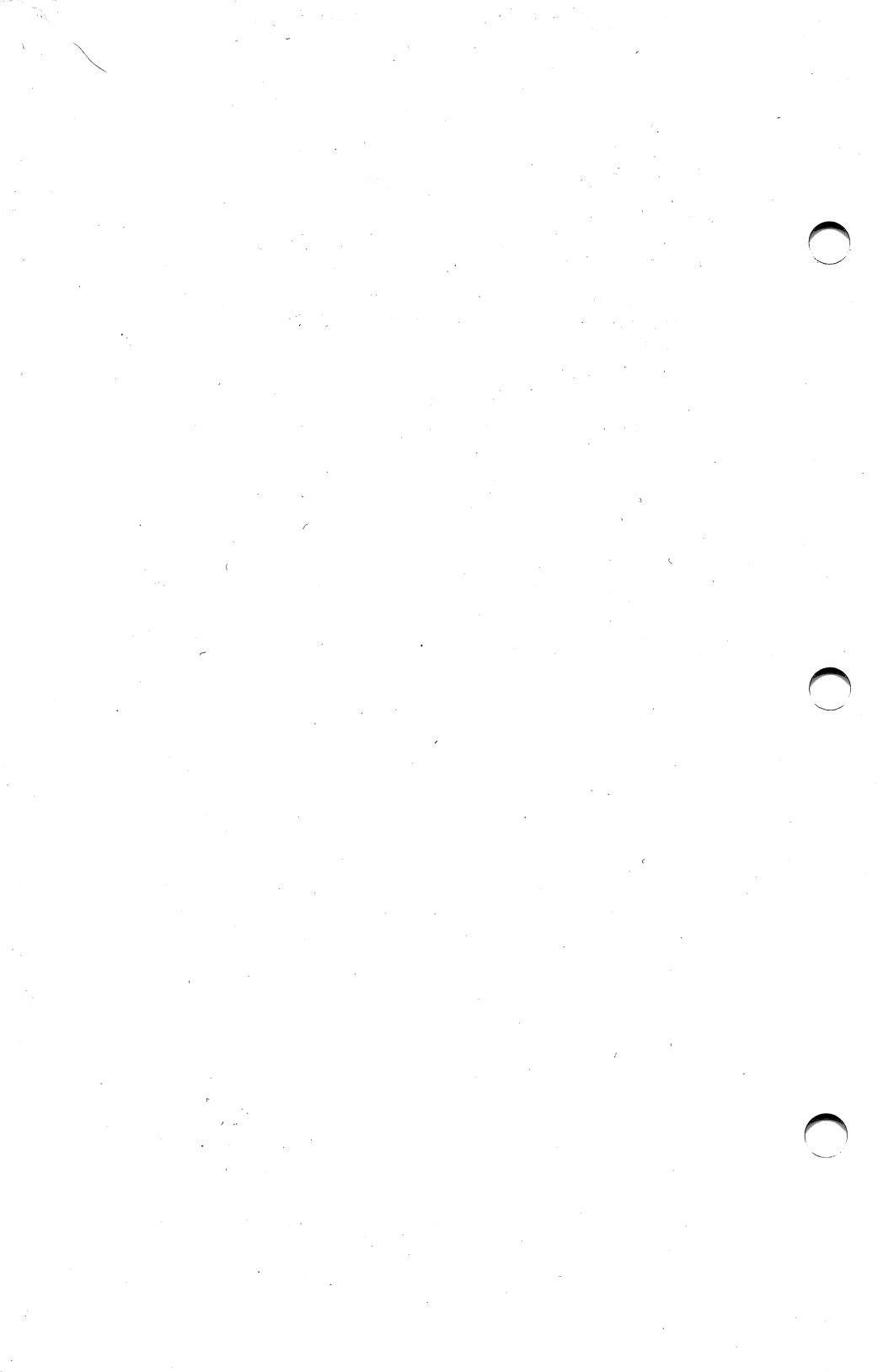

SECTION 1

INTRODUCTION

The AT&T Enhanced Memory Expansion Board represents a new generation of products to expand the capabilities of your AT&T Personal Computer 6300 (PC 6300) or AT&T Personal Computer 6300 PLUS (PC 6300 PLUS). The board enhances both the MS-DOS™ and UNIX™ operating system environments.

The PC 6300 and PC 6300 PLUS both support the MS-DOS operating system. Also, the PC 6300 PLUS supports the AT&T UNIX System V operating system. In addition, PC 6300 PLUS allows an MS-DOS program to execute under UNIX using the Simul-Task Operating System Merge feature.

Under MS-DOS, the memory board increases the capacity and improves the performance of:

- Applications that use AST Research's Enhanced Expanded Memory Specification (EEMS) or the Lotus/Intel/Microsoft Expanded Memory Specification software, including Lotus 1-2-3™ (release 2), Symphony™ (version 1.1), DESQview™ (version 1.1), and Framework II™, Concurrent PC-DOS™, AutoCAD™, and Ready!™.
- Applications that use RAM-based high speed temporary disk storage (RAMDISK).
- Print Spooling.

Under UNIX, the memory board increases the amount of memory and therefore improves performance. The UNIX system automatically takes advantage of the memory when the memory board is installed.

1.1 Checklist

Before getting started, check that your memory expansion package includes the following items:

- AT&T full-size Enhanced Memory Expansion board.
- A diskette labeled *Enhanced Memory Expansion Software Expanded Memory & SuperPak Programs*.
- The *AT&T Enhanced Memory Expansion Board User's Guide*.
- The *AT&T Enhanced Memory Board SuperPak User's Guide*.

1.2 Features

The Enhanced Memory Expansion board offers the following software and hardware features:

- Supports the following memory modes:

MS-DOS conventional memory—memory used to fill the PC 6300/PC 6300 PLUS system memory up to a maximum of 640 KB.

MS-DOS expanded memory—by using a technique called memory paging, the memory board allows your PC 6300/PC 6300 PLUS to use memory beyond the normal MS-DOS memory.

Extended memory—memory the PC 6300 PLUS microprocessor uses when it operates in protected mode (the *AT&T PC 6300 PLUS Hardware Reference Manual* provides further information on protected mode). The AT&T PC 6300 PLUS UNIX System V takes full advantage of extended memory.

- Supplies up to 2 megabytes (MB) of additional memory using one expanded memory board. You can install as many as three expanded memory boards in a single PC 6300/PC 6300 PLUS. This allows for up to 7 MB of UNIX memory (including the 1-MB of built in memory) or up to 6 MB of expanded memory for MS-DOS.
- The additional memory can start at any address on a 128 kilobyte (KB) boundary, from 0 to 16 MB.
- Additional memory may be installed in 512-KB increments.

The Enhanced Memory Expansion board software offers the following features to an MS-DOS user:

- The AT&T Expanded Memory Manager (AEMM) software driver, which allows you to use expanded memory with new versions of applications software that utilize expanded memory.
- The AT&T Extended Memory Emulator (AEX) software driver, which allows you to use *expanded* memory as *extended* memory. This allows you to dynamically reconfigure *expanded* memory as *extended* memory without having to remove the board and reset switches.
- SuperPak utilities, which include: SuperDrive™, a RAM floppy disk drive simulator; SuperSpool™, a RAM print spooler; and RAMDISK a RAM fixed disk simulator.

1.3 System Requirements

The minimum hardware requirements for MS-DOS operation with the Enhanced Memory Expansion board are:

- An Enhanced Memory Expansion board with a minimum of 512 KB of memory.
- An AT&T PC 6300 or PC 6300 PLUS with one floppy diskette drive and an unused two-connector expansion slot.

The minimum requirements for UNIX operation with the Enhanced Memory Expansion Board are:

- An Enhanced Memory Expansion board with a minimum of 512 KB of memory.
- A PC 6300 PLUS with a 1.2-MB floppy drive, 20-MB hard disk, and 1 MB of built in memory.

The memory board's software is compatible with MS-DOS, version 2.0 or later and AT&T's UNIX System V operating system.

1.4 How To Use This Manual

This subsection provides an outline of the format notation used throughout this manual and a list of related documentation.

1.4.1 Format Notation

The following command format notation is used in this manual:

- *Boldface* is used to indicate keyboard entries the user must make.

- *Uppercase characters* indicate items (such as commands) that you enter exactly as shown. However, you can enter those items in any combination of upper- or lowercase letters.
- *Lowercase letters* represent parameters that are defined by the user. While the user defines the parameters, they must satisfy the conditions of the command description.
- *Angle brackets (< >)* tell you to press a key. For example, < **Esc** > instructs you to press the “Esc” key. You do not have to press < **Enter** > unless you are specifically instructed to do so.
- *Square brackets ([])* indicate an optional term which is included or omitted in the command at your discretion. Do not enter the brackets.
- System prompts and messages are indicated in **color**.

1.4.2 Related Documentation

This manual assumes you are somewhat familiar with your operating system and PC 6300/PC 6300 PLUS hardware. You may find it useful to have some of the following documents available for reference:

- *AT&T Enhanced Memory Expansion Board Technical Reference Manual.*
- *AT&T Enhanced Memory Expansion Board SuperPak User's Guide.*
- *Getting Started With Your AT&T Personal Computer 6300 PLUS.*

- *AT&T Personal Computer 6300 User's Guide.*
- *AT&T Personal Computer 6300 Service Manual.*
- *AT&T Personal Computer 6300 GW BASIC Programmers Guide.*
- *AT&T Personal Computer 6300 System Programmer's Guide.*
- *AT&T Personal Computer 6300 Reference Manual.*
- *AT&T Personal Computer 6300 MS-DOS by Microsoft® User's Guide.*
- *UNIX System V Release 2.0 User's Guide*
- *Specification for an Expanded Memory Device Interface Product, Copyright© 1985 AST Research, 2121 Alton Avenue, Irvine, CA 92714.*
- *Enhanced Expanded Memory Product Software Interface Specification (EEMS). Copyright© 1985 AST Research, 2121 Alton Avenue, Irvine, CA 92714.*
- *The Lotus®/Intel®/Microsoft® Expanded Memory Specification for Hardware Vendors, Copyright 1985 Lotus Development Corporation, 55 Cambridge Avenue Cambridge, MA 02142.*

SOFTWARE AND HARDWARE CONFIGURATION FOR MS-DOS USE

Your software diskette contains sample AUTOEXEC.BAT and CONFIG.SYS files that you can incorporate onto your MS-DOS boot disk to operate or enhance the memory board's operation.

- An AUTOEXEC.BAT file contains a list of commands your operating system directs your PC 6300/PC 6300 PLUS to automatically execute when it boots from disk.
- A CONFIG.SYS file contains commands to configure your PC and install device drivers. These drivers make external devices (such as the Enhanced Memory Expansion board) work with MS-DOS.

The AT&T Expanded Memory Manager (AEMM) program *must* be loaded with the CONFIG.SYS file on your boot disk to use expanded memory. AEMM is not required if you will not use expanded memory, and may not be required if you will not be using the AEX.SYS program. See Section 5 for AEMM command parameters.

You can load the AT&T Extended Memory Emulator (AEX) with your CONFIG.SYS file to reconfigure the board's *expanded* memory as *extended* memory, without changing the board's switches. The ability to reconfigure the expanded memory allows you to change from using a program that supports *expanded* memory (such as DESQview Version 1.1) to allocating more expanded memory as *extended* memory (to create larger RAM disks, such as RAMDISK — without opening your PC 6300/PC 6300 PLUS).

If you use AEX, you must also use AEMM. AEX must follow AEMM in your CONFIG.SYS file. AEX is required if you plan to use the SuperPak utilities (or other programs that need to access extended memory, such as IBM's VDISK™ utility), or if you do not plan to reset hardware switches to reconfigure

expanded memory. See Section 5 for an AEX description and command parameters.

NOTE

Using AEX to override switch settings for expanded memory does not allow the memory board to see another extended memory device that might be installed below it, that is, if you are using more than one memory board. In such a case you must change the memory board's switch settings for non-paged memory size. Appendix A provides instructions for changing switch settings.

If you wish to know more about the AEMM and AEX software, Section 5 of this manual provides details on how the software works.

Follow this procedure to install the appropriate software on your MS-DOS boot diskette:

STEP 1

Back up the Enhanced Memory Expansion software diskette: Store the master diskette in a safe place. You can then use the master diskette to back up your software if your working diskette is lost or damaged.

STEP 2

Refer to the sample configurations in Table 2-1: You can use those configurations as a model to determine the contents of your CONFIG.SYS and AUTOEXEC.BAT files and DIP switch settings on the board.

STEP 3

Create/Modify CONFIG.SYS and AUTOEXEC.BAT: If you have an existing CONFIG.SYS and AUTOEXEC.BAT file, you may wish to add the new parameters to those files. If you copy the sample files directly to your boot diskette, you must rename the CONFIGxx.SYS file "CONFIG.SYS", and rename the AUTOEXxx.BAT file "AUTOEXEC.BAT" so that the files are recognized by the operating system at startup time.

Appendix A gives detailed explanations on DIP switch settings. Appendix B gives the text of the sample CONFIG.SYS and AUTOEXEC.BAT files.

STEP 4

Copy program files: Copy the appropriate program files to your MS-DOS boot diskette (such as AEMM.SYS and AEX.SYS).

STEP 5

Now you are ready to install the memory board: Refer to Section 4 of this manual for instructions on how to install your memory board.

Table 2-1. Sample Configurations.

Config-uration	Definitions & Requirements	Files
1A	Has 256 KB of conventional memory and a 512 KB memory board. Will use 384 KB of additional memory to round out conventional memory to 640 KB, and 128 KB as expanded memory. AEX will use the 128 KB of expanded memory to emulate extended memory. Extended memory will contain one 64-KB SuperSpool buffer.	AUTOEX1A.BAT CONFIG1A.SYS
		
	SW1	SW2

Table 2-1. Sample Configurations (Continued).

Config- uration	Definitions & Requirements	Files
1B	<p>Has 512 KB of conventional memory and a 512-KB memory board. Will use 128 KB of additional memory to round out conventional memory to 640 KB, and 384 KB as expanded memory. Extended memory can be used. AEX will use the 384 KB of expanded memory to emulate extended memory. Emulated extended memory will include one 360-KB SuperDrive and one 24-KB SuperSpool buffer.</p>	<p>AUTOEX1B.BAT CONFIG1B.SYS</p>
<div style="display: flex; justify-content: space-around; align-items: center;"> <div style="text-align: center;">  <p>SW1</p> </div> <div style="text-align: center;">  <p>SW2</p> </div> </div>		
2A	<p>Has 256 KB of conventional memory and a 2-MB expanded memory board. Will use 384 KB of additional memory to round out conventional memory to 640 KB, and all remaining memory (1664 KB) as extended memory. No expanded memory. No AUTOEXEC.BAT or CONFIG.SYS files are required.</p>	
<div style="display: flex; justify-content: space-around; align-items: center;"> <div style="text-align: center;">  <p>SW1</p> </div> <div style="text-align: center;">  <p>SW2</p> </div> </div>		

Table 2-1. Sample Configurations (Continued).



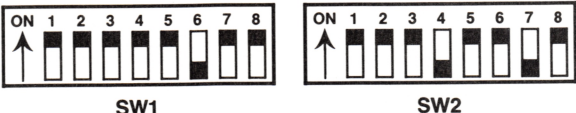

Config-uration	Definitions & Requirements	Files
2B	<p>Has 512 KB of conventional memory and a 2-MB memory board. Will use 128 KB of additional memory to round out conventional memory to 640 KB, and all remaining memory (1920 KB) as extended memory. No expanded memory. No AUTOEXEC.BAT or CONFIG.SYS files are required because SuperDrive and SuperSpool are not used.</p>	
<div style="display: flex; justify-content: space-around; align-items: center;"> <div style="text-align: center;">  <p>SW1</p> </div> <div style="text-align: center;">  <p>SW2</p> </div> </div>		
2C	<p>Has 256 KB of conventional memory and a 2-MB memory board. Uses 384 KB of additional memory to round out conventional memory to 640 KB. Allocates 640 KB as extended memory and the remaining 1 MB as expanded memory. AEX will use all 1 MB of expanded memory to emulate extended memory. Emulated extended memory is supported. Will include a 64-KB SuperSpool buffer and 576-KB RAMDISK volume.</p>	<p>CONFIG2C.SYS AUTOEX2C.BAT</p>
<div style="display: flex; justify-content: space-around; align-items: center;"> <div style="text-align: center;">  <p>SW1</p> </div> <div style="text-align: center;">  <p>SW2</p> </div> </div>		

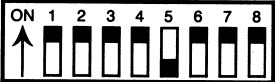
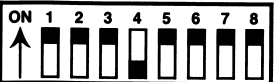
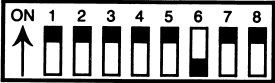
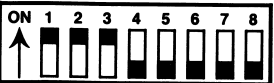
Table 2-1. Sample Configurations (Continued).

Config- uration	Definitions & Requirements	Files
2D	<p>Has 512 KB of conventional memory and a 2-MB memory board. Uses 128 KB of additional memory to round out conventional memory to 640 KB. Allocates 896 KB as extended memory and the remaining 1 MB as expanded memory. AEX will use 896 KB of the 1 MB of expanded memory to emulate extended memory. Emulated extended memory is supported. Will include a 64-KB SuperSpool buffer and a 832-KB RAMDISK volume.</p>	<p>CONFIG2D.SYS AUTOEX2D.BAT</p>
<div style="display: flex; justify-content: space-around; align-items: center;"> <div data-bbox="181 818 458 902"> <p style="text-align: center;">SW1</p> </div> <div data-bbox="487 818 763 902"> <p style="text-align: center;">SW2</p> </div> </div>		
2E	<p>Has 256 KB of conventional memory and a 2-MB memory board. Uses 384 KB of additional memory to round out conventional memory to 640 KB. Allocates the remaining expanded memory (1664 KB) as expanded memory. No extended memory is allocated. AEX will use 1664 KB of expanded memory to emulate extended memory. Emulated extended memory will include a 64-KB SuperSpool buffer and a 1600-KB RAMDISK volume.</p>	<p>CONFIG2E.SYS AUTOEX2E.BAT</p>
<div style="display: flex; justify-content: space-around; align-items: center;"> <div data-bbox="174 1344 451 1429"> <p style="text-align: center;">SW1</p> </div> <div data-bbox="479 1344 756 1429"> <p style="text-align: center;">SW2</p> </div> </div>		

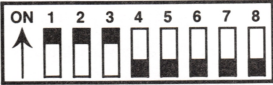
Table 2-1. Sample Configurations (Continued).

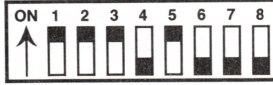
Config-uration	Definitions & Requirements Files	Files
2F	Has 512 KB of conventional memory and a 2-MB memory board. Uses 128 KB of additional memory to round out conventional memory to 640 KB. Allocates the remaining expanded memory (1920 KB) as expanded memory. No extended memory is allocated. AEX will use 1920 KB of expanded memory to emulate extended memory. Emulated extended memory will include a 64-KB SuperSpool buffer and a 1856-KB RAMDISK volume.	CONFIG2F.SYS AUTOEX2F.BAT
<div style="display: flex; justify-content: space-around; align-items: center;"> <div style="text-align: center;">  <p>SW1</p> </div> <div style="text-align: center;">  <p>SW2</p> </div> </div>		

If necessary, you can modify these sample files or add parameters to suit your needs.

(This page intentionally left blank)

SECTION 3

HARDWARE CONFIGURATION FOR UNIX USE ON A PC 6300 PLUS

The UNIX operating system does not require any special software configuration to utilize the Enhanced Memory Expansion board. When executing MS-DOS under UNIX using the Simul-Task Operating System Merge feature, refer to Section 2 for software configuration information. In this case, extended memory on the board will be used by UNIX, and any expanded memory will be available to MS-DOS programs under Simul-Task OS Merge.

Refer to the sample configurations in Table 3-1. You can use those configurations as a model to determine the DIP switch settings on the board. Appendix A gives detailed explanations of the DIP switch settings.

Table 3-1. Sample Configurations for UNIX Use.









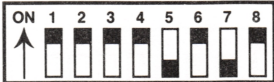

Config-uration	Sample Configuration
1	<p>Has 1 MB of built-in memory and a 512-KB memory board with extended memory only.</p> <div style="display: flex; justify-content: space-around;"><div style="text-align: center;"><p>SW1</p></div><div style="text-align: center;"><p>SW2</p></div></div>
2	<p>Has 1 MB of built-in memory and a 2-MB memory board with 1 MB defined as extended memory and 1 MB defined as expanded (paged) memory. Unix will have the use of 1 MB of memory (1 MB of built-in and 1 MB of extended memory on the board). MS-DOS software executing under UNIX using the Simul-Task OS Merge feature can use 1 MB of expanded memory.</p> <div style="display: flex; justify-content: space-around;"><div style="text-align: center;"><p>SW1</p></div><div style="text-align: center;"><p>SW2</p></div></div>

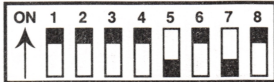
Table 3-1. Sample Configurations for UNIX Use (Continued).

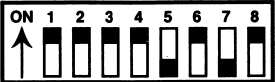
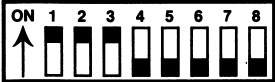
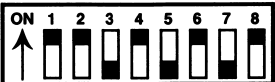
Configuration	Definitions & Requirements
3	<p>Has 1 MB of built in memory and two 2-MB memory boards with 3 MB defined as extended memory and 1 MB as expanded memory.</p>
Board 1	<div style="display: flex; justify-content: space-around;"> <div style="text-align: center;">  <p>SW1</p> </div> <div style="text-align: center;">  <p>SW2</p> </div> </div>
Board 2	<div style="display: flex; justify-content: space-around;"> <div style="text-align: center;">  <p>SW1</p> </div> <div style="text-align: center;">  <p>SW2</p> </div> </div>
4	<p>Has 1 MB of built in memory and three 2-MB memory boards with 6 MB defined as extended memory.</p>
Board 1	<div style="display: flex; justify-content: space-around;"> <div style="text-align: center;">  <p>SW1</p> </div> <div style="text-align: center;">  <p>SW2</p> </div> </div>
Board 2	<div style="display: flex; justify-content: space-around;"> <div style="text-align: center;">  <p>SW1</p> </div> <div style="text-align: center;">  <p>SW2</p> </div> </div>
Board 3	<div style="display: flex; justify-content: space-around;"> <div style="text-align: center;">  <p>SW1</p> </div> <div style="text-align: center;">  <p>SW2</p> </div> </div>

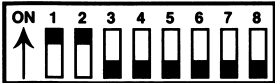
ENHANCED MEMORY EXPANSION BOARD INSTALLATION

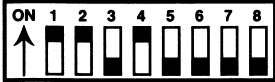
This section details the procedures used to configure and install the Enhanced Memory Expansion Board into your PC 6300 or PC 6300 PLUS.

Figure 4-1 summarizes the installation procedure.

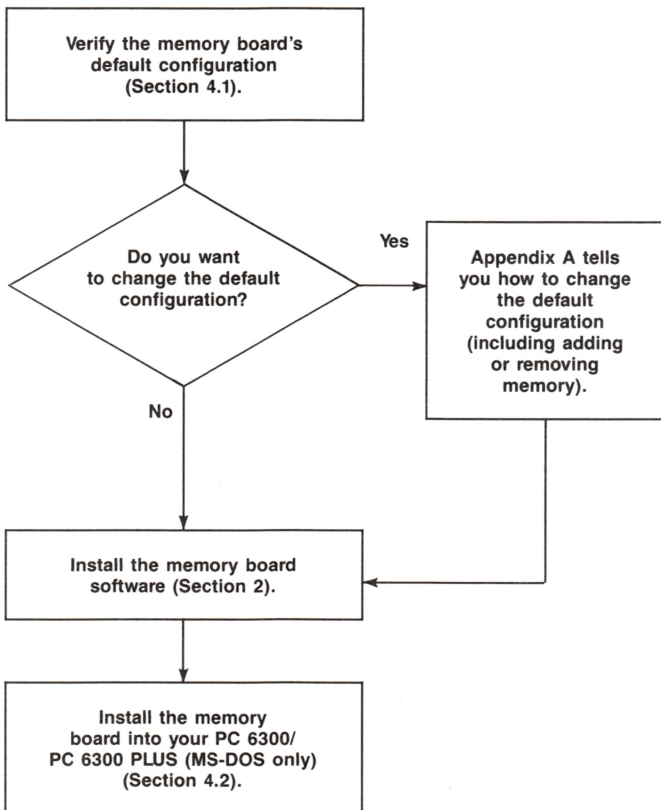

Figure 4-1. Installation Overview.

4.1 Enhanced Memory Expansion Board Default Configuration

Figure 4-2 shows the default configuration of the memory board. Appendix A gives further details on changing the factory default configuration.

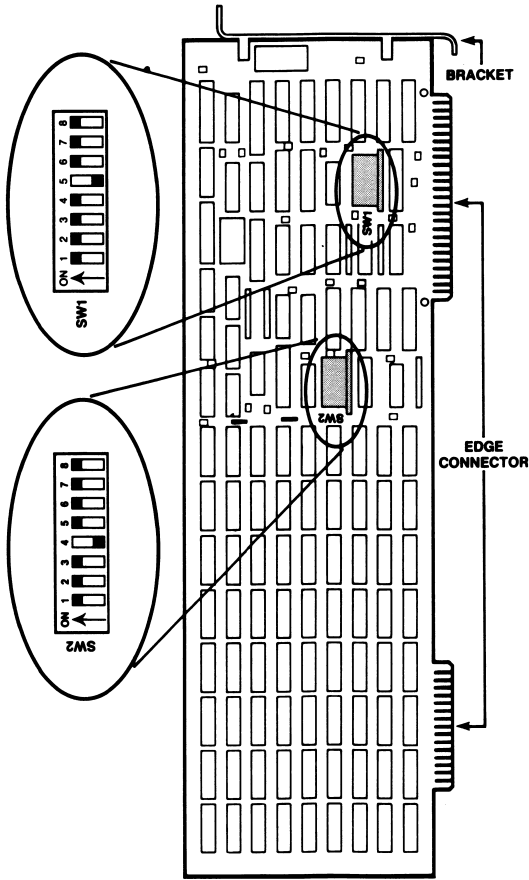

Figure 4-2. Enhanced Memory Expansion Board Layout (Default Configuration).

Table 4-1 summarizes the memory board's default configuration. This configuration is set up to accommodate a PC 6300 PLUS with 1 megabyte (MB) of memory on the motherboard.

Table 4-1. Memory Board Default Configuration.

Parameter	Default	Comments
Non-paged memory installed below	640 KB (SW1-1 ON SW1-2 ON SW1-3 ON SW1-4 ON SW1-5 OFF SW1-6 ON SW1-7 OFF)	This setting tells the hardware and software how much non-paged memory (conventional and extended memory) is already installed below this memory board. Do not change this setting unless your PC 6300/ PC 6300 PLUS has other than 640 KB of non-paged memory installed below this board.
Parity checking	Enabled (SW1-8 ON)	This setting enables or disables the parity memory error checking feature. To ensure maximum data integrity, do not disable parity.
Non-paged memory size	512 KB (SW2-5 ON SW2-6 ON SW2-7 OFF SW2-8 OFF)	This setting defines how much additional memory is allocated as non-paged memory. Any remaining memory is used as paged memory.
Base I/O address	0218-0219 (SW2-1 ON SW2-2 ON SW2-3 ON SW2-4 OFF)	The base I/O address setting tells your PC 6300/PC 6300 PLUS what addresses to use to communicate with the memory board. Do not change the default setting unless you are installing more than one memory board in your PC 6300/PC 6300 PLUS, or there is another device in your PC 6300/PC 6300 PLUS which uses the same I/O address range.

4.2 Installing the Enhanced Memory Expansion Board in Your PC 6300/PC 6300 PLUS

STEP 1

Power off the computer: Power off the computer and all of the equipment connected to it (Figure 4-3). Before disconnecting all of the cables attached to the rear of the unit, note their locations.

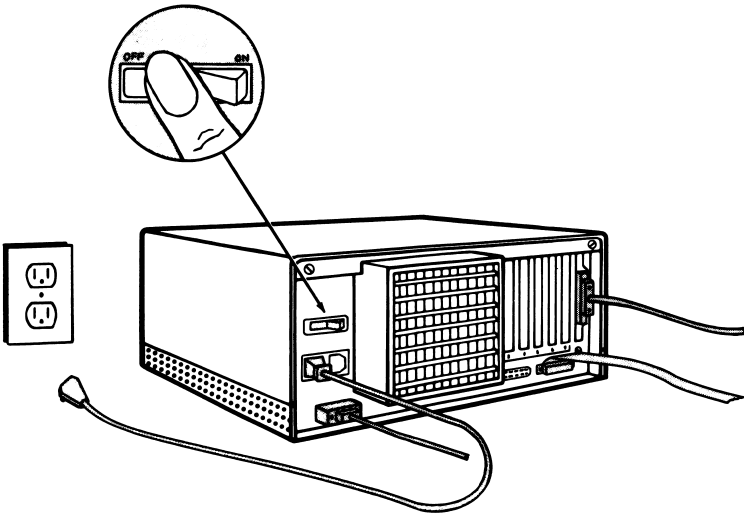

Figure 4-3. Turning Off the Power to the System (Rear View).

STEP 2

Remove the cover: Loosen the cover mounting screws on the computer's rear panel (Figure 4-4) using a flat-blade screwdriver. Partially unscrew them (approximately a quarter of an inch) until they are very loose.

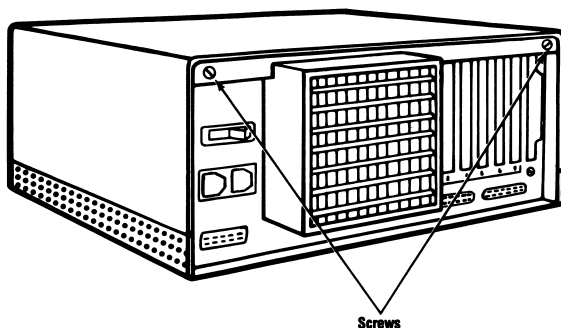

Figure 4-4. Location of Cover Mounting Screws.

STEP 3

Slide the cover: Standing in front of the unit, firmly slide the cover toward you (Figure 4-5). The cover is designed to fit very tightly, so it may take some effort to slide it out of its normal position. If the cover does not move, you may have to loosen the screws some more.

Once you have moved the cover about one-eighth of an inch toward the front of the unit, the cover may be lifted from the metal base.

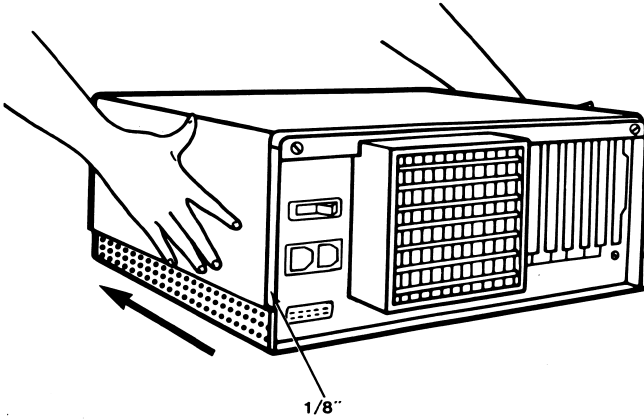

Figure 4-5. Sliding the Cover.

STEP 4

Remove the cover: Keep your hands on the sides of the cover and tilt it so that the rear section is higher than the front as shown in Figure 4-6. Lift the cover from the base and set it aside.

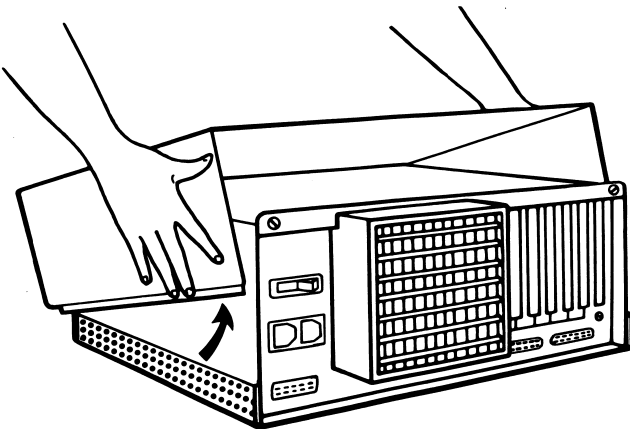

Figure 4-6. Removing the Cover.

STEP 5 *Select an unused full length expansion slot:* Since the memory board requires a full length expansion slot, use slot 1, slot 2, or slot 3. Note that some PC 6300 models have only two expansion slots. In this case, use slot 1 or slot 2.

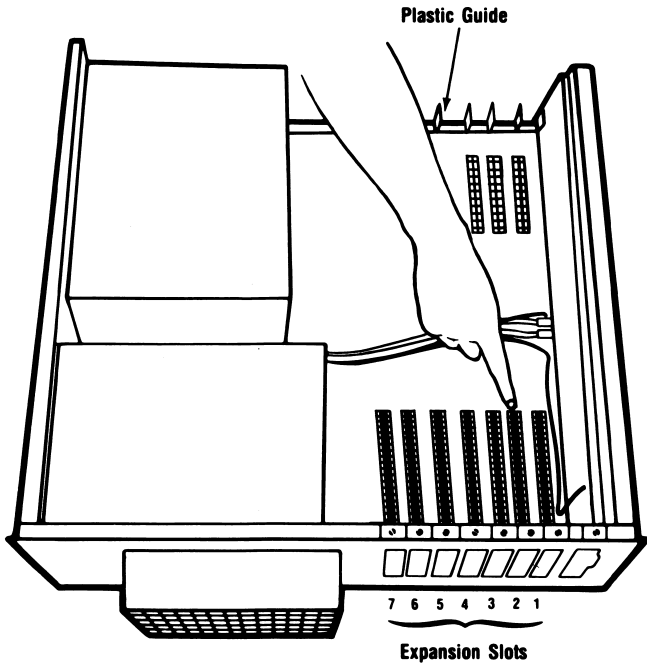

Figure 4-7. PC 6300/PC 6300 PLUS Expansion Slots.

STEP 6

Remove the expansion slot cover: Using a flat blade screwdriver, remove and save the bracket retaining screw that holds the metal expansion slot cover (Figure 4-8). Remove the slot cover.

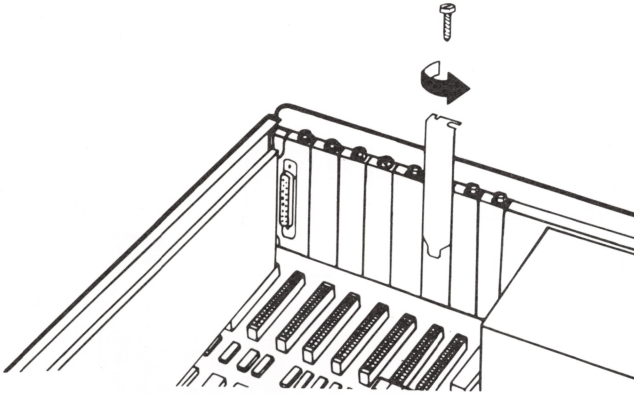

Figure 4-8. Removing the Expansion Slot Cover.

STEP 7

Install the board: Move the colored wires that cross the expansion slot away from the slot itself. Position the wires so that they will be either beneath or above the card when it is installed.

Arrange the board inside the chassis. Align the board's edge connectors with the expansion slot receptacle. Use an evenly distributed pressure to insert the board straight down until it seats in the expansion slot (Figure 4-10).

Install the bracket retaining screw that you removed in step 6 to secure the board's bracket to the rear of the PC chassis.

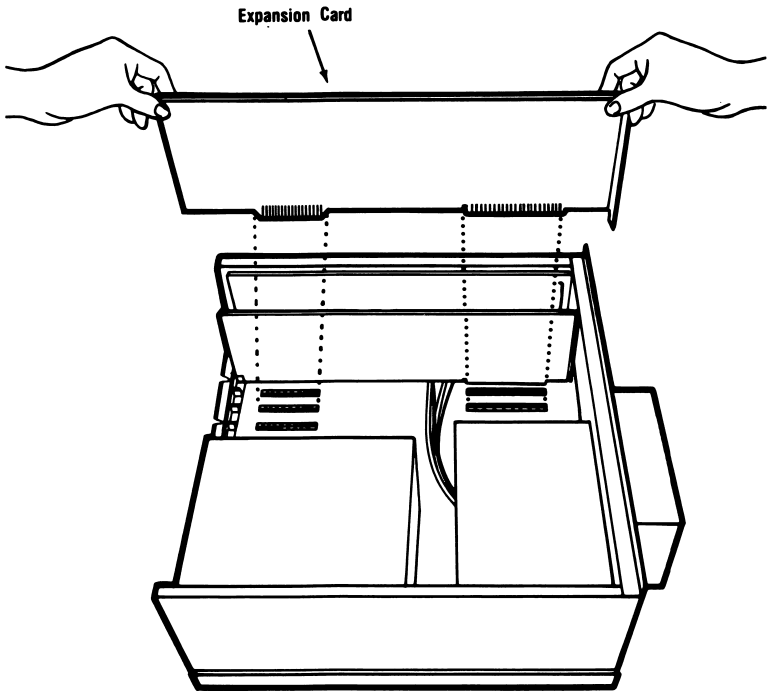

Figure 4-9. Installing the Memory Board.

STEP 8

Replace the cover: Carefully slide the cover from the front until it stops securely against the rear panel. Tighten the cover mounting screws.

Enhanced Memory Expansion Board Installation

STEP 9

Replace the power cord to the system unit: Make sure that the keyboard and CRT connectors are plugged in securely.

STEP 10

Now you are ready to use the board. Follow the procedures for booting the operating system.

HOW THE ENHANCED MEMORY EXPANSION BOARD WORKS

This section presents an overview of how the Enhanced Memory Expansion Board works, discusses memory paging, and describes the software for MS-DOS use and extended memory use. Although you do not need this information to use the memory board, this section is provided for those who want some background on how the product functions. For more detailed information, see the *AT&T Enhanced Memory Expansion Board Technical Reference Manual*.

5.1 Memory Paging

By using a technique called *memory paging*, the memory board allows your PC 6300/PC 6300 PLUS to use *expanded memory* — memory beyond the normal PC 6300/PC 6300 PLUS memory map. Expanded (paged) memory supports expanded memory multitasking programs that are compatible with the Enhanced Expanded Memory Specification (EEMS), such as DESQview Version 1.1 (which allows your PC 6300/PC 6300 PLUS to run several programs at once) and expanded memory applications software such as Framework II or Lotus 1-2-3 (or later EEMS-compatible versions of these programs).

The PC 6300 can address up to 1 megabyte (MB) of memory and the PC 6300 PLUS can address up to 16 MB of memory. The normal memory map (shown in Figure 5-1) allocates the first 640 kilobytes (KB) of memory as conventional memory. The memory from 1 to 16 MB (which is accessed when running the PC 6300 PLUS in Protected mode) is called extended memory. PC 6300/PC 6300 PLUS memory between 640 KB and 1 MB is used for housekeeping functions such as video memory.

Each memory board can contain up to 2 MB of physical memory. Expanded physical memory is divided into 16-KB blocks called *pages*. AT&T expanded memory software (along

with your expanded memory applications software) swaps memory pages in and out of open *windows* in the unused areas between 640 KB and 1 MB. This software can also swap memory pages into expanded memory that is addressed anywhere in the 0 to 16 MB range.

This memory paging process allows your PC 6300/PC 6300 PLUS to access expanded physical memory (up to 2 MB per board) at RAM speeds, completely transparent to the user. Software access to the paging hardware is provided by input/output (I/O) addresses designated by DIP switch settings on the board.

You can allocate any portion of additional memory as non-paged memory anywhere on a 128-KB boundary (except for the area between 640 KB and 1 MB) in the PC 6300/PC 6300 PLUS address space. Whatever expanded memory is not used as non-paged memory will be used by the AEMM software (if installed) as paged memory.

How the Enhanced Memory Expansion Board Works

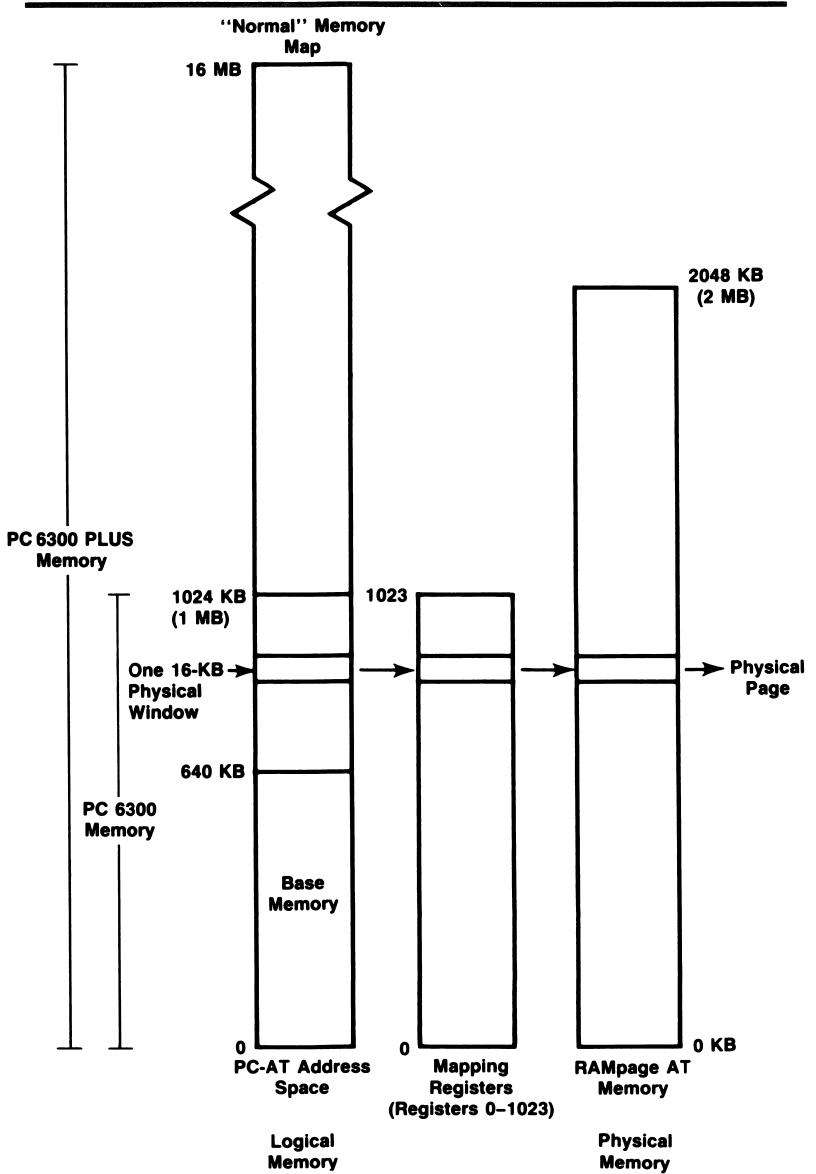

Figure 5-1. Paging Technique (MS-DOS Only).

5.2 AT&T Expanded Memory Manager (AEMM)

The AEMM software driver swaps memory between the expanded memory and PC 6300/PC 6300 PLUS memory by creating pointers, loading the registers, and mapping PC 6300/PC 6300 PLUS windows to expanded memory. AEMM also conducts an integrity test on the expanded memory when the PC 6300/PC 6300 PLUS is turned on and prevents any expanded memory that is not working properly from being used.

Your expanded memory applications program must keep track of what page of expanded memory holds a particular element of data, in order to retrieve it. According to parameters supplied by the expanded memory software, AEMM links windows in logical PC 6300/PC 6300 PLUS memory to pages of expanded physical memory by means of the 1024 Mapping registers, the Map Control register and the Page registers.

AEMM also allocates expanded memory to several *Process IDs*, also known as Expanded Memory Manager Handles. One or more Process IDs are allocated to a particular applications program, and each Process ID has certain pages of memory allocated to it. Process IDs aid in multitasking.

Before memory mapping is enabled, AEMM automatically maps any of the 16-KB pages that will be used to fill out the 640 KB of conventional memory. Addressing expanded memory as conventional memory provides additional performance improvements with Enhanced EMS operating environment software such as DESQview. Appendix B describes AEMM.SYS parameters.

5.3 AT&T Extended Memory Emulator (AEX)

AEX interfaces with the AEMM program to make expanded memory function like PC 6300 PLUS extended memory to the MS-DOS operating system.

AEX allows you to run the SuperPak utilities — SuperDrive, SuperSpool, and RAMDISK, which expect to use extended memory *even when you've set the board switches to allocate all memory as expanded (paged) memory.*

NOTE

AEX must be installed after AEMM, and AEX cannot function without AEMM. Using AEX to override switch settings for expanded memory does not allow the board to see another extended memory device that might be installed below it. In such a case, you must change the switch settings for non-paged memory size.

AEX intercepts calls on read-only memory basic input/output system (ROM BIOS) functions designed for extended memory use, and interfaces them to the AEMM software so that they can use the enhanced expanded memory.

As with applications that use the AEMM software, program code portions of the SuperPak programs must reside in the 640 KB of PC 6300/PC 6300 PLUS memory. However, data associated with SuperPak utilities can use enhanced expanded memory.

5.4 Extended Memory

Extended memory is a continuation of built-in memory. In the PC 6300 PLUS, the built-in memory is addressed in two segments: 0 to 640 KB, and (16 MB minus 384 KB) to 16 MB. The memory segment from 640 KB to 1 MB is used for housekeeping functions (for example, video memory) and is “invisible” for any other use. Extended memory is addressed starting at 1 MB. Figure 5-2 illustrates built-in and extended memory.

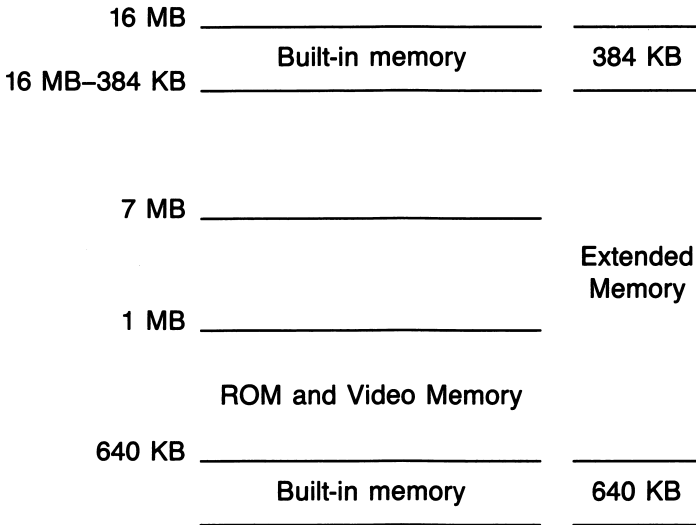

Figure 5-2. Extended Memory.

ENHANCED MEMORY EXPANSION BOARD SWITCH SETTINGS

This appendix tells you how to change the default configuration on the Enhanced Memory Expansion board.

- Section A.1 tells you how to change the memory configuration, including: *base I/O address, non-paged memory already installed, and non-paged memory size configuration.*
- Section A.2 tells you how to configure memory for use with the PC 6300 since memory comes configured for use with the PC 6300 PLUS.
- Section A.3 tells you how to enable or disable *parity error checking.*
- Section A.4 tells you how to increase the amount of expanded memory. Figure A-6 shows the locations of the Dual In-Line Process (DIP) switches and memory banks on the board.

NOTE

All switch illustrations show the DIP switches as viewed from the top of the board (as if it were installed in your system).

A.1 Memory Configuration

The memory configuration is determined as follows:

Base I/O address: SW2-1 through SW2-4 defines the base I/O address for MS-DOS use (the address the PC 6300/PC 6300 PLUS uses to communicate with the expanded memory) as shown in Figure A-1.

Enhanced Memory Expansion Board Switch Settings

Each setting designates a group of I/O addresses so the software can access paging hardware. Namely, when you select base I/O address 0208, the memory board uses addresses 0208, 4208, C208, 0209, 4209, and 8209. When you select base I/O address 0218, the memory board uses addresses 4218, 8218, C218, 0219, 4219, 8219, and so forth.

If you use more than one memory board in your PC 6300 or PC 6300 PLUS, each board must use a different base I/O address.

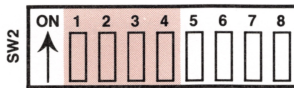

Base I/O Address	SW2-1	SW2-2	SW2-3	SW2-4
0208	ON	ON	ON	ON
*0218	ON	ON	ON	OFF
0228	ON	ON	OFF	ON
0238	ON	ON	OFF	OFF
0248	ON	OFF	ON	ON
0258	ON	OFF	ON	OFF
0268	ON	OFF	OFF	ON
0278	ON	OFF	OFF	OFF
0288	OFF	ON	ON	ON
0298	OFF	ON	ON	OFF
02A8	OFF	ON	OFF	ON
02B8	OFF	ON	OFF	OFF
02C8	OFF	OFF	ON	ON
02D8	OFF	OFF	ON	OFF
02E8	OFF	OFF	OFF	ON
02F8	OFF	OFF	OFF	OFF

*Default Setting

Figure A-1. Base I/O Address Settings.

Non-paged memory size: SW2-5 through SW2-8 defines how much expanded memory (if any) is available for allocation as non-paged memory as shown in Figure A-2. If no memory is to be used as non-paged memory (for example, SW1-1 through SW1-7 OFF), the settings in Figure A-3 will be ignored.

NOTE

Non-paged memory includes both conventional and extended memory. Although you can use AEX to reconfigure expanded memory as extended memory, *you cannot override the setting for non-paged memory size to allocate extended memory as expanded memory.*

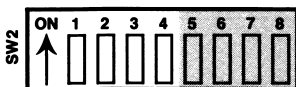

Amount of Non-Paged Memory	SW2-5	SW2-6	SW2-7	SW2-8
128 KB	ON	ON	ON	ON
256 KB	ON	ON	ON	OFF
384 KB	ON	ON	OFF	ON
*512 KB	ON	ON	OFF	OFF
640 KB	ON	OFF	ON	ON
768 KB	ON	OFF	ON	OFF
896 KB	ON	OFF	OFF	ON
1024 KB	ON	OFF	OFF	OFF
1152 KB	OFF	ON	ON	ON
1280 KB	OFF	ON	ON	OFF
1408 KB	OFF	ON	OFF	ON
1536 KB	OFF	ON	OFF	OFF
1664 KB	OFF	OFF	ON	ON
1792 KB	OFF	OFF	ON	OFF
1920 KB	OFF	OFF	OFF	ON
2048 KB	OFF	OFF	OFF	OFF

*Default setting

Figure A-2. Non-paged Memory Size Configuration.

Non-paged memory installed below: SW1-1 through SW1-7 (shown in Figure A-3) tells the hardware and software how much non-paged random access memory (RAM) is installed below this memory board. This prevents parity errors at power-up time, during memory sizing.

CAUTION

To prevent memory conflicts, make sure that the setting for non-paged memory already installed does not conflict with any add-on memory installed in your PC 6300/PC 6300 PLUS.

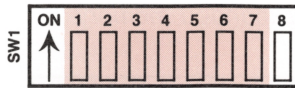

Non-Paged Memory Installed Below	SW1-1	SW1-2	SW1-3	SW1-4	SW1-5	SW1-6	SW1-7
0 KB	ON	ON	ON	ON	ON	ON	ON
128 KB	ON	ON	ON	ON	ON	ON	OFF
256 KB	ON	ON	ON	ON	ON	OFF	ON
384 KB	ON	ON	ON	ON	ON	OFF	OFF
512 KB	ON	ON	ON	ON	OFF	ON	ON
640 KB*	ON	ON	ON	ON	OFF	ON	OFF
768 KB	ON	ON	ON	ON	OFF	OFF	ON
896 KB	ON	ON	ON	ON	OFF	OFF	OFF
1024 KB	ON	ON	ON	OFF	ON	ON	ON
1152 KB	ON	ON	ON	OFF	ON	ON	OFF
1280 KB	ON	ON	ON	OFF	ON	OFF	ON
1408 KB	ON	ON	ON	OFF	ON	OFF	OFF
1536 KB	ON	ON	ON	OFF	OFF	ON	ON
1664 KB	ON	ON	ON	OFF	OFF	ON	OFF
1792 KB	ON	ON	ON	OFF	OFF	OFF	ON
1920 KB	ON	ON	ON	OFF	OFF	OFF	OFF

Figure A-3. Switch Settings for Non-Paged Memory Already Installed.

Non-Paged Memory Installed Below	SW1-1	SW1-2	SW1-3	SW1-4	SW1-5	SW1-6	SW1-7
2048 KB	ON	ON	OFF	ON	ON	ON	ON
2176 KB	ON	ON	OFF	ON	ON	ON	OFF
2304 KB	ON	ON	OFF	ON	ON	OFF	ON
2432 KB	ON	ON	OFF	ON	ON	OFF	OFF
2560 KB	ON	ON	OFF	ON	OFF	ON	ON
2688 KB	ON	ON	OFF	ON	OFF	ON	OFF
2816 KB	ON	ON	OFF	ON	OFF	OFF	ON
2944 KB	ON	ON	OFF	ON	OFF	OFF	OFF
3072 KB	ON	ON	OFF	OFF	ON	ON	ON
3200 KB	ON	ON	OFF	OFF	ON	ON	OFF
3328 KB	ON	ON	OFF	OFF	ON	OFF	ON
3456 KB	ON	ON	OFF	OFF	ON	OFF	OFF
3584 KB	ON	ON	OFF	OFF	OFF	ON	ON
3712 KB	ON	ON	OFF	OFF	OFF	ON	OFF
3840 KB	ON	ON	OFF	OFF	OFF	OFF	ON
3968 KB	ON	ON	OFF	OFF	OFF	OFF	OFF
4096 KB	ON	OFF	ON	ON	ON	ON	ON
4224 KB	ON	OFF	ON	ON	ON	ON	OFF
4352 KB	ON	OFF	ON	ON	ON	OFF	ON
4480 KB	ON	OFF	ON	ON	ON	OFF	OFF
4608 KB	ON	OFF	ON	ON	OFF	ON	ON
4736 KB	ON	OFF	ON	ON	OFF	ON	OFF
4864 KB	ON	OFF	ON	ON	OFF	OFF	ON
4992 KB	ON	OFF	ON	ON	OFF	OFF	OFF
5120 KB	ON	OFF	ON	OFF	ON	ON	ON
5248 KB	ON	OFF	ON	OFF	ON	ON	OFF
5376 KB	ON	OFF	ON	OFF	ON	OFF	ON
5504 KB	ON	OFF	ON	OFF	ON	OFF	OFF
5632 KB	ON	OFF	ON	OFF	OFF	ON	ON
5760 KB	ON	OFF	ON	OFF	OFF	ON	OFF
5888 KB	ON	OFF	ON	OFF	OFF	OFF	ON
6016 KB	ON	OFF	ON	OFF	OFF	OFF	OFF
6144 KB	ON	OFF	OFF	ON	ON	ON	ON
6272 KB	ON	OFF	OFF	ON	ON	ON	OFF
6400 KB	ON	OFF	OFF	ON	ON	OFF	ON
6528 KB	ON	OFF	OFF	ON	ON	OFF	OFF
6656 KB	ON	OFF	OFF	ON	OFF	ON	ON
6784 KB	ON	OFF	OFF	ON	OFF	ON	OFF

Figure A-3. Switch Settings for Non-Paged Memory Already Installed (Continued).

Enhanced Memory Expansion Board Switch Settings

Non-Paged Memory Installed Below	SW1-1	SW1-2	SW1-3	SW1-4	SW1-5	SW1-6	SW1-7
6912 KB	ON	OFF	OFF	ON	OFF	OFF	ON
7040 KB	ON	OFF	OFF	ON	OFF	OFF	OFF
7168 KB	ON	OFF	OFF	OFF	ON	ON	ON
7296 KB	ON	OFF	OFF	OFF	ON	ON	OFF
7424 KB	ON	OFF	OFF	OFF	ON	OFF	ON
7552 KB	ON	OFF	OFF	OFF	ON	OFF	OFF
7680 KB	ON	OFF	OFF	OFF	OFF	ON	ON
7808 KB	ON	OFF	OFF	OFF	OFF	ON	OFF
7936 KB	ON	OFF	OFF	OFF	OFF	OFF	ON
8064 KB	ON	OFF	OFF	OFF	OFF	OFF	OFF
8192 KB	OFF	ON	ON	ON	ON	ON	ON
8320 KB	OFF	ON	ON	ON	ON	ON	OFF
8448 KB	OFF	ON	ON	ON	ON	OFF	ON
8576 KB	OFF	ON	ON	ON	ON	OFF	OFF
8704 KB	OFF	ON	ON	ON	OFF	ON	ON
8832 KB	OFF	ON	ON	ON	OFF	ON	OFF
8960 KB	OFF	ON	ON	ON	OFF	OFF	ON
9088 KB	OFF	ON	ON	ON	OFF	OFF	OFF
9216 KB	OFF	ON	ON	OFF	ON	ON	ON
9344 KB	OFF	ON	ON	OFF	ON	ON	OFF
9472 KB	OFF	ON	ON	OFF	ON	OFF	ON
9600 KB	OFF	ON	ON	OFF	ON	OFF	OFF
9728 KB	OFF	ON	ON	OFF	OFF	ON	ON
9856 KB	OFF	ON	ON	OFF	OFF	ON	OFF
9984 KB	OFF	ON	ON	OFF	OFF	OFF	ON
10112 KB	OFF	ON	ON	OFF	OFF	OFF	OFF
10240 KB	OFF	ON	OFF	ON	ON	ON	ON
10368 KB	OFF	ON	OFF	ON	ON	ON	OFF
10496 KB	OFF	ON	OFF	ON	ON	OFF	ON
10624 KB	OFF	ON	OFF	ON	ON	OFF	OFF
10752 KB	OFF	ON	OFF	ON	OFF	ON	ON
10880 KB	OFF	ON	OFF	ON	OFF	ON	OFF
11008 KB	OFF	ON	OFF	ON	OFF	OFF	ON
11136 KB	OFF	ON	OFF	ON	OFF	OFF	OFF
11264 KB	OFF	ON	OFF	OFF	ON	ON	ON
11392 KB	OFF	ON	OFF	OFF	ON	ON	OFF
11520 KB	OFF	ON	OFF	OFF	ON	OFF	ON
11648 KB	OFF	ON	OFF	OFF	ON	OFF	OFF

Figure A-3. Switch Settings for Non-Paged Memory Already Installed (Continued).

Enhanced Memory Expansion Board Switch Settings

Non-Paged Memory Installed Below	SW1-1	SW1-2	SW1-3	SW1-4	SW1-5	SW1-6	SW1-7
11776 KB	OFF	ON	OFF	OFF	OFF	ON	ON
11904 KB	OFF	ON	OFF	OFF	OFF	ON	OFF
12032 KB	OFF	ON	OFF	OFF	OFF	OFF	ON
12160 KB	OFF	ON	OFF	OFF	OFF	OFF	OFF
12288 KB	OFF	OFF	ON	ON	ON	ON	ON
12416 KB	OFF	OFF	ON	ON	ON	ON	OFF
12544 KB	OFF	OFF	ON	ON	ON	OFF	ON
12672 KB	OFF	OFF	ON	ON	ON	OFF	OFF
12800 KB	OFF	OFF	ON	ON	OFF	ON	ON
12928 KB	OFF	OFF	ON	ON	OFF	ON	OFF
13056 KB	OFF	OFF	ON	ON	OFF	OFF	ON
13184 KB	OFF	OFF	ON	ON	OFF	OFF	OFF
13312 KB	OFF	OFF	ON	OFF	ON	ON	ON
13340 KB	OFF	OFF	ON	OFF	ON	ON	OFF
13568 KB	OFF	OFF	ON	OFF	ON	OFF	ON
13696 KB	OFF	OFF	ON	OFF	ON	OFF	OFF
13824 KB	OFF	OFF	ON	OFF	OFF	ON	ON
13952 KB	OFF	OFF	ON	OFF	OFF	ON	OFF
14080 KB	OFF	OFF	ON	OFF	OFF	OFF	ON
14208 KB	OFF	OFF	ON	OFF	OFF	OFF	OFF
14366 KB	OFF	OFF	OFF	ON	ON	ON	ON
14464 KB	OFF	OFF	OFF	ON	ON	ON	OFF
14592 KB	OFF	OFF	OFF	ON	ON	OFF	ON
14720 KB	OFF	OFF	OFF	ON	ON	OFF	OFF
14848 KB	OFF	OFF	OFF	ON	OFF	ON	ON
14976 KB	OFF	OFF	OFF	ON	OFF	ON	OFF
15104 KB	OFF	OFF	OFF	ON	OFF	OFF	ON
15232 KB	OFF	OFF	OFF	ON	OFF	OFF	OFF
15360 KB	OFF	OFF	OFF	OFF	ON	ON	ON
15488 KB	OFF	OFF	OFF	OFF	ON	ON	OFF
15616 KB	OFF	OFF	OFF	OFF	ON	OFF	ON
15744 KB	OFF	OFF	OFF	OFF	ON	OFF	OFF
15872 KB	OFF	OFF	OFF	OFF	OFF	ON	ON
No non- paged memory on the board	OFF	OFF	OFF	OFF	OFF	ON	OFF
	OFF	OFF	OFF	OFF	OFF	OFF	ON
	OFF	OFF	OFF	OFF	OFF	OFF	OFF

**Figure A-3. Switch Settings for Non-Paged Memory
Already Installed (Continued).**

A.2 Configuring Memory For Use With the PC 6300 vs PC 6300 PLUS

The memory board comes configured for use with the PC 6300 PLUS. To use the expanded memory with the PC 6300, remove the DIP shunt from socket JP1 on the expanded memory board (see Figure A-4). Reinstall the DIP shunt placing pin 9 in pin 1's previous location (upside down).

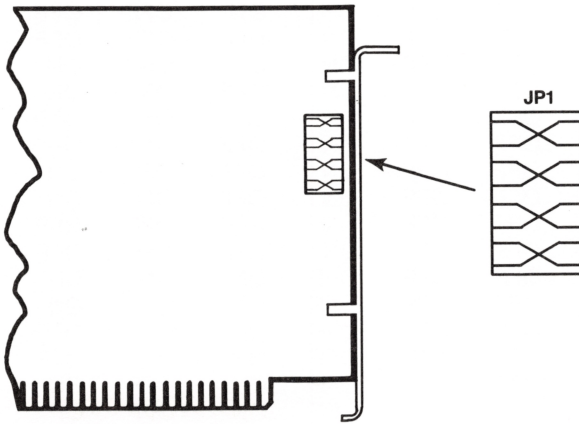

Figure A-4. DIP Shunt JP1 Location.

A.3 Parity Error Checking

DIP switch SW1-8 enables or disables the parity error generation circuitry, as shown in Figure A-5. The default is parity enabled. When the switch is on, parity circuitry is enabled. It is recommended SW1-8 be ON (enabled).

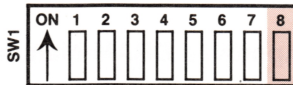

Figure A-5. Parity Error Checking Settings.

A.4 Increasing Memory Capacity on the Memory Board

If your memory board has less than 2 megabytes (MB) of memory (not fully populated), you can plug in 256 kilobytes (KB) Random Access Memory (RAM) chips to increase the board's memory capacity. Figure A-6 shows which memory rows must be populated for each memory size.

Rules for increasing memory:

- For each memory size, all specified rows of chips must be entirely populated with 256-KB chips (150 nanosecond (ns) access time, or faster). If you are using more than one memory board in your system and want to round out conventional memory to 640 KB, use memory from only one board; do not take memory from more than one board to round out conventional memory.

- You must add expanded memory in 512-KB increments — possible memory capacities are 512 KB, 1 MB, 1.5 MB, and 2 MB. This board was designed to run at 150 ns or 120 ns, at 6 Megahertz (MHZ). Table A-1 lists approved manufacturers of 256-KB Dynamic RAM (DRAM) chips you may use to add memory. The AT&T 512-KB RAM chip set (PEC code 37561) is recommended.

Table A-1. Approved DRAM Manufacturers.

256-KB 150 Nanosecond DRAM Chips	
<u>Manufacturer</u>	<u>Manufacturer's Part Number</u>
AT&T	WCM41256PP-15
Fujitso	MB81256-15P
Hitachi	HM50256P-15
Micron Tech	MT1256N-15
Mitsubishi	M5M4256P-15
Motorola	MCM6256P-15
Oki	MSM41256A-15RS
Toshiba	TMM41256P-15

256-KB 120 Nanosecond DRAM Chips	
Fujitsu	MB81256-12P
Hitachi	HM50256P-12
Motorola	MCM6256P-12
NEC	UPD41256C-12
Texas Instruments	TMS4256-12NL
Toshiba	TMM41256P-12

- Whenever you add or remove memory, be sure to readjust the DIP switches if the expanded memory configuration (base I/O address, non-paged memory installed below, or non-paged memory size) changes.

- Memory chips must be installed as indicated in figure A-6.

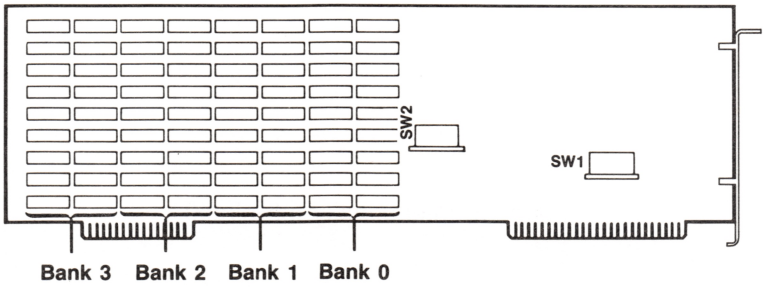

If The Expanded Memory Size is:	These Memory Banks Must be Fully Populated:
512 KB	0
1 MB	0,1
1.5 MB	0,1,2
2 MB	0,1,2,3

Figure A-6. Memory Configuration.

(This page intentionally left blank)

MODIFYING YOUR MS-DOS CONFIG.SYS AND AUTOEXEC.BAT FILES

For most applications, the sample CONFIG.SYS and AUTOEXEC.BAT files provided on your software diskette are ready to use once you change their temporary file names to CONFIG.SYS and AUTOEXEC.BAT. If you already have an AUTOEXEC.BAT or CONFIG.SYS file, you can edit those files to add the necessary text for the expanded memory.

- Section B.1 gives the text of the sample AUTOEXEC.BAT and CONFIG.SYS files included on the software diskette that comes with your expanded memory board.
- Section B.2 is intended for more advanced users, and gives detailed instructions for altering the CONFIG.SYS file.

B.1 Text of Sample Files

The text of the sample files is shown in **bold print**.

Configuration 1A

AUTOEX1A.BAT: **SUPERSPL LPT1:/EXTM**
CONFIG1A.SYS: **DEVICE = AEMM.SYS**
DEVICE = AEX.SYS 128

Configuration 1B

AUTOEX1B.BAT: **SUPERDRV C:/EXTM**
SUPERSPL LPT1:/M = 24
CONFIG1B.SYS: **DEVICE = AEMM.SYS**
DEVICE-AEX.SYS 384

NOTE

SUPERDRV commands are not included for configurations 2A through 2F, and SUPERSPL commands are not included for configurations 2A and 2B. See configurations 1A and 1B for sample SUPERDRV and SUPERSPL commands, or see your *SuperPak User's Manual* for more detailed information.

Configuration 2A

No sample AUTOEXEC.BAT and CONFIG.SYS files for this configuration

Configuration 2B

No sample AUTOEXEC.BAT and CONFIG.SYS files for this configuration.

Configuration 2C

AUTOEX2C.BAT: SUPERSPL LPT1:/EXTM
CONFIG2C.SYS: DEVICE = AEMM.SYS
DEVICE = AEX.SYS 1024
DEVICE = RAMDISK.DEV 576 512 64 /E

Configuration 2D

AUTOEX2D.BAT: SUPERSPL LPT1:/EXTM
CONFIG2D.SYS: DEVICE = AEMM.SYS
DEVICE = AEX.SYS 896
DEVICE = RAMDISK.DEV 832 512 64 /E

Configuration 2E

AUTOEX2E.BAT: SUPERSPL LPT1:/EXTM
CONFIG2E.SYS: DEVICE = AEMM.SYS
DEVICE = AEX.SYS 1664
DEVICE = RAMDISK.DEV 1600 512 64 /E

Configuration 2F

AUTOEX2F.BAT: SUPERSPL LPT1:/EXTM
CONFIG2F.SYS: DEVICE = AEMM.SYS
DEVICE = AEX.SYS 1920
DEVICE = RAMDISK.DEV 1856 512 64 /E

B.2 Modifying Your CONFIG.SYS File

If the sample CONFIG.SYS files do not satisfy your needs, you can modify your CONFIG.SYS file yourself by adding AEMM and/or AEX commands of the following format:

```
DEVICE = AEMM.SYS [/X] [/P] [/S] [/D] [/C] [/I]  
DEVICE = AEX.SYS [nnnn]
```

with the appropriate parameters to your CONFIG.SYS file. This section describes the parameters you can use with each of these commands.

B.2.1 DEVICE = AEMM.SYS Parameters

You can append multiple parameters to the DEVICE = AEMM command. Separate parameters with one blank space. This section describes the following AEMM parameters:

```
DEVICE = AEMM.SYS [/X] [/P] [/S] [/D] [/C] [/I]
```

/X = — Exclude

The /X parameter allows you to exclude certain ranges of memory from AEMM mapping. AEMM should never map into memory space that is already occupied, but you may have an application for which you would like to reserve certain memory ranges.

Format: **/X = nnnn-nnnn**

where *n* is a hexadecimal digit. The first *nnnn* is the starting address of the range, and the second *nnnn* is the ending address.

You can specify multiple ranges as long as you separate each address range with one blank.

Default: None excluded.

Example: **DEVICE = AEMM.SYS /X = C140-CA00 /X = DDDD-DDFF**

Notes: AEMM requires one contiguous 64-kilobyte (KB) segment of memory available for mapping. Do not use the */X* parameter to exclude all contiguous 64-KB segments in the memory area between 640 KB and 1 megabyte (MB).

/PIDS = or /P = — Process IDs

The */P* parameter limits the number of Process IDs that AEMM will allow. *Process IDs* (PIDS) are assigned to each user or application on the system. The *AT&T Enhanced Memory Expansion Board Technical Reference Manual* contains more information on Process IDs.

Format: **/PIDS = n or /P = n** (short form)

where *n* is a decimal number from 2 to 256.

Default: The default value is 32.

Example: **DEVICE = AEMM.SYS /PIDS = 12**

Notes: Increasing the number of Process IDs increases the amount of resident memory used by AEMM.

/START = or /S = — Start

The */S* parameter tells AEMM to put logical page 0 of the mapping window at the specified segment address. This hexadecimal address must be on a 16-KB boundary, and must be within the range C000 through E000.

Format: ***/START =nnnn***

where *n* is a hexadecimal digit.

Default: Determined dynamically by AEMM.

Example: **DEVICE = AEMM.SYS /START =C000**

/DEPTH = or /D = — Depth

The */D* parameter specifies the maximum number of Mapping register contexts per Process ID that AEMM can save. Refer to the *AT&T Enhanced Memory Expansion Board Technical Reference Manual* for a more detailed description of this parameter. Unless you are developing software, the default value should be adequate.

Format: ***/DEPTH = nn***

where *nn* is any decimal number from 1 to 32.

Default: The default value is 5.

Example: **DEVICE = AEMM.SYS /DEPTH = 15**

/CONTEXTS = or /C = — Total Contexts

The */C* parameter specifies the total number of Mapping register contexts that can be saved for all Process IDs combined. Consult the *AT&T Enhanced Memory Expansion Board Technical Reference Manual* for more information about contexts. Unless you are developing software, the default value should be adequate.

Format: ***/CONTEXTS = nnn***

where *n* is a decimal digit.

Default: The value of DEPTH plus the value of PIDS minus one.

Example: ***DEVICE = AEMM.SYS /CONTEXTS = 36***

Notes: The value of CONTEXTS cannot be less than the value of PIDS.

/I = — Base I/O Address

The */I* parameter specifies the base I/O address. The variable xxx is a valid I/O address in the range from 208h to 2F8h. Only these addresses will be tested by the AEMM software to see if the board exists. One or more addresses may be entered by separating them with commas. See Appendix A for all possible base I/O addresses.

Format: ***/I = xxx,xxx,...xxx***

Default: The entire I/O address range.

B.2.2 DEVICE = AEX.SYS Parameters

Format: **DEVICE = AEX.SYS [nnnn]**

where *nnnn* is a decimal number indicating the amount of memory (in KB) allocated for use by AEX.

Default: The default value is 512 (KB).

Example: **DEVICE = AEX.SYS 1024**

Notes: The amount of memory allocated to AEX must be at least as much as the sum of all extended memory used by RAMDISK, SuperDrive, SuperSpool, and any other extended memory application. If you do not express this value as a multiple of 16 KB, it will automatically be rounded up to the next highest multiple.

AEX allows you to use some or all of the expanded memory as extended memory, and can override the expanded memory board switch settings for non-paged memory size.

To reconfigure expanded memory as extended memory, add the appropriate **DEVICE = AEX.SYS** command to your CONFIG.SYS file, then reboot your PC.

The AEX **DEVICE** command must follow the AEMM **DEVICE** command since AEX cannot function without AEMM.

B.2.3 Modifying CONFIG.SYS for RAMDISK

If you intend to use RAMDISK for virtual disk software, be sure to add the appropriate command to your CONFIG.SYS file as described in your *SuperPak User's Manual*. The DEVICE = RAMDISK.DEV statement must follow the AEMM and AEX statements in the CONFIG.SYS file in order for RAMDISK to be able to use extended memory.



