



## The Basic DISK II Pages

### Common Mistakes and Damages to Disk II Controller or DISK II Drives

**Important Warning ! Never dismount or open drives unless they have been disconnected from the computer ( i.e. unplugging the drive from the diskcontroller ) and are without power !**  
 Disobeying may lead to a damaged computer or damaged drive !  
 Only in very few tasks power will be needed and  
 this will be mentioned within the text at the correct place pointing to the needed precautions!

This pages were created as a reaction of the fact that within the Applefritter-site a lot of threads are related to the topic of the Apple-Disk II-system. Due to the age of these diskdrives in a lot of cases they have malfunctions... sometimes just by dirt, sometimes caused by wrong storage and sometimes just as the result of earlier bad treatment like shocks or similar incidents.

So this pages will cover the entire topics of how this drives work, which parts might become damaged and how to maintain this drives by cleaning and adjustment. I will display pictures in detail with markings inserted and comments to explain steps of service to get that drives running again in perfect shape. The order is related to the "toplist" of malfunctions ( i.e. I will treat the topics in the order sorted how often the mistakes happen .... the most common first and the rather rare mistakes thereafter ).

In the preliminary part I have explained the way this drives work to provide the user with some basic knowledge....  
 this should be read too because if you know how the drive works - you will know why you are doing something.  
 - and what the purpose of the task targets for...

this will permit you to perform this tasks better by understanding the task itself and previous pages might contain information that is NOT REPEATED here in this page again !

I hope this pages will become some kind of reference to the topic and save in future a lot of redundant threads and help to keep this drives in good working condition....

This page is a summary of the most common Mistake and damages of the DISK II System  
 - and the reasons how this damages have been performed to the DISK II system.

In specific parts I will announce some kind of percentage within such damages to give a hint  
 - how often such damages occur and  
 - how big chance is that the text covers the trouble you are facing or  
 - how big chance is to solve that kind of trouble.

Please also bear in mind that if you purchase nowadays a DISK II of entire system with controller, that there is quite a chance that some kind of repair has been performed previously and that this kind of repair might have not been solved "professionally" -and that such kind of repairs bear dangers of harming the devices ( specially if cables have been attached wrong way around ! )

At this point it already mentions one of the most common damages that can be performed to the DISK II system - wrong wiring or setting cables wrong way around between disk controller and DISK II system.  
 More than half of all damages are caused by wrong connection of cables !!!

Precaution: if you buy a DISK II from any unknown source ( you don't really know the seller by yourself in person ) then it's strongly recommended to check out the cables by yourself and inspecting if everything is correct !

WHEN opening the DISK II case by removing the 4 screws at the bottom and sliding the hood off you will be able to view at the top of the Drive a PCB called the "analog board":

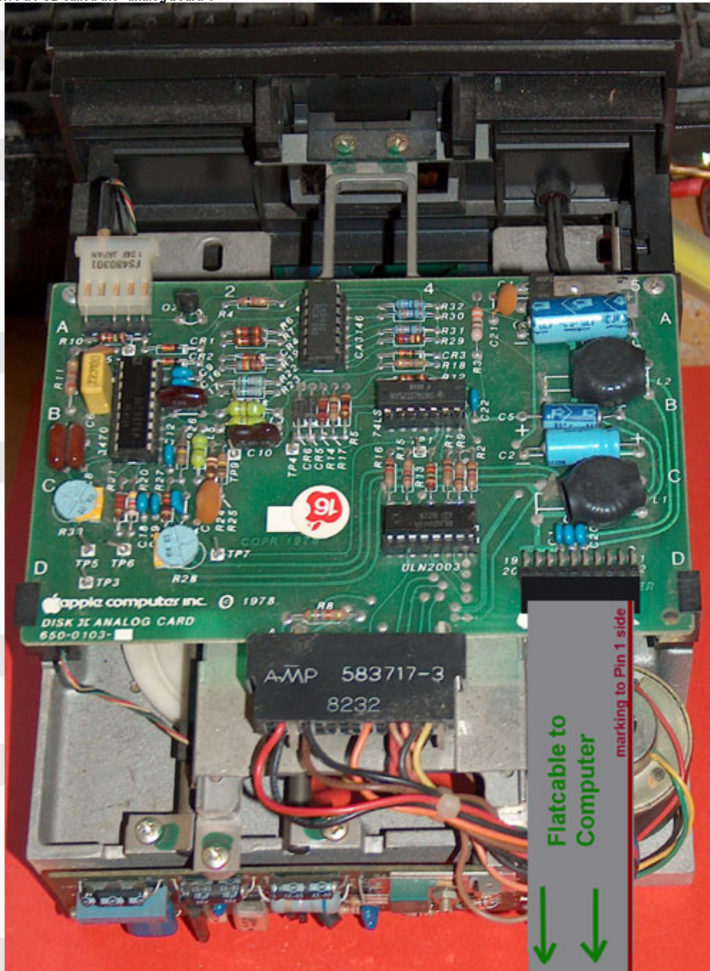

Pay careful attention to the flatribbon cable at the right bottom corner of the picture marked as "Flatcable to Computer" ! recognize at the PCB-Connector where the cable is connected to at the left side of the plug the marking "19" and "20" while at the right side of the plug there is the marking of "1" and below "2" ! Along with the different series of drives the Flatribbon cables have been in the early days so called "rainbow color cables" ( having all the colors also used for indicating numerical values at resistors ) and later being replaced and distributed with grey colored flatribbon cables ( sometimes with attached mounting flaps ). Regardless which cable has been used : You shall mark the side at which the wires of pin "1" and pin "2" run along - and you must mark the cable at BOTH ends ( also that end where you want to plug the cable to the interface ) !!!

In case the plug has an arrow symbol pressed in the plastic ( like indicated in the right picture with red marking arrow ) make sure - that this really indicates at both sides of the flatribbon cable the side of the cable containing pin "1" and "2" ! If the marking is wrong - then at least mark up the plug correct with permanent marker writing or with "heavy duty label" ( not so easy to remove )





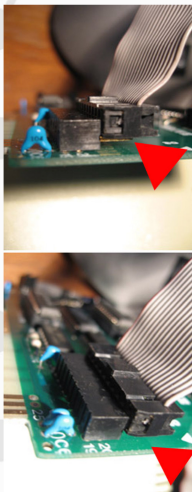

At the left side I display also a very common mistake:  
 Misaligning the plug of the cable at the analog board by leaving the bottom row of pins unused and plugging the lower holes of the plug to the top row of the pins. This is same harming as the mistake by twisting the sides of the cable and plugging pins "1" and "2" of the analog board to pins "19" and "20" at controller side or vice versa!

Both mistakes will cause same result: Because the "analog Board" gets wrong voltages of the supply to the board you will "fry" the circuits on that analog board by making shortcuts or by connecting voltages with wrong polarity!  
 In both cases you must afterwards test and change the IC's at the board - if you are lucky... if not - you might have "fried" parts of the interface or the Apple itself! ( In case you did not immediately shut off Apple again after malfunction.)

Be sure also when connecting cable to the interface to recognize the markings indicating the side related to pin "1" and pin "2"!

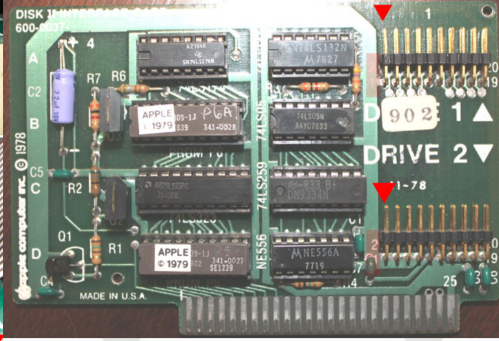

At this place a short intermezzo back to the PCBs of the Disk II:  
 The Analog Board has simple Voltage filtering, the entire Read/Write Logic and  
 - the preamplifier and Amplifier for the Read/Write head and  
 - some simple logic for switches acting as detectors ( like the write protection switch) and  
 - buffering of the track signals that afterwards are sent to the Motor PCB.

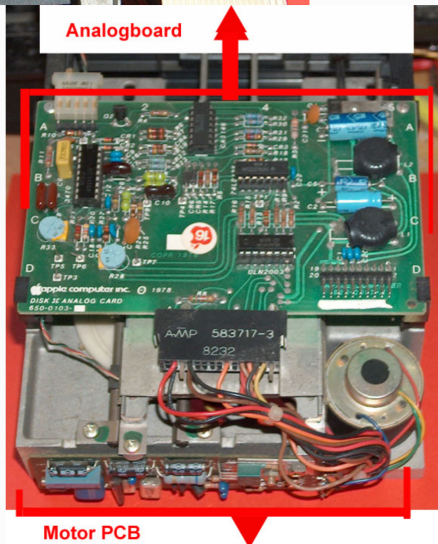
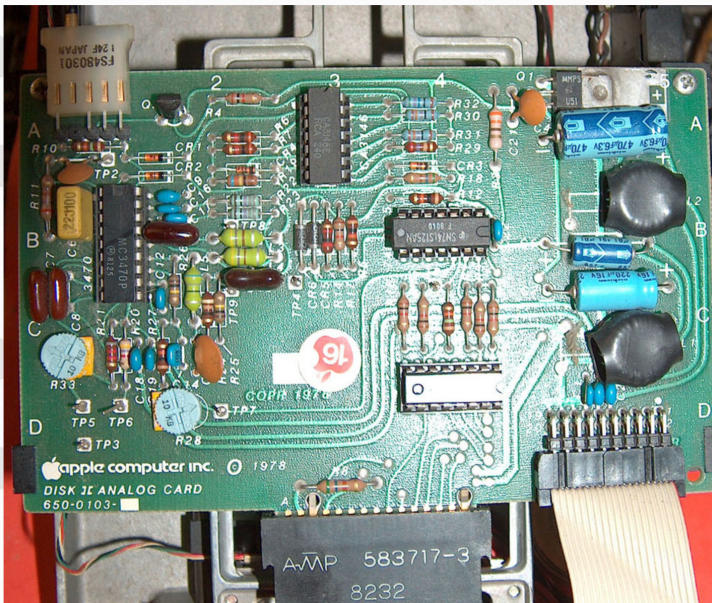

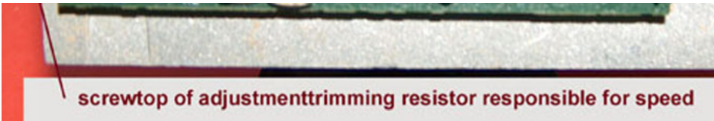

**screwtop of adjustmenttrimming resistor responsible for speed**

- The Motor PCB contains
- the requested powerdriver electronics requested to drive the Positioning Stepper Motor and
- the power regulation electronics demanded from the Disk spinning Motor ( including the speed regulation stage ).

This part of the electronics operates in general with the +12 Volt transferred also in the flatribbon cable from the Apple II Powersource and passing along the Disk II Interface to that Flatribon cable.

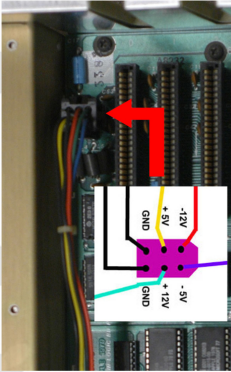

Just besides a remark to diagnostics:  
 If the +12 V has been damaged or is failing this will be indicated by the fact the the Apple also has problems while booting with absent controller and disksystem !  
 This results from the fact that also at the mainboard the RAM chips ( 4116 ) use +12 Volt and in case of bad voltage ( less than 11,5 Volt or more than 12,6 Volt ) while boot reading from ROM will work but relocating the code in memory will fail and the Apple II will end up with "frozen" display.  
 Thats also reason why - during tests for diagnostics - it is also recommended to test again the Apple without the disksystem inserted !  
 If this test fails it's recommended to check the voltages at the voltage input plug from the power supply to the mainboard with a DC Voltage Meter !

If the plugs have been misaligned for any kind of reason - we will now take a closer view to the circuitplan of the Analog board - and the Motor PCB - the parts related to the PCB are marked in the Circuitplan in same color as the PCB Name:

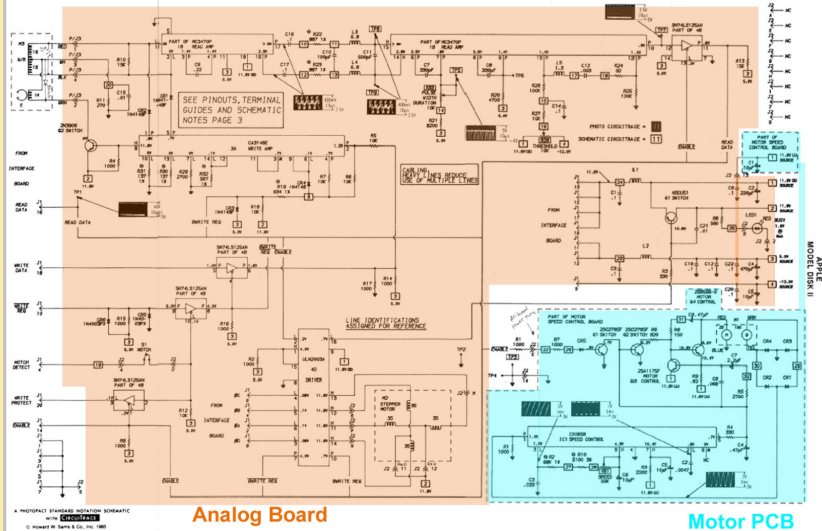

**Analog Board**

**Motor PCB**

In the picture below the Integrated Circuits are marked by color and number and also marked same way at the related PCBs:

## Allocation of ICs at PCB and at circuitplan

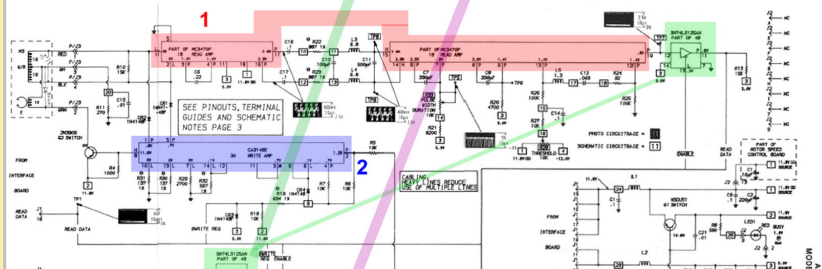
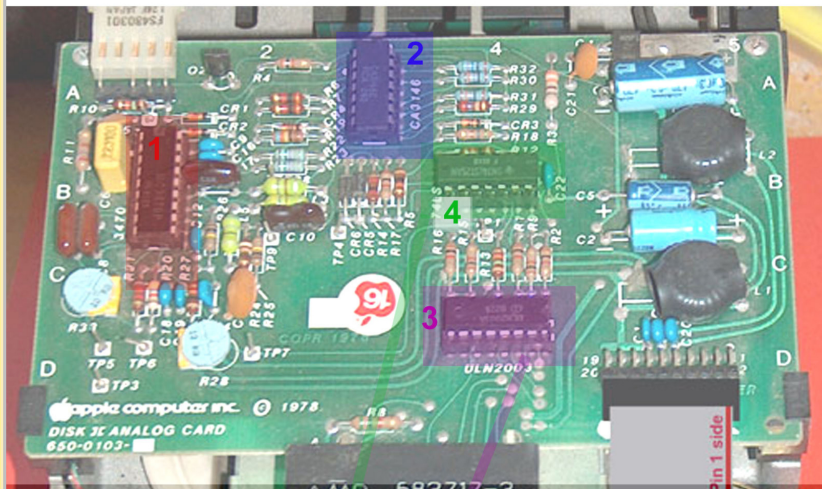



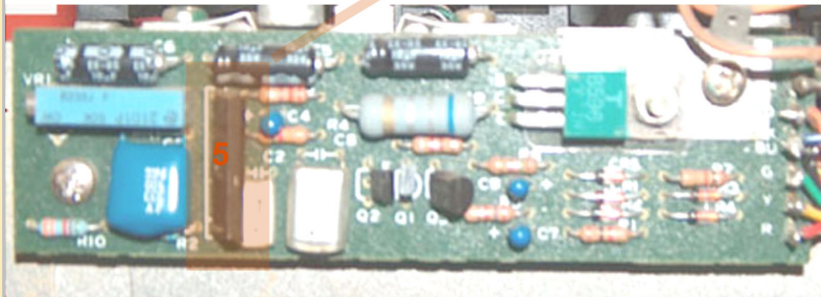
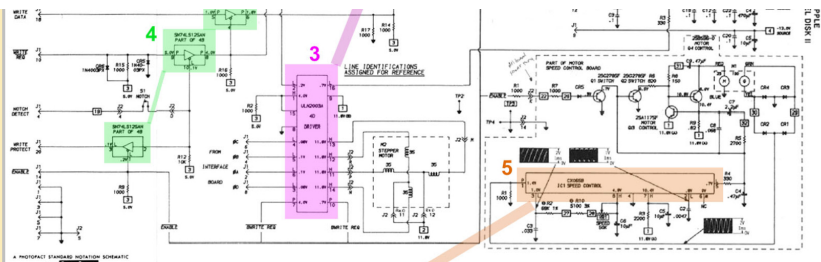

The Hitlist of damaged Circuits is in the order how fast this circuits will be killed at missalignment of the cables and a link to replacement part: 74LS125

<http://www.jameco.com/1/1/25351-74ls125-is-quad-bus-buffer-negative-enable-3-state-dip-14-74ls-series.html>  
the chance that this chip has been killed is about 100% ..... It's the first one that will be killed after about 5 to 10 seconds of power up

Apple II with misaligned plugs  
If this chip is damaged several logic states will be affected - for example also the write protection detection is out of order - instead of reading a disk it might happen that an empty buffer is written to a disk containing information and by that erasing the previous contents - the disk activity LED might probably not work and show that disk in active status. some people at the applefritter forum mentioned that the 74 ACT 125 would not even replace the 74LS125 - but even would be better choice for replacement.....

MC3470P  
<http://www.ebay.com/itm/MC3470P-Original-New-Motorola-Integrated-Circuit-Replaces-NTE3470-400380197238> pt=LH\_DefaultDomain\_0&hash=item5d3884f976  
the chance that this chip has been killed is about 70% ..... It will be killed after about 10 to 20 seconds of power up

Apple II with misaligned plugs  
If this chip is damaged there will not be any read operations possible at the drive !  
If this chip must be replaced the read/write part of the PCB must be readjusted  
- because there is a possible drift at the offset-voltages !

CA3146  
<http://www.ebay.com/itm/RCA-CA3146E-High-Voltage-Transistor-Array-IC-Hard-to-Find-Great-Price-Look/2911611957237>  
the chance that this chip has been killed is still about 70% ..... It will be killed after about 10 to 20 seconds of power up

Apple II with misaligned plugs  
If this chip is dead the erasing function of the diskdrive and the writing condition of the read/write head will be affected and there is danger that all disks will get erased without predictable results.

ULN 2003  
[http://www.jameco.com/webapp/wcs/stores/servlet/Product\\_10001\\_10001\\_1147178\\_-1](http://www.jameco.com/webapp/wcs/stores/servlet/Product_10001_10001_1147178_-1)  
the chance that this chip has been killed is about 25% ..... It will be killed after about 1 to 2 minutes of power up

Apple II with misaligned plugs.  
If this chip is dead this will affect the stepping motor and the recalibration during power on and boot up.  
CX065B  
[http://www.ebay.com/itm/CX065B-Original-New-Sony-Integrated-Circuit-CX-065B-8-759-602-65-400680076292?pt=LH\\_DefaultDomain\\_0&hash=item5d4a64c404](http://www.ebay.com/itm/CX065B-Original-New-Sony-Integrated-Circuit-CX-065B-8-759-602-65-400680076292?pt=LH_DefaultDomain_0&hash=item5d4a64c404)

This chip is nearly never killed because  
before this happens you will have seen smoke coming out of the drive  
while the other 4 ICs would have been fried and cooked !  
If this chip is dead then there will be no correct speed control of the disk spinning motor.

Intermittant added text:

1. the cable from "Analog board" to read/write head is not shielded and it transmits delicate signal... possible solution: changing that very thin cable to a very thin shielded special microphon-cable (with isolated 4 "core" wires !)  
the problem: this special shielded very thin cables are very rare (!) and very extreme expensive (!) hard to get (!) and you have to find one, that is exactly same flexible like the unshielded one formerly used and to be replaced and you have to be very careful while soldering ( the read/write head is very sensible ! )  
short research:  
<http://ex-en.alliedelec.com/search/productdetail.aspx?SKU=70004649#tab=specs>  
or  
[http://www.gotham.ch/en/index.php?section=docsys&cmd=23\\_details&id=15](http://www.gotham.ch/en/index.php?section=docsys&cmd=23_details&id=15)

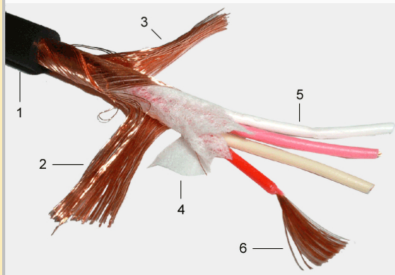

-It is even not sure that this cables will fit the needs....  
- first cable seems not to be flexible enough and second seems to fit ... if it is thin enough  
- it must be previously issued some questions to the seller:  
is the "total"-cable ( referring to the outer diameter of the cable ) really very thin ( less 3mm ) and very extreme flexible ?  
- and shielding of that cable must be connected to Ground of the analog board  
- but none of the four "core"-cables in that cable is connected to ground  
- therfor there must be a fifth connection made to the shielding of that cable isolated from the other four cables  
- and the connection to Ground must be made at the analog board side  
- at the read/write head the shielding must remain without connection staying isolated from the four "core" wires ! - and being covered with shrinkhose for protection against unwanted contacts !.  
2. as explained the signals to the read/write head are very sensible - so at most drives the read/write compensation signal is just adjusted in a "standard general" way ....  
- as far as you tell not to be technician i would give advice to only let experienced technician perform the task: adjusting the read/write compensation at the analog board with control at an oscilloscope as explained in my disk pages - this optimizes the signals from and to the read/write heads cleaning them from unwanted spikes and "dirt impulses" ....  
3. often forgotten: if disk drive is dismounted often the shielding plate is removed to attempt the parts below... and often its not really mounted back properly... it's also good idea to get better electrical connection of the shielding plate to "solid electrical ground" - it's funny that engineers at Apple didn't be aware of the leaking connection between shielding plate and ground... the diskframe is only bad electrical connection:  
solution: solder a flexible wire to the shielding plate and at the other end of the ( rather short ! ) flexible wire mount a pin- connector and add ( +close to the large filtering capacitors at the analog bord at their minus pol ( which is the general ground of the drive ) a pin where that wire connector may be attached to.... this ensures much better operation of the shielding function of the shielding plate....  
Hint to find Ground at the analog board: Pin 1,3,5 and 7 at the connector of the analog board to the plug of the cable to the interface are connected to Ground

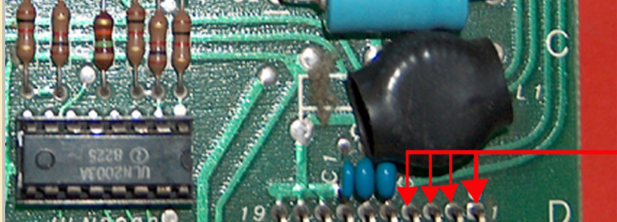

closeup to pins of cablepost connected to Ground



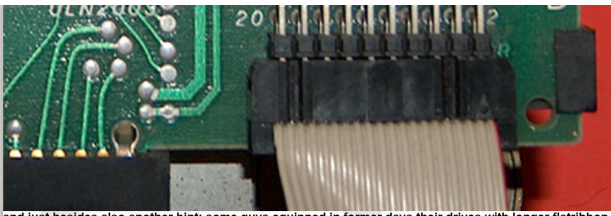

and just besides also another hint: some guys equipped in former days their drives with longer flatribbon cables that's not a good idea...  
 this cable should be really not longer than 2 feet (= 60 cm ).....  
 and even the guys at Apple recognized the problem of unshielded flatribbon cable to the drives ....  
 at least if using the drive roughly and often its better to replace the old unshielded "rainbow" cables with the later used gray flatribbon cables with the attached "mounting plates" - they are shielded and perform their duty much better than the old "rainbow" like cables....  
 ( see pictures of both cables displayed below ! )  
 also to be mentioned here... often in former days users have forgotten while dismantling cable from disk drive to interface from the drive to remount back the inductive core ! That's the cluby ferron ring where the cable has been wrinkled several times through before being attached to the analog board....  
 that inductive core shall be mounted and the cable should make 3 turns through that core and be mounted between the analog board and the fixing clamp at the rearside of the case !

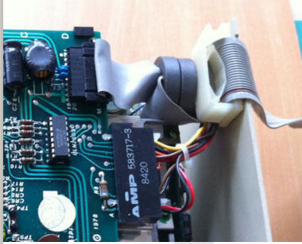

<= This left picture shows the better grey partially shielded cable mounted correct with 2 turns in the inductive core.

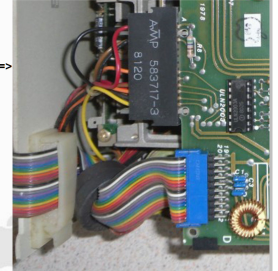

this right picture displays the older => not so good "rainbow" cable and it also displays mistake: the cable runs straight through the inductive core without windings !

all this points will lead to better and more reliable performance of the DISK II drives.

this page will be completed in next days !

<= previous page

<== first page of DISK II Documentation



download this page as PDF-file

continue to previous page about speedadjustment of the drive

continue to previous page about calibrating the track zero

continue to previous page about advanced adjustment of the offset of the electrical Read/Write-Head compensation cycle

common mistakes at the Disk ][ drive and the controller making a homebrew replacement of the DuoDisk Cable

due to european laws and german court decision:

I hereby declare no responsibility to any "deep links" resulting from the links in this page. I have no influence to the pages linked hereby in this page and the contents in those pages. I therefor can't take any kind of responsibility to contents in the pages, where these links direct the readers browser to nor to the contents resulting from following up links from those pages. The reference to contents by this links is dependent ro the status of the date when the links have been set ( April 2013 ) and it might occur that references and contents may change by the fact that domains may have been discontinued from their former owners. In such cases i can't take any kind of responsibility to the changed contents. this is specially valid to banners, advertisements or merchandising links in the targeted pages.

[Back to Indexpage](#)

[page back](#)

[Page forward](#)



published by SpeedyG since 2005 - nonprofit educational site