

LCD Digital Camera

# ***QV-3000EX***

User's Guide

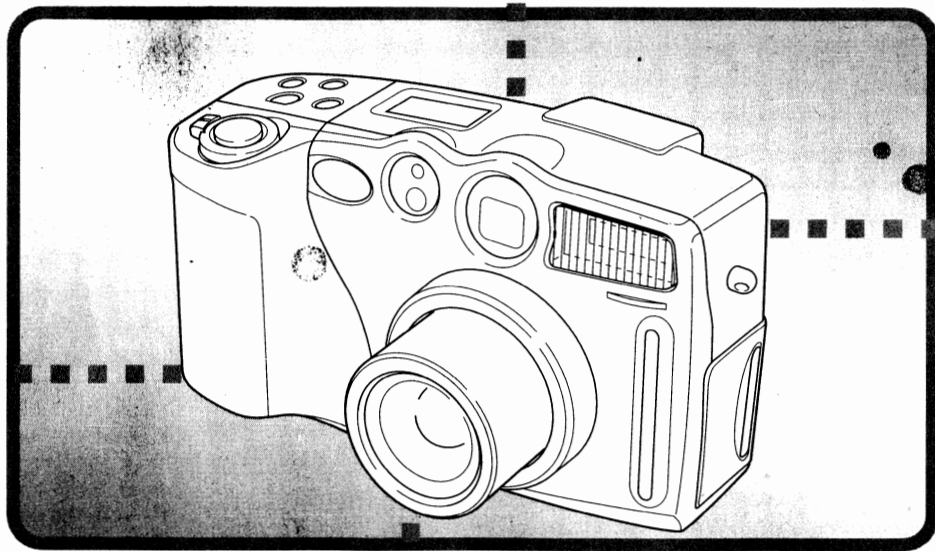

If you need help with  
your camera, please  
call: 1(800)435-7732

**CASIO**

# QUICK REFERENCE

The section provides a general outline of operational procedures.

## Loading Batteries (page 38)

1

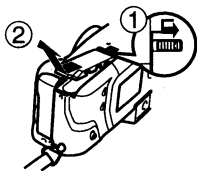

On the bottom of the camera, slide the battery compartment cover lock towards the back of the camera (①) to unlock the cover.

Pressing down on the battery compartment cover, slide it towards the side of the camera to release it, and then swing the cover up to open it (②).

2

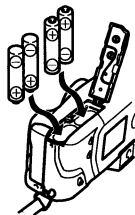

Load the batteries so their plus (+) and minus (-) ends are facing as shown in the illustration.

3

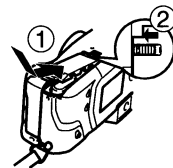

Swing the battery compartment cover closed and then slide it towards the center of the camera to secure it in place (①).

Slide the battery compartment cover lock towards the front of the camera to lock the cover (②).

# QUICK REFERENCE

## Loading a Memory Card (page 33)

1

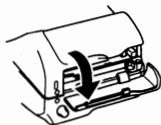

Open the memory card slot cover.

2

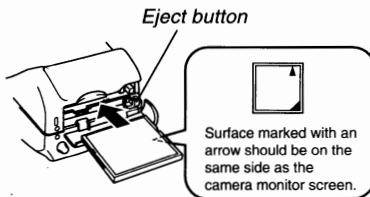

Insert a memory card into the camera so the arrow on the front of the card is on the same side as the camera's monitor screen. Gently but firmly press the card so it enters the slot as far as it will go.

- If the memory card eject button is extended, press it back down before inserting the memory card.

3



Close the memory card slot cover.

# QUICK REFERENCE

## Setting the Current Date and Time (page 45)

- Be sure to use the procedure on page 45 to set the time and date before using the camera for the first time.
- File name assignment and date and time stamping will not be performed correctly if the time and date are wrong.



# QUICK REFERENCE

## Recording Images (page 47)

**3**

After confirming that the Auto Focus operation is complete (the operation lamp lights green), press the shutter button.

**2**

After composing the image on the monitor screen, press the shutter button about half way and hold it there.

- The camera's Auto Focus feature automatically focuses the image.

**1**

Align the POWER/Function Switch with REC.

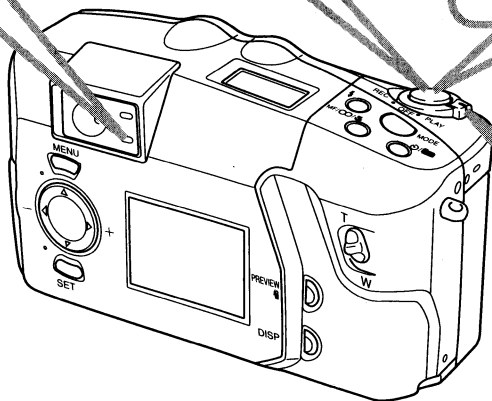

Use the Diopter Dial to adjust the view through the viewfinder to suit your particular eyesight. (page 51)

# QUICK REFERENCE

## Playing Back Images (page 78)

**2**

Use [▶] and [◀] to scroll through the images stored in camera memory.

**1**

Align the POWER/Function Switch with PLAY.

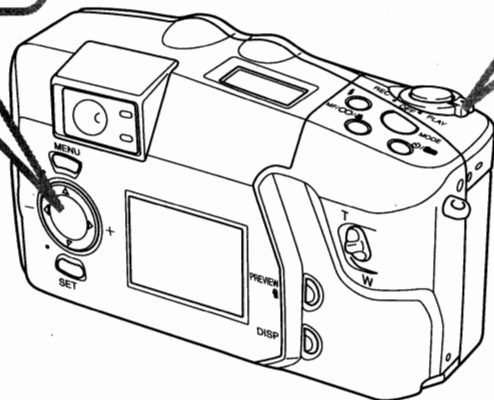

# QUICK REFERENCE

## Deleting Images (page 91)

**2**

Use [▶] and [◀] to select the image you want to delete.

**1**

Align the POWER/Function Switch with PLAY.

**3**

Press the PREVIEW/📷 button.

**5**

Press [▼] to select "Yes" and then press SET button.

**4**

Double check to make sure that you really want to delete the image you selected.

- Press MENU to exit the image delete operation.

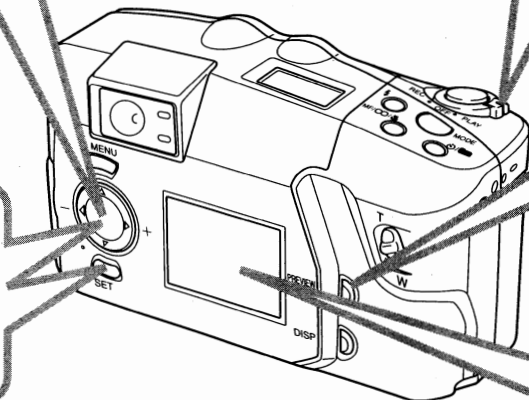

# CONTENTS

## INTRODUCTION

Congratulations upon your selection of the QV-3000EX LCD Digital Camera.  
To get the most out of the QV-3000EX, be sure to carefully read this manual and follow the instructions contained in it.

## 2 QUICK REFERENCE

## 11 FEATURES

## 16 PRECAUTIONS

## 20 UNPACKING

Using the Lens Cap .....	21
Attaching the Neck Strap .....	21
Adjusting the Length of the Neck Strap .....	22
Using the Soft Case .....	22

## 23 GENERAL GUIDE

Lens .....	23
Top and Display .....	24
Side .....	25
Bottom .....	25

## 28 MONITOR SCREEN

REC Mode .....	28
Indicator display .....	30
PLAY Mode .....	30
Menu Screens .....	31

## 33 MEMORY CARDS

Inserting a Memory Card into the Camera .....	33
Removing a Memory Card from the Camera .....	34
Formatting a Memory Card .....	35

## 38 POWER SUPPLY

Loading Batteries .....	38
Using AC Power .....	42
Power Save Settings .....	43

## 45 SETTING THE CURRENT DATE AND TIME

Setting the Date and Time .....	45
Selecting the Date Format .....	46

## 47 RECORDING

Turning Camera Power On and Off .....	47
Using the Shutter Button .....	47
Basic Recording Operation .....	48
Camera Orientation Detection .....	50
Previewing the Last Image Recorded .....	50
Recording Images under Low Battery Power .....	50
Using the Viewfinder for Recording .....	51
Using Focus Lock .....	52
Using the Flash .....	53
Quality Settings .....	55
Exposure Compensation .....	56

## 58 OTHER RECORDING FUNCTIONS

Using the Continuous Shutter Mode .....	58
Using the Zoom Features .....	59
Manual Focus .....	60
Infinity Mode Recording .....	61
Using the Macro Mode .....	61

Movie Recording .....	62
Panorama Recording .....	64
Night Scene Mode .....	65
Landscape Mode Recording .....	66
Portrait Recording .....	66
Shutter Speed Priority Image Recording .....	67
Aperture Priority Image Recording .....	67
Monochrome and Sepia Recording .....	68
Using the Self-timer .....	69
Performing Manual White Balance .....	70
Specifying Power On Defaults .....	71
Using the REC Menus .....	74

## **78** PLAYBACK

Basic Playback Operation .....	78
Playing Back a Movie .....	79
Panorama Playback .....	80
Using Zoom .....	81
Displaying Nine Images .....	82
Slide Show .....	83
Screen Saver .....	84
Using the PLAY Menus .....	85

## **87** FOLDER TYPES

Memory Card Folder Precautions .....	87
Selecting a Folder for Playback .....	88

## **89** IMAGE PROTECTION

Protecting and Unprotecting a Single Image .....	89
Protecting and Unprotecting Folders .....	90
Protecting and Unprotecting All Images on a Memory Card .....	90

## **91** DELETING IMAGES

Deleting the Currently Selected Image .....	91
Deleting a Single Image .....	92
Deleting All the Images in a Folder .....	93
Deleting All Unprotected Images .....	94

## **95** DPOF

Printing Specific Images .....	95
Printing All Images .....	97

## **98** CONNECTIONS

### **99** CONNECTING TO OTHER EQUIPMENT

Connecting to a Television .....	99
Connecting to a Computer .....	100

### **103** USING CompactFlash CARDS WITH YOUR COMPUTER

Setting Up to Access CompactFlash Card Contents From Your Computer .....	103
Memory Card Data .....	104
Card Browser .....	106

**110 TROUBLESHOOTING****114 MESSAGES****116 SPECIFICATIONS**

- CASIO COMPUTER CO., LTD. assumes no responsibility for any damage or loss resulting from the use of this manual.
- CASIO COMPUTER CO., LTD. assumes no responsibility for any loss or claims by third parties which may arise through the use of the QV-3000EX.
- CASIO COMPUTER CO., LTD. assumes no responsibility for any damage or loss caused by deletion of data as a result of malfunction, repairs, or battery replacement. Be sure to back up all important data on other media to protect against its loss.

- *Windows and Internet Explorer are registered trademarks of Microsoft Corporation.*
- *Macintosh is a registered trademark of Apple Computer, Inc.*
- *CompactFlash™ and  logo are registered trademarks of SanDisk Corporation.*
- *Other company, product and service names used herein may also be trademarks or service marks of others.*
- *The USB driver uses software by Phoenix Technologies Ltd.*  
*Compatibility Software Copyright © 1997*  
*Phoenix Technologies Ltd., All Rights Reserved.*
- *IBM is a registered trademarks of International Business Machines Corporation.*

# FEATURES

## Continuous recording (page 58)

Continuous recording of high-quality images at 0.5-second intervals is just like having a motor drive on the camera.

## DCF Data Storage (page 104)

DCF (Design rule for Camera File system) data storage protocol provides image inter-compatibility between the digital camera and printers.

## Digital Print Order Format (DPOF) (page 95)

Images can be easily printed in the sequence you want using a DPOF compatible printer. DPOF can also be used by professional print services when specifying images to produce prints.

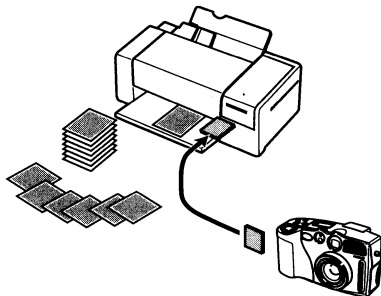

## Simple image management (page 106)

Images are stored on a large-capacity CompactFlash memory card. A new Card Browser feature produces thumbnails of all images on a card quickly and easily.

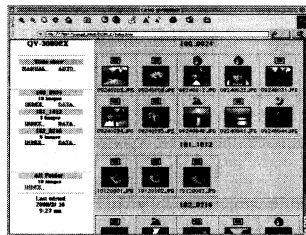

## FEATURES

### Movie and panorama images (pages 62, 64)

A buffer lets you capture images of events that occurred before you pressed the shutter button.

A built-in function lets you combine up to nine images into breathtaking panoramas.

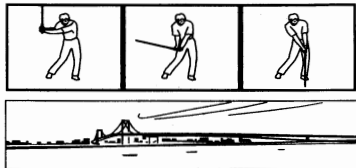

### Easy-to-understand graphic interface (page 28)

All camera operations can be performed on graphic based interactive menu screens. A CASIO high-resolution HAST LCD makes screen images clearer and more colorful than ever before.

### CASIO original metering system

Light metering includes innovative multi-pattern metering.

### Megapixel CCD

Images are recorded by a 3.34-megapixel CCD for amazing resolution and clarity.

Some slight image noise may be caused when using slow shutter speeds.

### Easy connection to other devices (page 98)

USB, DIGITAL, and VIDEO OUT terminals provide easy connection to other devices.

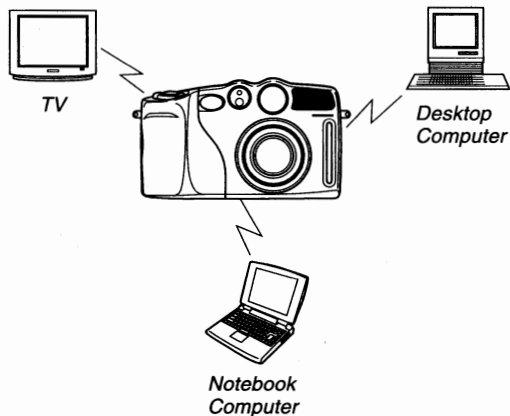



6X zoom is produced using 3X optical zoom together with 2X digital zoom.

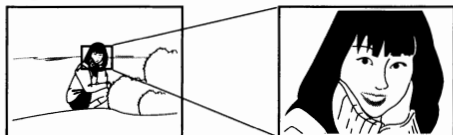

page 59

Macro Feature

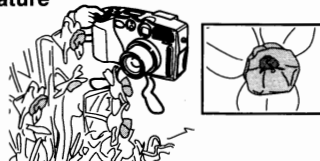

page 61

Landscape Mode

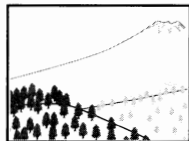

page 66

Portrait Mode



page 66

Night Scene



page 65

Shutter Speed Priority (S Mode)



page 67

Aperture Priority (A Mode)

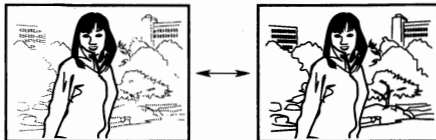

page 67

9-image Screen



page 82

Self-timer



page 69

Slide Show



page 83

Date and Time Stamping



page 45

Display Zoom

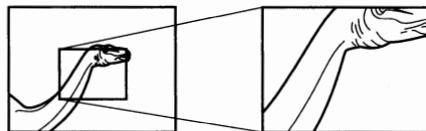

page 81

### Image Protection



page 89

### Camera Orientation Detection

The Photo Loader application automatically rotates the image on your computer screen to compensate for portrait and landscape orientation.

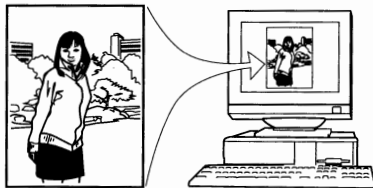

page 50

# PRECAUTIONS

## General Precautions

Be sure to observe the following important precautions whenever using the QV-3000EX.

All references in this manual to “this camera” and “the camera” refer to the CASIO QV-3000EX Digital Camera.

- Never try to take pictures or use the built-in display while operating a motor vehicle or while walking. Doing so creates the danger of serious accident.
  - Never try to open the case of the camera or attempt your own repairs. High-voltage internal components create the risk of electrical shock when exposed. Always leave maintenance and repair work up to authorized CASIO service providers.
  - Never fire the flash in the direction of a person operating a motor vehicle. Doing so can interfere with the driver's vision and create the danger of accident.
  - Never fire the flash while it is too close to the subject's eyes. Intense light from the flash can cause eye damage if it is fired too close to the eyes, especially with young children. When using the flash, the camera should be at least one meter from the eyes of the subject.
  - Keep the camera away from water and other liquids, and never let it get wet. Moisture creates the danger of fire and electrical shock. Never use the camera outdoors in the rain or snow, at the seashore or beach, in the bathroom, etc.
  - Should foreign matter or water ever get into the camera, immediately turn power off, unplug the AC adaptor from the power outlet, and contact your dealer or nearest CASIO service provider. Using the camera under these conditions creates the danger of fire and electrical shock.
- Should you ever notice smoke or a strange odor coming out of the camera, immediately turn power off and unplug the AC adaptor from the power outlet. Using the camera under these conditions creates the danger of fire and electrical shock. After making sure there is no more smoke coming from the camera, take it to your nearest CASIO service provider for repair. Never attempt your own maintenance.
  - At least once a year, unplug the AC adaptor from the power outlet and clean the area around the prongs of the plug. Dust build up around the prongs can create the danger of fire.
  - If the camera's case should ever become cracked due to dropping it or otherwise subjecting it to rough treatment, immediately turn power off, unplug the AC adaptor from the power outlet, and contact your nearest CASIO service provider.
  - Never use the camera inside of an air craft or in any other areas where its use is prohibited. Doing so can result in an accident.
  - Physical damage and malfunction of this camera can cause the image data stored in its memory to be deleted. Be sure to always keep backup copies of data by transferring them to personal computer memory.
  - Never open the battery compartment cover, disconnect the AC adaptor from the camera or unplug it from the wall socket while recording images. Doing so will not only make storage of the current image impossible, it can also corrupt other image data already stored in camera memory.

## Operating conditions

- This camera is designed for use in temperatures ranging from 0°C to 40°C.
- Do not use or keep the camera in the following areas.
  - In areas subject to direct sunlight
  - In areas subject to high humidity or dust
  - Near air conditioners, heaters, or other areas subject to temperature extremes
  - Inside of a closed vehicle, especially one parked in the sun
  - In areas subject to strong vibration

## Condensation

- When you bring the camera indoors on a cold day or otherwise expose it to a sudden change of temperature, there is the possibility that condensation can form on the exterior or on interior components. Condensation can cause malfunction of the camera, so you should avoid exposing it to conditions that might cause condensation.
- To keep condensation from forming, place the camera into a plastic bag before moving it into a location that is much warmer or colder than your current location. Leave it in the plastic bag until the air inside the bag has a chance to reach the same temperature as the new location. If condensation does form, remove the batteries from the camera and leave the battery compartment cover open for a few hours.

## About the camera's backlight...

- The camera is equipped with a fluorescent light source to provide the back lighting for its LCD.
- The normal service life of the backlight is approximately six years, when the camera is used for about two hours a day.
- Should the LCD image appear abnormally dark, take the camera to your dealer or an authorized CASIO service provider to have the light source replaced. Note that you will be charged for this replacement.
- Under very cold conditions, the backlight may require more time than normal to light, or reddish bands may appear in the displayed image. These conditions do not indicate malfunction, and normal operation should return at higher temperatures.

## Monitor Screen

### Recording

- The image shown on the monitor screen during recording is intended for composition purposes only, so its quality does not match that of the image as it is recorded. The image is recorded in accordance with the quality setting made with the procedure under "Quality Settings" on page 55.
- A dimly lit subject can cause static in the displayed image.

### Playback

This camera is designed for high-speed scrolling of images during playback. Because of this, the playback image that initially appears on the monitor screen does not show the full resolution of the image as recorded. When you stop at the image you want, the monitor screen refreshes and shows the image in its full resolution.

## Lens

- Camera performance can be adversely affected by fingerprints or dirt on the lens surface. Never touch the lens surface with your fingers.
- Should the lens become dirty, use a blower to blow off dirt and dust, or a soft, dry cloth to wipe off the lens.
- This camera uses a telescoping type lens, which moves whenever the camera is turned on or off. Make sure nothing is blocking lens movement and never turn power on or off while the camera is laying lens down.
- Never remove batteries or disconnect the AC adaptor while the lens is extended. Doing so can cause the lens to become stuck in the extended position, resulting in camera malfunction.

## Date Setting

No date setting is made before the camera is shipped from the factory. Be sure to use the procedure on page 45 to set the time and date before using the camera for the first time. File name assignment and date and time stamping will not be performed correctly if the time and date are wrong.

**GUIDELINES LAID DOWN BY FCC RULES FOR USE OF THIS UNIT IN THE U.S.A. (not applicable to other areas).**

This device complies with Part 15 of the FCC Rules. Operation is subject to the following two conditions: (1) this device may not cause harmful interference, and (2) this device must accept any interference received, including interference that may cause undesired operation.

**NOTICE**

This equipment has been tested and found to comply with the limits for a Class B peripheral, pursuant to Part 15 of the FCC Rules. These limits are designed to provide reasonable protection against harmful interference in a residential installation. This equipment generates, uses and can radiate radio frequency energy and, if not installed and used in accordance with the instructions, may cause harmful interference to radio communications. However, there is no guarantee that interference will not occur in a particular installation. If this equipment does cause harmful interference to radio or television reception, which can be determined by turning the equipment off and on, the user is encouraged to try to correct the interference by one or more of the following measures:

- Reorient or relocate the receiving antenna.
- Increase the separation between the equipment and receiver.
- Connect the equipment into an outlet on a circuit different from that to which the receiver is connected.
- Consult the dealer or an experienced radio/TV technician for help.

**FCC WARNING**

Changes or modifications not expressly approved by the party responsible for compliance could void the user's authority to operate the equipment.

Properly shielded cables with ferrite core must be used for connection to host computer and/or peripherals in order to meet FCC emission limits.

THE SPECIAL VIDEO CABLE THAT COMES WITH THE CAMERA  
 ---- THE CAMERA TO A VIDEO IN TERMINAL OF A COMPUTER  
 THE SPECIAL CONNECTION CABLE THAT COMES WITH QV-Link SOFTWARE  
 ---- THE CAMERA TO A PROPER TERMINAL OF A COMPUTER

**Declaration of Conformity**

Model Number: QV-3000EX  
 Trade Name: CASIO COMPUTER CO.,LTD.  
 Responsible party: CASIO INC.  
 Address: 570 MT. PLEASANT AVENUE,  
 DOVER,NEW JERSEY 07801  
 Telephone number: 973-361-5400

This device complies with Part 15 of the FCC Rules.

Operation is subject to the following two conditions:

- (1) This device may not cause harmful interference, and
- (2) this device must accept any interference received, including interference that may cause undesired operation.

CASIO COMPUTER CO.,LTD. QV-3000EX



Tested To Comply  
 With FCC Standards

FOR HOME OR OFFICE USE

# UNPACKING

Check to make sure that all of the items shown below are included with your camera. If something is missing, contact your dealer as soon as possible.

*Camera*

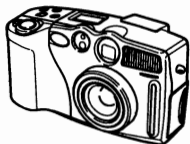

*Soft case*



*Lens cap/cap holder*



*Neck strap*



*Video cable*



*Special USB cable*



*Manual*





## Using the Lens Cap

Be sure to attach the lens cap to the lens whenever you are not using the camera. Be sure to turn off camera power and let the lens retract into the camera before attaching the lens cover.

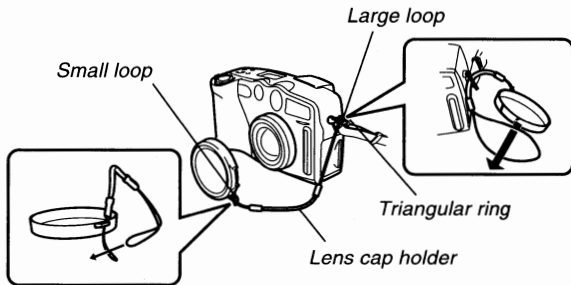

- Attach the lens cap holder to the triangular ring. The cap holder helps to protect against accidental loss of the lens cap.

### ▶▶▶ IMPORTANT! ◀◀◀

Never turn on camera power with the lens cap affixed to the lens.

## Attaching the Neck Strap

Attach the neck strap as shown in the illustration below.

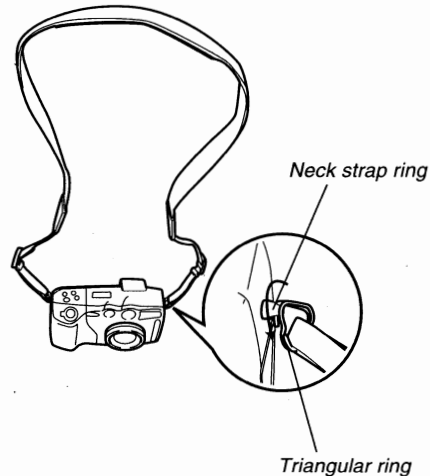

## Adjusting the Length of the Neck Strap

Use the buckle to adjust the length of the neck strap.



### !!! IMPORTANT! !!!

- Be sure to keep the neck strap around your neck when using the camera to protect against accidentally dropping it.
- The supplied neck strap is intended for use with this camera only. Do not use it for any other application.
- Never swing the camera around by the neck strap.
- Allowing the camera to swing freely from your neck can result in damage to the camera due to its bumping against other objects. It also creates the danger of the camera becoming caught in a door or on other objects, resulting in personal injury.
- Keep the camera out of the reach of small children, especially when the neck strap is attached. The neck strap can accidentally wind around the neck of a child and possibly create the risk of strangulation.

## Using the Soft Case

Keep the camera in its soft case to protect it when not in use.

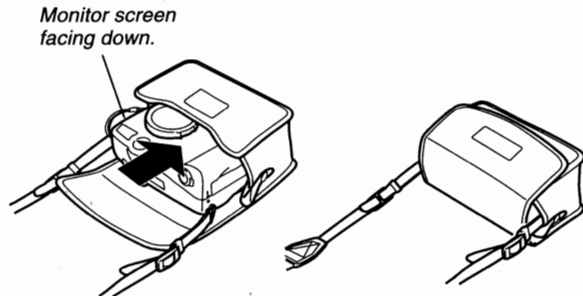

### !!! NOTE !!!

You can leave the soft case hanging from the neck strap when using the camera.

### !!! IMPORTANT! !!!

Never put any other object besides the camera into the soft case.



# GENERAL GUIDE

The following illustrations show the names of each component, button and switch on the camera.

## Lens

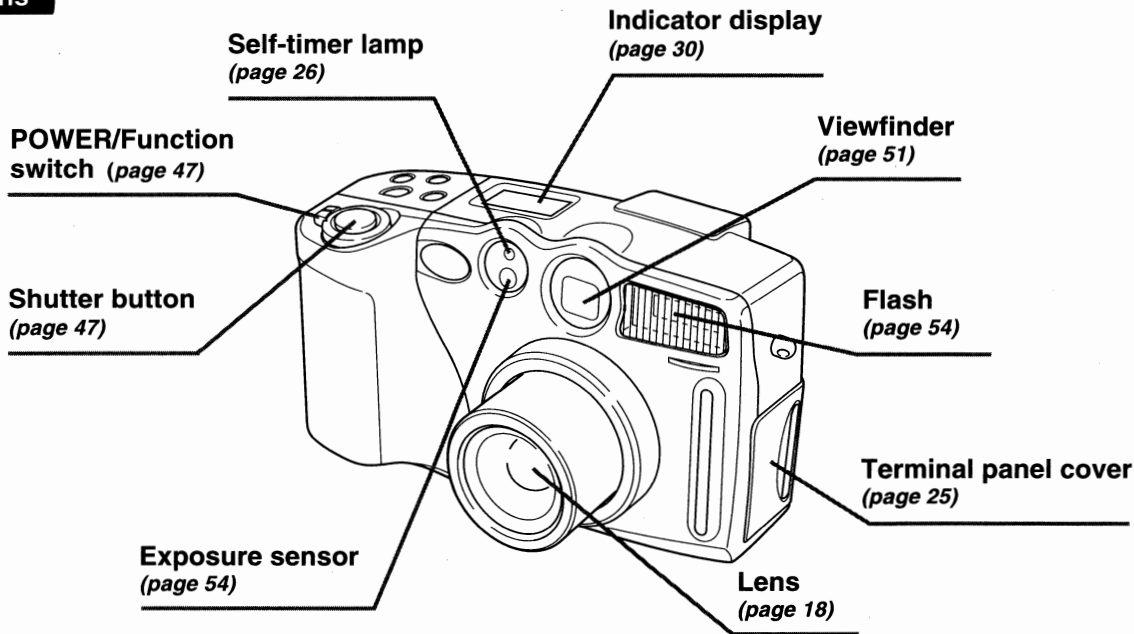

Top and Display

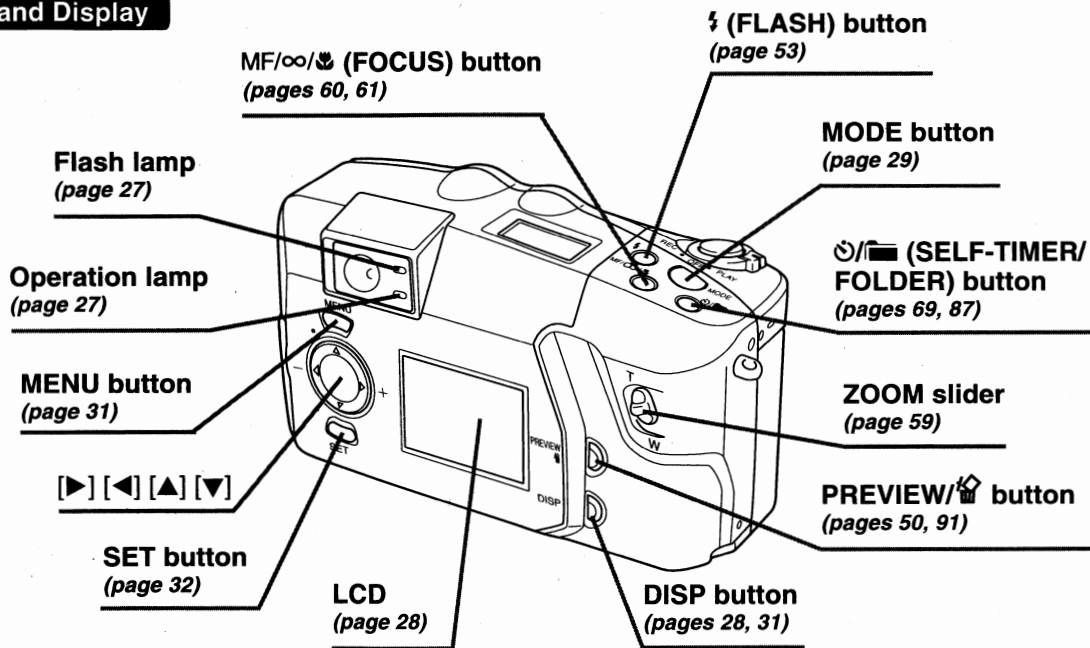

**Side**

**DIGITAL terminal**  
(page 98)

**USB port**  
(page 98)

**AC power terminal**  
(page 42)

**VIDEO OUT terminal**  
(page 98)

**Card access lamp**  
(page 26)

**Memory card slot cover**  
(page 33)

**Diopter dial**  
(page 51)

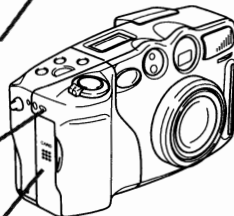
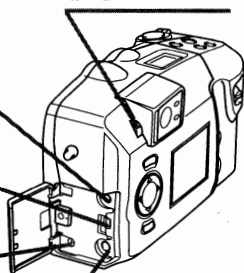

**Bottom**

**Tripod screw hole**

**Battery compartment lock**  
(page 38)

**Battery compartment cover**  
(page 38)

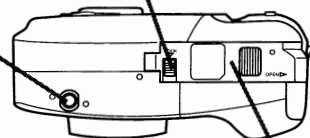

**Opening the Terminal Panel Cover**

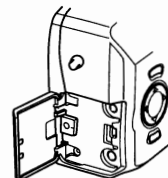
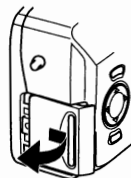

## Card access lamp

The Card access lamp flashes green while the memory card is being accessed.

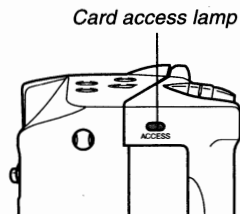

### ▶▶ IMPORTANT! ◀◀

Never open the memory card cover while the card access lamp is flashing.

## Self-timer lamp

The Self-timer lamp flashes when the self-timer is performing a timer operation prior to releasing the shutter.

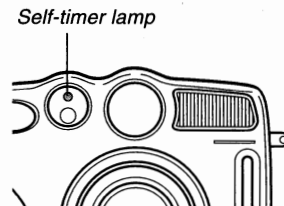

## Operation lamp

The Operation lamp shows the operational status of the camera as described below.

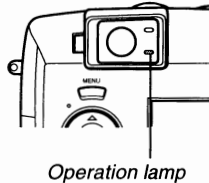

### REC Mode

Lamp Color	Flashing
Green	One of the following operations is in progress: start up, save (multiple), movie recording (PAST) standby

- The camera is ready to record when the lamp is off.

### Partial Shutter Button

Lamp Color	On	Flashing
Green	Auto focus operation complete.	Auto focus operation failed.

## Flash lamp

The Flash lamp also lights and flashes during a record operation as described below.

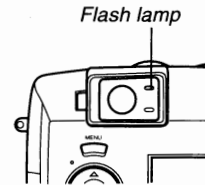

### REC Mode

Lamp Color	Flashing
Amber	Flash is charging.

### Partial Shutter Button

Lamp Color	On
Amber	Ready to fire.

- When the Operation lamp and Flash lamp are both flashing, an error message appears on the monitor screen, regardless of whether the monitor screen is turned on or off.

# MONITOR SCREEN

Pressing DISP causes various indicators to appear on the monitor screen.

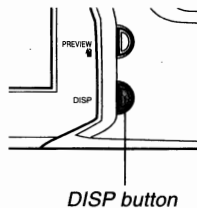

## REC Mode

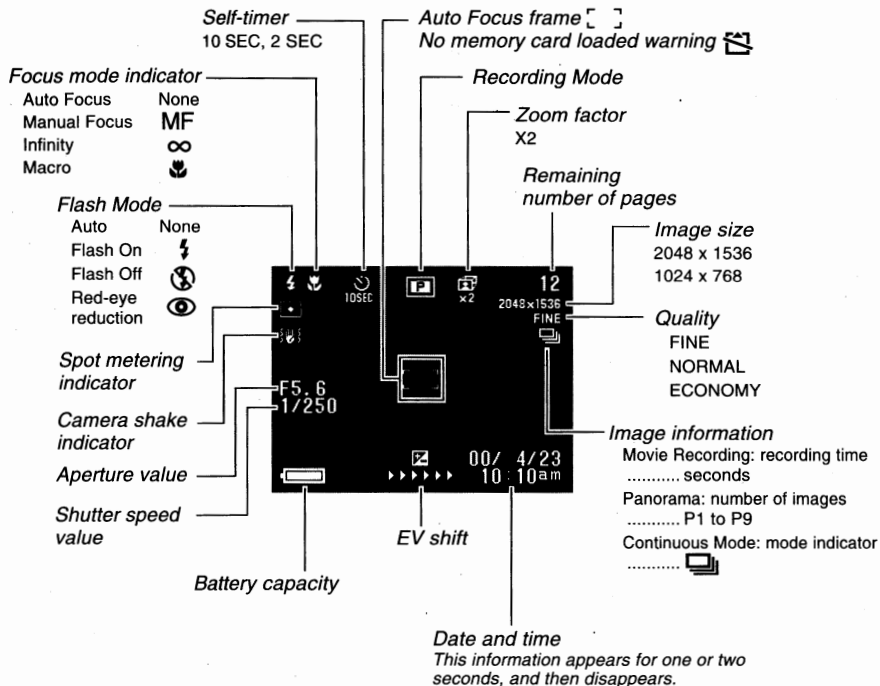



Screen when shutter is pressed half way

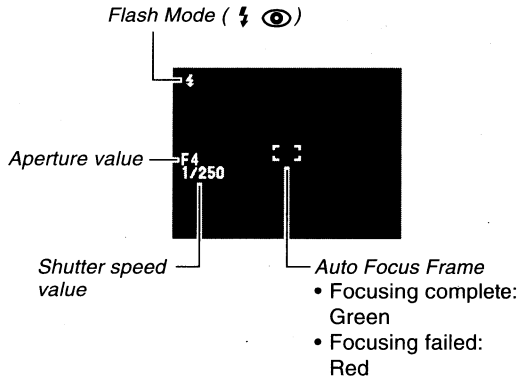

- Flash indicator indicates that the flash will fire (when auto flash is selected).

▶▶▶ IMPORTANT! ◀◀◀

An out of range aperture or shutter speed causes the corresponding monitor screen value to turn orange.

Recording Mode Screen

Pressing the MODE button while in the REC Mode displays the Recording Menu. Use [▶] and [◀] to bring the icon of the function you want to the bottom of the dial (making it the selected function), and then press SET.

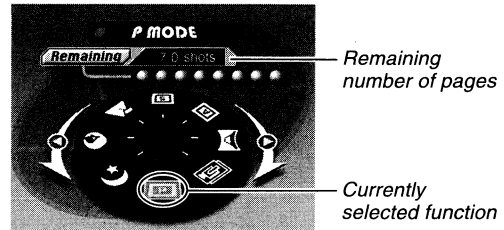

Recording Mode Indicators

	P mode (Normal)		S mode (Shutter Speed priority Auto Mode)
	Movie		Landscape
	Panorama		Portrait
	A mode (Aperture-priority Auto Mode)		Night Scene

## Indicator display

The indicator display located on the top of the camera also shows various camera status indicators during image recording. The indicator display comes in handy especially when the monitor screen is turned off.

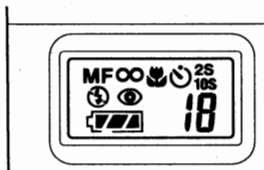

MF	Manual mode indicator		Macro mode indicator
$\infty$	Infinity indicator		Self-timer time settings
	Flash off indicator	number	Remaining number of images/Image number
	Red eye reduction indicator		
	Battery capacity		

## PLAY Mode

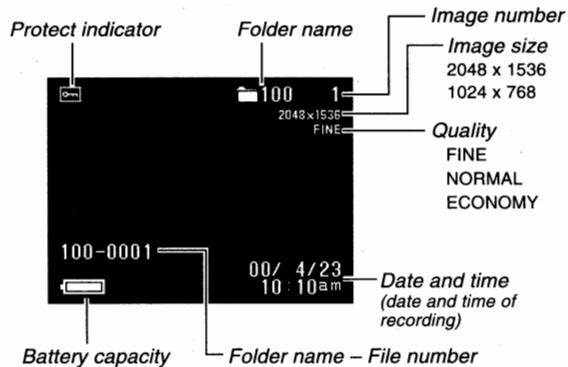

The above indicators appear only when indicator display is turned on with the DISP button.

## Changing the Display Language

Use the following procedure to switch the display language between English and Japanese.

1. Press MENU.
2. Select "Set Up" → "Language".
3. Select the display language you want.

## Menu Screens

Pressing MENU displays the menu screen. The contents of the menu screen depend on whether you are in the PLAY mode or REC mode.

There are two menu formats: basic and advanced. The basic menu displays settings required for basic functions, while the advanced menu includes settings for all functions. Press DISP while a menu screen is on the display to toggle between the basic menu and advanced menu.

In this User's Guide, the basic menu is always used for items that appear on both the basic menu and advanced menu.

- See "Using the REC Menus" on page 74 and "Using the PLAY Menus" on page 85 for more information about menu contents.

### Sample Display: REC Mode

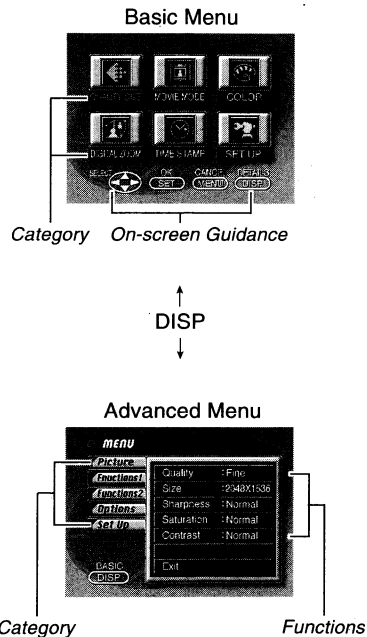

## **Making menu settings**

- 1. While the camera is in the REC or PLAY mode, press MENU.**
- 2. Press DISP to toggle between the basic menu and the advanced menu.**
- 3. Use [▶],[◀],[▼] and [▲] to select the category or function you want, and then press SET.**

[▶] [◀] [▼] [▲]: Item selection

SET : Executes a selection

MENU : Returns to the previous screen or cancels settings.

- Make settings in accordance with the guidance messages that appear on the monitor screen.
- 4. After making the settings you want, select "Exit" and then press SET.**

# MEMORY CARDS

This camera uses a memory card (CompactFlash card or microdrive) for image storage.

## ▶▶ IMPORTANT! ◀◀

- Make sure that the power of the camera is turned off before you insert or remove a memory card.
- When inserting a memory card into the camera, make sure that the card is oriented correctly. Make sure that the correct side of the card is facing up, and that you insert the correct end of the card into the camera.

### Inserting a Memory Card into the Camera

1. Open the memory card slot cover.

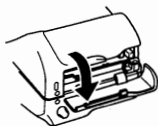

2. Insert a memory card into the camera so the arrow on the front of the card is on the same side as the camera's monitor screen. Gently but firmly press the card so it enters the slot as far as it will go.

- If the Eject button is extended, press it in before sliding the memory card into the slot.

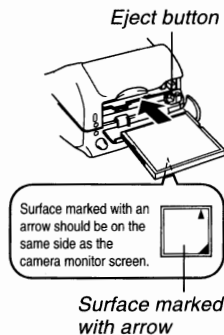

3. Close the memory card slot cover.

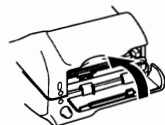

### Removing a Memory Card from the Camera

1. Open the memory card slot cover.

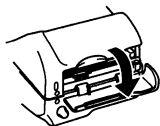

2. Press the eject button so it extends from the camera.

*Eject button*

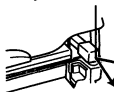

3. Press the eject button once again to eject the card.

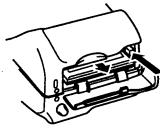

4. Remove the memory card.



5. Close the memory card slot cover.



### ►► IMPORTANT! ◀◀

- Insert only memory cards into the memory card slot. Inserting any other type of card can cause malfunction.
- Should water or any other foreign matter get into the memory card slot, immediately turn off power, unplug the AC adaptor, and contact your original retailer or nearest CASIO Service Provider.
- Never eject the CompactFlash card while the card slot is facing downwards. Doing so creates the danger of the CompactFlash card falling, which can corrupt image data on the card.
- Never remove the memory card from the camera while the operation lamp or card access lamp is flashing. Doing so can cause loss of recorded images or corruption of memory card data.

## Formatting a Memory Card

You can format a memory card to delete all of the data stored on it.

### ))) IMPORTANT! (((

- Formatting a memory card deletes all images on the card, even if some or all of the images are protected (page 89).
- Data deleted by a memory card format operation cannot be recovered! Be sure to carefully check and confirm that you no longer need the data stored in a memory card before formatting it.

1. Press **MENU**.
2. Select **“Set Up”** → **“Format”**.
3. In response to the confirmation message that appears, select **“Yes”** to start formatting the card.

## Memory Card Precautions

- Images cannot be recorded with this camera unless a memory card is installed in it.
- Be sure to use only CASIO brand CompactFlash cards. Proper operation with other memory cards is not guaranteed.
- Static electricity, electrical noise, and other electrical phenomena can cause corruption or even total loss of the data stored on a memory card. Because of this, you should always make backup copies of important images on other media (magnetic optical disk, floppy diskette, computer hard disk, etc.).
- Memory card problems can be corrected by reformatting the memory card (page 114). Reformatting a memory card deletes all images stored on the card, but you can use a computer to copy the images you want to keep to the computer's hard disk before reformatting your card. If you plan to be recording images where you do not have access to a computer, it is a good idea to take along an extra memory card or two just in case you experience an unexpected memory card problem.
- Formatting is recommended for any memory card that you suspect contains corrupted image data (due to a DE-CODE ERROR, strange image colors, malformed images) or newly purchased memory cards.

- Before starting a format operation, load a full set of new batteries (alkaline or lithium) into the camera or connect the AC adaptor to power the camera. Interruption of camera power during the format operation results in improper formatting, making it impossible to use the memory card.

### IBM Microdrive Precautions

Compatibility of the camera with the IBM microdrive has been confirmed by CASIO. However, you should note the following important points whenever using the IBM microdrive.

- Be sure to carefully read all of the documentation that comes with the microdrive before using it.
- Note that the microdrive becomes hot during normal use. Take care when removing it from the camera.
- Take care to avoid strong pressure on the label side of the microdrive when it is removed from the camera. Strong pressure can damage internal components and cause malfunction.
- Never turn off camera power or subject the camera to impact while the card access lamp is flashing. Doing so can cause malfunction of the microdrive.
- The microdrive is a very high precision device. Dropping the camera can result in malfunction of the microdrive, even though the camera is undamaged. Take extra care when handling the camera while the microdrive is installed.

- The microdrive has very large storage capacity. Because of this, certain operations can take a relatively long time to perform.
- The microdrive may not operate properly in areas where barometric pressure is low. Because of this, you should avoid using it at high altitudes.
- A microdrive consumes much more electrical power than a CompactFlash card. Depending on how a microdrive is used, it can greatly reduce battery life. When using alkaline batteries, certain operating conditions and certain battery brands can result in batteries going dead right after you install new ones. Whenever using a microdrive, we recommend that you use rechargeable nickel metal hydride batteries or lithium batteries to power the camera.
- When battery power is low, the amount of time required between shots may become longer. This longer interval is designed to protect the microdrive.

### In case of microdrive malfunction....

- Contact your original microdrive retailer or the contact point noted in the microdrive documentation.
- CASIO does not provide any servicing or maintenance support for the microdrive.
- Note that CASIO assume no responsibility for any data loss you may suffer while using the microdrive.



## Memory Card Folder Precautions

- The camera automatically creates folders (directories) on the memory card and assigns them names based on dates (month and day). Any image you record is automatically stored into the folder that corresponds to the date it is recorded.
- Up to 900 folders can be created on a single card. The following shows a typical folder name.

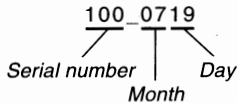

- Up to 250 image files can be stored in each folder. The following shows a typical file name.

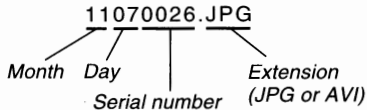

- When you try to save the 251st image to a folder, the camera automatically creates a new folder and store the image there.
- The above maximum numbers of files and folders are absolute maximums. The actual numbers of folders and files may be less due to memory card capacity and the size of each image.
- Panorama images are divided into multiple images and stored on the memory card.
- See "USING CompactFlash CARDS WITH YOUR COMPUTER" on page 103 for information about how files and folders are organized.

# POWER SUPPLY

The camera features a two-way power supply that lets you use either batteries (AA-size alkaline, lithium or Ni-MH) or household AC current.

## Loading Batteries

Be sure that camera power is turned off whenever loading or replacing batteries.

1. On the bottom of the camera, slide the battery compartment cover lock towards the back of the camera (①) to unlock the cover.

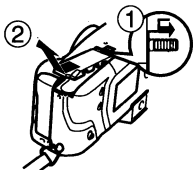

2. Pressing down on the battery compartment cover, slide it towards the side of the camera to release it, and then swing the cover up to open it (②).

3. Load the batteries so their plus (+) and minus (-) ends are facing as shown in the illustration.

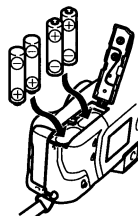

4. Swing the battery compartment cover closed and then slide it towards the center of the camera to secure it in place (①).

5. Slide the battery compartment cover lock towards the front of the camera to lock the cover (②).

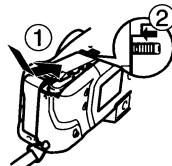

Be sure to use **alkaline, lithium** or **Ni-MH** batteries. Never use manganese batteries (see precautions on the next page).

- Make sure the battery compartment cover is locked securely. Failure to do so can result in the cover opening, creating the danger of personal injury and corruption of image data.

## Standard Battery Life

This camera can be powered by AA-size alkaline, lithium or Ni-MH batteries.

The battery life reference values given below indicate the amount of time at standard temperature (25°C) until power automatically turns off due to battery failure. They do not guarantee that batteries will provide the amount of service indicated. Battery life is reduced by low temperatures and continued use.

Type of Operation	AA-size Alkaline Batteries LR6	AA-size Lithium Batteries FR6	AA-size Ni-MH Batteries NP-H3
Continuous Playback	145 minutes	270 minutes	170 minutes
Continuous Recording	210 shots	900 shots	660 shots

- The above figures are approximations only.
  - The above guidelines are based on the following battery types:  
Alkaline: MX1500 (AA) DURACELL ULTRA  
Lithium: Energizer
  - Battery life varies with brand.
  - Figures are based on continuous recording under the following conditions.  
Flash turned off  
One ZOOM slider switching between T (Telephoto) and W (Wide-angle)
- Recording one image per minute under the above conditions reduces battery life to about one sixth of that noted above. Battery life is greatly affected by how much you use flash, zoom and other functions, and how long you leave power turned on.

### ● Tips for Prolonging Battery Life

- Use the  $\frac{1}{2}$  button to turn off the flash when you are not using it.
- You can also use the power save settings (page 43) to protect against wasting battery power when you forget to turn off the camera.

### ● Alkaline Battery Life

The actual life of alkaline batteries is affected by a variety of factors, including the battery manufacturer, the amount of time the batteries spend in storage before you use them, temperature while you are recording, and photographic conditions. As a rule, we recommend the use of lithium batteries or Ni-MH batteries, which have longer lives than alkaline batteries.

The following examples show how alkaline battery life changes under different conditions.

Example 1: Intermittent use of the camera shortens battery life.

#### Conditions

- Temperature: 25°C
  - Repeat of a cycle of recording of one shot per minute for 10 minutes, followed by one minute of playback, and a nine minutes of power off (power on, full lens extension, half lens contraction, full lens extension, image recording, power off)
  - Flash on
- Approximate Battery Life: 30 minutes (28 shots)

Example 2: Low temperatures shorten battery life.

Conditions

- Temperature: 0°C  
Approximate Battery Life: 7 minutes (7 shots)

### ● About rechargeable batteries

- Use only the nickel-metal hydride batteries (NP-H3) that are available from your dealer as options for this camera. Proper camera operation is not guaranteed when other rechargeable batteries are used.

AC Adaptor Charger (4-battery set) BC-3HA

Nickel-metal hydride batteries (4-battery set)/Quick Charger Set BC-1HB4

Nickel-metal hydride batteries (4-battery set) NP-H3P4

- Be sure to keep all four batteries together as a set at all times, for both charging and powering the camera. Mixing batteries from different sets can shorten overall battery life and cause malfunction of the camera.
- Rechargeable batteries cannot be charged while they are loaded in the camera.

## Battery Handling Precautions

Incorrect use or handling of batteries can cause them to leak or burst and create the danger of serious damage to your camera. Be sure to note the following important precautions to avoid problems with batteries.













CAUTION

- Use only LR6 (AM-3) type alkaline or FR6 type lithium or Ni-MH (nickel-metal hydride) dry cell batteries with this camera. Never mix old batteries with new ones. Doing so can result in bursting or leaking of batteries, creating the danger of fire or personal injury.
- Always make sure that the plus (+) and minus (-) ends of the batteries are facing correctly, as noted by the markings on the camera itself. Improper loading of batteries can result in bursting or leaking of batteries, creating the danger of personal injury or soiling of objects nearby.
- Remove batteries from the camera if you do not plan to use it for more than two weeks.
- Never recharge batteries, never allow direct connection between two ends of a battery, and never try to take batteries apart.
- Do not expose batteries to direct heat or dispose of them by burning. Doing so can create the danger of explosion.
- Never mix batteries of different types.

- Dead batteries are susceptible to leakage, which can cause serious damage to your camera. Remove batteries from the camera as soon as you notice they are dead.
- The batteries that power the camera normally become warm as they discharge.

## Low Battery Indicator

The following shows how the battery capacity indicator on the monitor screen and the indicator display changes as battery power is used. Replace all four batteries as soon as possible after they go dead. If you continue to use the camera while the battery level is  or , camera power will automatically turn off.

Battery Capacity	High ←————→ Low
Monitor Screen	 →  →  → 
Indicator Display	 →  →  → 

## Auto Power Off (Battery Powered Operation Only)

Power automatically turns off whenever you do not perform any camera operation for a specific period. See page 43 for details about how you can specify the Auto Power Off time.

- To restore power, simply turn power back on again.

### »» IMPORTANT! ««

The Auto Power Off function does not operate under the following conditions.

- During Slide Show (page 83)
- While the camera is being operated from a computer or printer connected via a cable or the USB port (page 99).
- Whenever the AC adaptor is connected to the camera.

## Using AC Power

Use the optional AC adaptor (AD-C620) or the AC adaptor charger (BC-3HA) to power the camera.

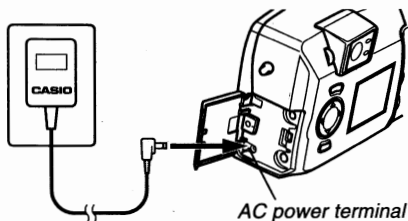

### AC Adaptor precautions

- Never use an electrical outlet whose voltage is outside the rating marked on the AC adaptor. Doing so can create the danger of fire or electrical shock. Use only the optional AC adaptor specified for this camera.
- Should the cord of the AC adaptor become damaged (exposed internal wiring), request a replacement from an authorized CASIO service provider. A damaged AC adaptor cord creates the danger of fire or electrical shock.



CAUTION

- Always be sure to use the AD-C620 AC adaptor only. Using any other AC adaptor can cause damage to the camera not covered by the warranty.
  - When unplugging the AC adaptor from the wall socket, be sure to grasp the adaptor (not the cord).
  - Avoid any undue bending, pulling, and twisting of the AC adaptor's cord, and never try to lengthen the cord by splicing it with other wire.
- Be sure to turn off power before connecting or disconnecting the adaptor.
  - Always turn camera power off before disconnecting the AC adaptor, even if the camera has batteries installed. If you don't, the camera will turn off automatically when you disconnect the AC adaptor. You also run the risk of damaging the camera whenever you disconnect the AC adaptor without first turning power off.
  - The AC adaptor may become warm to the touch after extended periods of use. This is normal and is not cause for alarm.
  - After using the camera, turn it off and unplug the adaptor from the AC outlet.
  - The camera automatically switches over to AC adaptor powered operation whenever the AC adaptor is plugged into the camera.
  - Always use the AC adaptor to power the camera whenever it is connected to a computer.

## Power Save Settings

The settings described below let you specify sleep and auto power off trigger times that help to conserve valuable battery power.

**SLEEP** ..... The monitor screen enters a sleep state if no operation is performed for a specified amount of time in the Record Mode. Pressing any button restores full power. You can specify 30 seconds, 1 minute, or 2 minutes before the sleep state is triggered, or you can turn off this setting entirely.

**AUTO POWER OFF** ..... Auto Power Off turns off camera power if no operation is performed for five minutes in the PLAY Mode, or for two or five minutes in the REC Mode.

- AUTO POWER OFF takes priority when both SLEEP and AUTO POWER OFF are both set for a 2-minute trigger time. This means camera power turns off if no operation is performed after two minutes.

## Setting SLEEP and AUTO POWER OFF Trigger Times

1. Align the POWER/Function Switch with REC.
2. Press MENU.
3. Select “Options” → “Power Save” → “Power Save”.
  - “Options” appears on the advanced menu only.

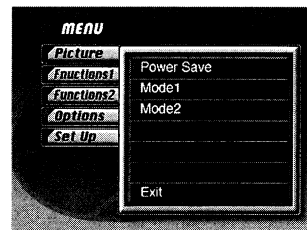

4. Use [▼] and [▲] to select “Sleep” or “Auto Power Off”.
5. Select the trigger time you want to set.
6. When the settings are the way you want them, press SET.
7. Select “Exit”.

## Initializing Power Save Trigger Times

Use the following procedure to return SLEEP and AUTO POWER OFF trigger time settings to their initial factory defaults (SLEEP: 1 minute, AUTO POWER OFF: 2 minutes).

### »» IMPORTANT! ««

Note that performing the following procedure to initialize the power save trigger time settings also initializes mode memory (page 73).

1. Align the POWER/Function Switch with REC.
2. Press MENU.
3. Select "Options" → "Power Save" → "Power Save".
  - "Options" appears on the advanced menu only.
4. Use [▼] or [▲] to select "Sleep" or "Auto Power Off".
5. Select "Restore".
6. Select "Exit".



# SETTING THE CURRENT DATE AND TIME

Use the following procedures to set the current date and time, and to select the date format.

When you record an image, the time and date the image was shot is registered in accordance with data from the camera's built-in clock. You can even use the TIME STAMP function to "stamp" the date and time inside the image.

## ▶▶ IMPORTANT! ◀◀

- The time and date settings are cleared if the camera is left for about 24 hours without battery and AC power being supplied. If this happens, restore power and make new time and date settings before using the camera again.
- A flashing time display indicates that the time and date (clock) settings have been cleared. Use the procedure on this page to make the correct time and date settings.
- If you do not set the camera's built-in clock to the current date and time, all images are recorded with the default date and time, which probably is not your correct current date and time. Be sure to correctly set the clock before you use the camera.

## Setting the Date and Time

1. Press MENU.
2. Select "Set Up" → "Date" → "Adjust".

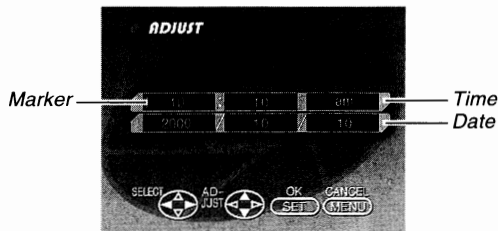

### 3. Set the current date and time.

- Press [▼] and [▲] to change the value or setting at the location of the green marker.
- On the menus, the currently selected item is indicated by the color green. Either the menu item is highlighted in green, or a green marker appears to the left of the menu item to indicate that it is selected.
- Use [▶] and [◀] to move the green marker to the setting you want to change.

## SETTING THE CURRENT DATE AND TIME

4. After making all the settings on the monitor screen, press SET to register them.

### Selecting the Date Format

Example: Feb 1, 2000

You can select any one of the following formats for the above date: 00/2/1, 1/2/00, 2/1/00.

1. Press MENU.
2. Select "Set Up" → "Date" → "Style".



3. Use [▼] and [▲] to select the date format you want, and then press SET.

# RECORDING

## Turning Camera Power On and Off

Rotate the POWER/Function Switch to turn camera power on and off.

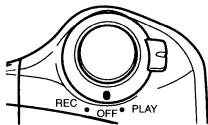

REC : Turns on power and enters the REC Mode.

PLAY : Turns on power and enters the PLAY Mode.

OFF : Turns off power.

### »» IMPORTANT! ««

- Never turn on power while the lens cap is attached to the lens or while the lens is facing downwards.
- To restore camera power after it has been turned off by auto power off, rotate the POWER/Function switch to OFF and then back to REC or PLAY.

## Using the Shutter Button

The following steps describe how to operate the shutter button so that Auto Focus has a chance to focus the image.

### 1. Press the shutter button about half way.

- The Auto Focus feature automatically focuses the image.
- The operation lamp lights green and the Auto Focus Frame in the monitor screen turns green when the Auto Focus operation is complete.

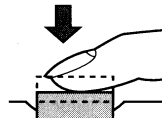

### 2. Press the shutter button as far as it will go to record the image.

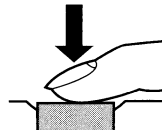

## Basic Recording Operation

The following describes the basic operation for recording images. It describes operation in the P (Program AE) Mode that automatically makes the aperture and shutter speed settings, and lets you record at intervals of about 2 seconds. Note that the interval may become longer if you record more than five consecutive images.

### 1. Align the POWER/Function switch with REC.

- Be sure to remove the lens cap before turning on power.

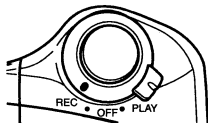

### 2. After composing the image on the monitor screen, press the shutter button about half way and hold it there.

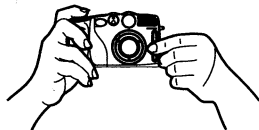

- The monitor screen momentarily goes blank when you press the shutter button half way.
- The camera's Auto Focus feature automatically focuses the image.
- The operation lamp lights green and the Auto Focus Frame in the monitor screen turns green when the Auto Focus operation is complete.
- If you plan to use the viewfinder to compose the image, press DISP several times until the monitor screen turns off.
- Take care to avoid blocking the lens, distance sensor or light sensor with your fingers.
- Press the shutter button carefully, taking care not to move the camera as you do.

### 3. After confirming that the Auto Focus operation is complete (the operation lamp lights green), press the shutter button all the way down to record the image.

- Recorded images are temporarily stored in a buffer, from which they are stored to the memory card installed in the camera. You can continue to store images as long as there is space available in the buffer.

- Pressing the shutter button releases the shutter, even if Auto Focus was unsuccessful and the image is out of focus.
- Use of a tripod is recommended for slow shutter speeds and telephoto shots to avoid blurring of the image due to camera movement.

### ▶▶ IMPORTANT! ◀◀

Auto Focus tends not to work well with the following types of subjects.

- Solid color walls or objects with little contrast
- Strongly backlit objects
- Polished metal or other brightly reflective objects
- Venetian blinds or other horizontally repeating patterns
- Multiple images that are varying distances from the camera
- Subjects in poorly lit areas
- Auto Focus also may not work properly when the camera is unsteady or shaking.

These cases may make it impossible for Auto Focus to focus properly, which is indicated by the operation lamp and the Auto Focus Frame inside the monitor screen remaining red. When this happens switch to the Manual Mode for focusing (page 60). The following are the fixed focusing distances when Auto Focus is unable to focus.

Well-lit Location: 1.5 meters (4.9') minimum

With Flash: Approximately 2 meters (6.6')

Depending on actual conditions, a green operation indicator and Auto Focus Frame do not necessarily guarantee that the image is in focus.

### ▶▶ CAUTION ◀◀

- Never open the battery compartment cover, disconnect the AC adaptor from the camera, or unplug the adaptor from the wall socket while the operation lamp and the card access lamp are flashing green. Doing so will not only make storage of the current image impossible, it can also corrupt other image data already stored in camera memory.
- Fluorescent lighting actually flickers at a frequency that cannot be detected by the human eye. When using the camera indoors under such lighting, you may experience some brightness or color problems with recorded images.

## Camera Orientation Detection

The camera automatically detects whether it is oriented vertically or horizontally when you record an image, and stores the orientation along with the image data.

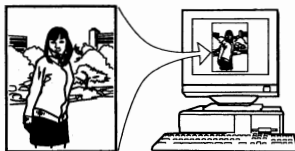



Then when you play back images using the bundled Photo Loader application, they are all automatically oriented correctly on the display.

## Previewing the Last Image Recorded

Use the following procedure to preview the last image recorded, without leaving the REC Mode.

### 1. Hold down the PREVIEW/ button to display the last image recorded.

- The image remains on the monitor screen as long as you keep the PREVIEW/ button depressed.
- You can use the PREVIEW/ button in the Movie Mode, too.
- The PREVIEW/ button does not perform any operation if you press it immediately after turning on camera power or immediately after entering to the REC mode from the PLAY mode.

## Recording Images under Low Battery Power

To protect against unexpected loss of image data, images are recorded one-by-one whenever the battery level is indicated as  or lower. During the save operation, the message "Press **DISP** to cancel save." is on the monitor screen. As long as you do not press DISP, the save operation continues for a few seconds. Be sure to replace all four batteries as soon as possible after this message starts to appear.

Pressing DISP while the "Press **DISP** to cancel save." is on the monitor screen causes the image save operation to be cancelled.

### ▶▶ IMPORTANT! ◀◀

The message described above does not appear while the monitor screen is turned off or while the camera is in the Movie Mode.

## Using the Viewfinder for Recording

The illustrations below show what you see when you look through the viewfinder to compose an image for recording.

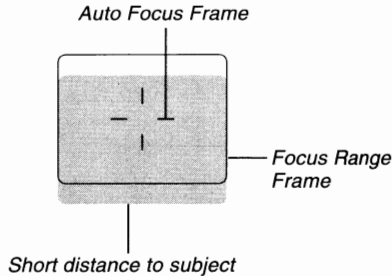

Note that the focus range frame is valid for subjects that are about three meters (9.8') away. A different focus range is used for subjects that are closer or farther away. Because of this, you should use MF/∞/☺ to change to the Manual Mode (MF) or Macro Mode (☺) whenever the distance between the camera and the subject is 30cm or less.

- The monitor screen turns on automatically whenever the camera is in the Macro Mode. Use the monitor screen to compose images in the Macro Mode.

- You can use the Diopter Dial to adjust the image in viewfinder screen to your eyesight.
  - Rotate the diopter dial to adjust the image in the viewfinder to match your eyesight.
- \* Focusing of the viewfinder image is disabled while the camera is turned off or in the PLAY Mode.*

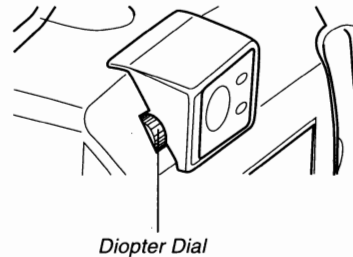

## Using Focus Lock

Normally, Auto Focus automatically focuses on the object that is inside the Auto Focus Frame. Focus lock is a technique that lets you lock the focus on a subject and then move the camera so the Auto Focus Frame is pointed at another subject when you record. This keeps the original subject in focus, even though a different object is within the Auto Focus Frame.

- Locking the focus also locks the exposure setting.

### 1. Align the Auto Focus Frame with the subject you want to lock on and press the shutter button half way down.

- The screen momentarily goes dark when you press the shutter button half way.
- The Auto Focus frame turns green when the image is in focus.



### 2. While keeping the shutter button depressed half way, move the camera and compose the image as you want.

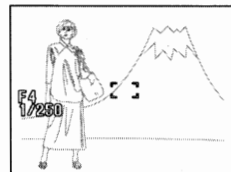





### 3. Press the shutter button all the way down to record the image.







## Using the Flash

You can use the built-in flash unit to provide illumination during recording.

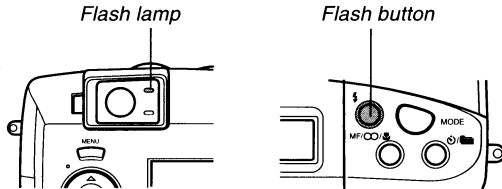
### 1. Press .

- Each press of  cycles through the flash mode in the following sequence: Auto (None) → On () → Off () → Red-eye Reduction (.



Indicator	Flash Mode	Description
None	Auto Flash	Flash is automatically enabled and disabled in accordance with exposure conditions.
	Flash On	Flash is always fired, regardless of exposure conditions.
	Flash Off	Flash is never fired, regardless of exposure conditions.
	Red-eye Reduction	Fires a pre-flash followed by recording with flash, which reduces the chance of red-eye.

- The monitor screen goes blank and the flash lamp flashes amber while the flash unit is charging.

### Camera Shake Indicator

The  (camera shake) indicator appears on the monitor screen when the ZOOM slider is set to T (telephoto) or when a slow shutter speed is being used.

## Flash Indicator

When you press the shutter button half way, the flash icon appears on the monitor screen and the Flash lamp light (amber) to indicate that the flash will fire when the shutter button is pressed the rest of the way down.

### »» IMPORTANT! ««

- Never use the flash in areas where combustible or explosive gas is present. Doing so creates the danger of fire and explosion.
- Never fire the flash in the direction of a person operating a motor vehicle. Doing so can interfere with the driver's vision and create the danger of accident.
- Never fire the flash while it is too close to the subject's eyes. Intense light from the flash can cause eye damage if it is fired too close to the eyes, especially with young children. When using the flash, the camera should be at least one meter from the eyes of the subject.
- Make sure that you do not touch or block the flash or exposure sensor with your fingers. Doing so can soil these components and interfere with correct flash operation.



- Flash should be used for distances within the range of about 0.5 meters (1.6') to 4 meters (13.1') (values with fully open aperture). Flash does not work well outside these ranges.
- Depending on operating conditions (type of batteries being used, temperature, etc.), it may take up to 10 seconds for the flash unit to charge.
- The flash is disabled during movie and continuous recording, which is indicated by the flash icon appearing on the monitor screen.
- The flash unit does not charge when battery power is low. The  indicator appears to warn you that the flash will not fire correctly, which may affect exposure of the image. Replace batteries as soon as possible when this happens.
- Red-eye reduction may not work well when the camera is not pointed directly at the subject or when the subject is far from the camera.
- In the Red-eye Reduction Mode, the flash is fired automatically in accordance with exposure. Because of this, the flash does not fire in a well-lit area.
- White balance is fixed while the flash is being used, so the coloring of the recorded image may be affected by fluorescent lighting or other sources of illumination in the immediate area.

## Quality Settings

The camera has three quality modes: FINE, NORMAL, ECONOMY.

- To determine the number of images that can be stored on a memory card of a different capacity, multiply the capacities in the table below, by the appropriate value.
- The actual number of images that can be stored in memory cannot be specified precisely because the amount of memory required for storage of each image differs according to image contents.

Image size (pixels)	Quality	File size (per image)	Number of images		
			8MB memory card	64MB memory card	512MB Microdrive
2048 x 1536	FINE	1.4 MB/image	5 images	43 images	245 images
	NORMAL	1 MB/image	6 images	60 images	342 images
	ECONOMY	600 KB/image	11 images	99 images	562 images
1024 x 768	FINE	350 KB/image	19 images	167 images	943 images
	NORMAL	250 KB/image	27 images	229 images	1292 images
	ECONOMY	150 KB/image	43 images	365 images	2054 images

- Numbers in parentheses are compressed image file sizes.
- Use the record menus (page 74) to select the quality setting you want.
- Note that the maximum number of images that can be stored in a single folder is 250. Because of this, even if you are using a card that allows storage of more than 250 images, the camera's monitor screen will show its capacity for up to 250 images only. You can store additional images by changing to another folder.
- The number of images that can be recorded may differ when you use Card Browser (page 106).

## Exposure Compensation

This camera features a program AE function that automatically changes shutter speed and aperture in accordance with available light. In addition, you can also manually adjust the exposure to compensate for backlighting, indirect indoor lighting, dark backgrounds, and other special conditions.

- Press DISP to turn on the monitor screen (page 28).

### 1. Use [▶] and [◀] to perform exposure compensation.

- Pressing [▶] or [◀] displays an EV indicator that shows the current exposure compensation setting.
- Pressing [▶] makes the image on the monitor screen brighter. Use it to adjust for dim indoor lighting and backlighting.
- Pressing [◀] makes the image on the monitor screen darker. Use it to adjust for bright sunlight.
- The EV indicator turns red whenever the compensation value is at its limit.

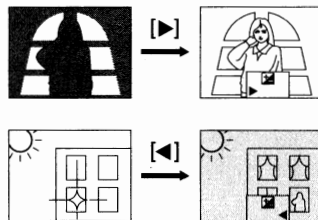

### 2. After adjusting the exposure, press the shutter button to record the image.

#### NOTE

- Exposure compensation is generally expressed in terms of an exposure compensation (EV) value. The exposure compensation value is always set to zero whenever you turn on the camera.
- Each press of [▶] or [◀] changes the exposure compensation value by 1/3EV. A change in either direction is indicated on the monitor screen by arrows pointing left (negative correction) or right (positive correction).
- The normal maximum range for exposure compensation is -2EV to +2EV. Under certain conditions, however, the camera may impose lower maximum values when exposure compensation would result in an image that is too dark or too light.

- The exposure compensation value automatically reverts to zero whenever the shutter button is pressed. You can manually reset the exposure compensation value by using [▶] and [◀] to change the value back to zero, which is indicated when the EV indicator disappears from the monitor. EV value is fixed during panorama recording.
- Changing the exposure compensation (EV) value automatically changes the metering setting to "Center".

# OTHER RECORDING FUNCTIONS

This section describes more advanced recording operations that are also provided by this camera.

- Use the monitor screen for zoom, manual focus, macro, movie, panorama, and multiple exposure.

## Using the Continuous Shutter Mode

The Continuous Shutter Mode lets you record up to three images at intervals of about 0.5 second. It can be used for normal recording, as well as in the P (Program AE), A (Aperture Priority), S (Shutter Speed Priority), Night Scene, Landscape, and Portrait modes.

- 1. Align the POWER/Function Switch with REC.**
- 2. Press MENU.**
- 3. Select “Functions 1” → “Drive Mode” → “Continuous”.**
  - “Functions 1” appears on the advanced menu only.
  - The “” indicator is on the monitor screen while the Continuous Shutter Mode is selected.

## 4. Compose the image and then record it.

- Focus is locked when you record the first image, and this setting is applied to all subsequent images.
- The flash does not fire in the Continuous Shutter Mode.
- You may be able to record only two images in the Continuous Shutter Mode when using the Night Scene Mode, a fixed shutter speed, or a slow shutter speed.
- Do not start a Continuous Shutter Mode operation when the low battery indicator is on the monitor screen.
- Storage of images recorded in the Continuous Shutter Mode to a memory card can take about 14 seconds (for three images).
- Never remove camera batteries, unplug the AC adaptor from the camera, or remove the memory card while images are being saved.

## Using the Zoom Features

The zoom features let you move in closer on subjects that are located far from the camera. You can choose either optical zoom or digital zoom, or even use them in combination to increase the size of the original image by 6 times its original size.

### Using Optical Zoom

Optical zoom enlarges the image by changing the focal distance of the lens. You can increase the size of the image by three times using optical zoom.

#### 1. Align the POWER/Function Switch with REC.

2. Move the ZOOM slider towards T (telephoto) to zoom in on the subject, or W (wide-angle) to zoom out.

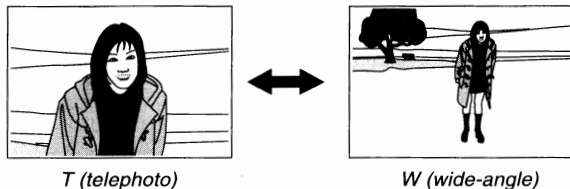
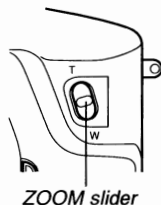

#### 3. Compose the image and then record it.

- Brightness (aperture) is also affected by using optical zoom.
- Use of a tripod is recommended for slow shutter speeds and telephoto shots to avoid blurring of the image due to camera movement.

### Using Digital Zoom

Digital zoom produces a 1024 x 768-pixel image that can double the size of the original image. Using digital zoom and optical zoom in combination can zoom an image to 6X.

See “Using the REC Menus” on page 74 for details on making digital zoom settings.

## Manual Focus

Manual Focus lets you manually adjust the focus of an image.

### 1. Align the POWER/Function Switch with REC.

### 2. Press MF/∞/☝ a number of times until the MF indicator appears on the monitor screen.

- Each press of MF/∞/☝ cycles the focus mode in the following sequence: Auto Focus → Manual Focus (MF) → Infinity (∞) → Macro (☝).

### 3. While “MF” is flashing on the monitor screen, use [◀] and [▶] to focus the image.

- If you do not perform any focus operation for about two seconds, the “MF” indicator stops flashing.
- After “MF” stops flashing, you can use [▶] and [◀] to adjust exposure compensation (EV).
- If “MF” stops flashing before you have a chance to focus, press MF/∞/☝ to make “MF” flash again.
- Pressing MF/∞/☝ while “MF” is flashing changes the focus mode to Infinity.



### 4. Compose the image and then record it.

- The operation lamp and the Auto Focus frame do not appear while manual focus is in use.



## Infinity Mode Recording

Use the Infinity Mode when recording images of scenery or objects that are far away. This mode performs Auto Focus in the vicinity of infinity ( $\infty$ ).

1. Align the POWER/Function Switch with REC.
2. Press MF/ $\infty$ / a number of times until the  $\infty$  indicator appears on the monitor screen.
  - Each press of MF/ $\infty$ / cycles the focus mode in the following sequence: Auto Focus  $\rightarrow$  Manual Focus (MF)  $\rightarrow$  Infinity ( $\infty$ )  $\rightarrow$  Macro (.
3. Compose the image and then record it.





## Using the Macro Mode

Use the Macro Mode for close up shots in the focusing ranges shown below.

Approximate

Focusing Range: 6cm to 30cm (2.4" to 11.8") (1X zoom)  
9cm to 30cm (3.5" to 11.8") (2X zoom)

- The focusing range is the distance from the lens surface to the subject.
- Note that zoom in the range of 1X to 2X only can be used with Macro Mode recording.
- With the macro mode, use the monitor screen to compose the image. Do not use the viewfinder.
- The macro mode can be used aperture settings of F4, F5.6, or F8. A setting of F4 is used automatically with aperture priority recording even if you set an aperture of F2 or F2.3.

1. Align the POWER/Function Switch with REC.
2. Press MF/ $\infty$ / a number of times until the  indicator appears on the monitor screen.
  - Each press of MF/ $\infty$ / cycles the focus mode in the following sequence: Auto Focus  $\rightarrow$  Manual Focus (MF)  $\rightarrow$  Infinity ( $\infty$ )  $\rightarrow$  Macro (.
3. Compose the image and then record it.

### Movie Recording

You can record movies that are approximately 30 seconds long. Movies are recorded in 320 x 240-pixel AVI format. For details, see “Using the REC Menus” on page 74.

There are two types of movie recording: PAST and NORMAL. PAST lets you capture images of events that occurred before you pressed the shutter button while NORMAL records what happens after you press the shutter button.

See “Using the REC Menus” on page 74 for details on how to select the movie length.

- AVI files can be displayed and saved on a computer that is set up to support use of CompactFlash cards. For such a computer, install QuickTime, which comes bundled with the camera.

### NORMAL

1. Align the POWER/Function Switch with REC.
2. Press MODE and then select .

3. Compose the image and then press the shutter button to start recording.

- Auto Focus automatically adjusts in accordance with the movement of the subject.
- See “Playing Back a Movie” on page 79 for details on playing back a movie.
- Movie recording stops automatically 30 seconds after you start the record operation.
- To stop recording before the 30-second period is up, press the shutter button again.

### PAST

1. Align the POWER/Function Switch with REC.
2. Press MENU.
3. Select “Movie Mode” → “Past”.
  - On the advanced menu, select “Functions 2” → “Movie Mode” → “Past”.

**4. Press MODE and then select .****5. Compose the image on the monitor screen and then press the shutter button about half way.**

- Auto Focus automatically adjusts in accordance with the movement of the subject.
- The message “STAND BY” appears on the monitor screen to indicate that the camera’s buffer memory is accumulating image data. This message remains displayed for about 10 seconds.
- After “STAND BY” disappears from the monitor screen, the contents of the buffer memory continues to be updated as long as you keep the shutter button depressed about half way.

**6. Keep the camera pointed at the action you want to record, and press the shutter button all the way down when you want to end recording.**

- Pressing the shutter button after “STAND BY” disappears from the monitor screen records everything that went on in front of the lens during the 10-second period before you pressed the shutter button.

- Pressing the shutter button while “STAND BY” is still on the monitor screen records everything that went on in front of the lens during the period from when you pressed the shutter button half way down and when you pressed it all the way down. In this case, the recording will be less than 10 seconds long.

**))) IMPORTANT! (((**

Flash is disabled during movie recording.

**))) NOTE (((**

## Movie Storage Capacity

Storage Capacity	Approximately 300KB/ second
Recording Time	30 seconds per movie (NORMAL) 10 seconds per movie (PAST)

### Panorama Recording

With panorama recording you record a series of images and then link them to create a single panoramic effect.

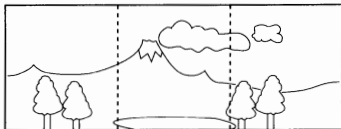

**1. Align the POWER/Function Switch with REC.**

**2. Press MODE and then select .**

**3. Compose the image and then record it.**

- The right edge of the previous image you recorded remains on the monitor screen, so you can align it correctly with the next image.
- From the second image onwards, aim the camera further to the right and overlap the next image with the previous one on the monitor screen.

- Up to nine images can be grouped into a panorama. Press MENU when you want to stop a panorama recording operation.
- Aperture setting and white balance settings are locked when you record the first image of a panorama, and these settings are applied to all subsequent images in that panorama.
- If you want to link more than 9 images into a panorama, upload the images to a computer and use a commercially available computer application to link them.
- See “Panorama Playback” on page 80 for details on playing back panoramas.

## Night Scene Mode

The Night Scene Mode is for recording images in dark areas. When recording images of people on a twilight or night time background, you can use the flash in combination with the Night Scene Mode for slow synchro recording.



1. Align the POWER/Function Switch with REC.
2. Press MODE and then select \*).
3. Compose the image and then record it.

### ))) IMPORTANT! (((

- The shutter speed is quite slow in the Night Scene Mode, so be sure to use a tripod to hold the camera steady.
- Slow shutter speeds used in the Night Scene Mode can cause the recorded image to differ slightly from the image that is actually recorded.
- Auto Focus is difficult in the dark. If you experience problems, use manual focusing (page 60). There may be some blurring of the image if the subject is fast moving.
- The contrast of Night Scene Mode images is not affected by changes made using the REC Menu's Contrast settings (page 75).

### Landscape Mode Recording

The Landscape Mode records images where everything is in clear focus, from the foreground to the background. You can use the Landscape Mode with the ZOOM slider towards W (wide-angle) to record wide-angle images with clear focus from foreground to background.

- Indoors and on cloudy days, images recorded with the Landscape Mode may not differ from those produced by normal recording.

1. Align the POWER/Function Switch with REC.
2. Press MODE and then select .
3. Compose the image and then record it.

### Portrait Recording

In the Portrait Mode, focus is adjusted so the background is slightly blurred, which highlights the subject in the foreground.

- You can further blur the background by moving the ZOOM slider to T (telephoto) while shooting with the Portrait Mode.

1. Align the POWER/Function Switch with REC.
2. Press MODE and then select .
3. Compose the image and then press the shutter button about half way down.
4. After confirming that the subject is in focus, press the shutter button all the way down.

## Shutter Speed Priority Image Recording

You can fix the shutter speed within the range of 2 to 1/1000 second.

1. Align the POWER/Function Switch with REC.
2. Press MODE and then select .
3. Use [▼] and [▲] to select the shutter speed setting you want to use.

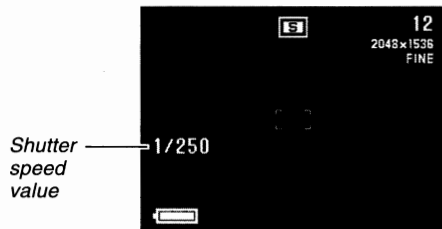

4. Compose the image and then record it.

## Aperture Priority Image Recording

You can fix the aperture within the range of F2 to F8. A larger aperture (indicated by a smaller aperture value) narrows the focus range, while a smaller aperture widens the focus range.

Wide aperture



Decreased aperture



Aperture value	Wide ← → Decreased
	F2, F2.3, F2.8, F4, F5.6, F8

- Adjust the aperture setting to compensate for the relative brightness or darkness of the subject you are recording.

1. Align the POWER/Function Switch with REC.
2. Press MODE and then select .

## OTHER RECORDING FUNCTIONS

- Use [▼] and [▲] to select the aperture setting you want to use.

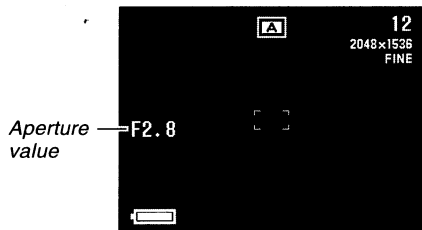

- Compose the image and then record it.

## Monochrome and Sepia Recording

Use the following procedure to record an image in monochrome (black and white) or sepia. Note that you cannot convert an image to color after recording it in monochrome or sepia.

- Align the POWER/Function Switch with REC.
- Press MENU.
- Use [▶], [◀], [▼] and [▲] to select "Color" and then press SET.
  - On the advanced menu, select "Functions 2" → "Color."

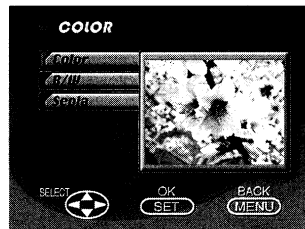



4. Use [▼] and [▲] to select “B/W” or “Sepia” and then press SET.
5. Compose the image and then record it.

### Using the Self-timer





You can use the self-timer for either of the two following recording operations.

**10-second recording ....** Records about 10 seconds after the shutter button is pressed. Use this method when you want to be included in the image that is recorded.

**2-second recording .....** Records about two seconds after the shutter button is pressed. Use this method to avoid camera movement caused when the shutter button is pressed.

**1. Align the POWER/Function Switch with REC.**

**2. Press  / .**

- Each press of  /  cycles the self-timer in the sequence: 10SEC () → 2SEC () → Off.

### 3. Compose the image and then record it.

- The Self-timer Lamp flashes with the passage of each second.
- You can cancel a self-timer operation by pressing the shutter button at any time while the Self-timer Lamp is flashing.

### Performing Manual White Balance

Certain lighting conditions can cause auto white balance to take a very long time or can result in a limitation of the adjustable range (color temperature). If you suspect your current lighting conditions are causing problems, try performing manual white balance. This sets white balance to a level that can be used under any lighting conditions.

The following procedure describes how to perform manual white balance using a white piece of paper. For optimum results, you should use a special reflective plate that should be commercially available from a local camera equipment shop.

1. Align the POWER/Function Switch with REC.
2. Press MENU. If the basic menu appears, press DISP to switch to the advanced menu.
3. Select "Functions 1" → "White Balance" → "Manual".
  - "Functions 1" appears on the advanced menu only.

4. **Keeping the camera pointed at the white sheet of paper, press DISP to make the manual white balance settings.**
  - Pressing SET at this time returns the camera to the white balance setting that was obtained the last time you performed this manual white balance procedure.
5. **The manual white balance procedure stops automatically when it is complete.**
  - If the manual white balance procedure does not end automatically, press SET to interrupt it.
6. **After the camera finishes making the white balance setting, it returns to the screen in step 3 above. Select “Exit” to exit the manual white balance procedure.**

#### ))) NOTE (((

White balance is automatically set to “Daylight” whenever you enter the Night Scene Mode. You can leave this as it is or change it using the above procedure.

### Specifying Power On Defaults

A power on default is one that is automatically used by the camera when you turn it on. You can specify power on defaults for the recording mode, focus, flash, digital zoom, metering, white balance, and flash intensity.

The following tables show the items for which you can specify power on defaults. Note the following rules concerning power on defaults.

- There are two sets of power on defaults, named Mode 1 and Mode 2.
- When “On” is specified for an item, the camera remembers the current setting for that item when you turn off power, and uses the same setting when you turn power back on again.
- When “Off” is specified for an item, the camera always uses its standard power on default, as shown in the “Off” columns in the tables below.

## OTHER RECORDING FUNCTIONS

### Mode 1 (Mode Memory 1)

Setting	Available Options	Mode Memory Status	
		On	Off
Recording Mode	P,  , A, S,  ,  ,	Setting at power off	P Mode
Focus	AF, MF,  ,		AF
Flash	Auto,  ,  ,		Auto
Digital Zoom	Off, On		Off

### Mode 2 (Mode Memory 2)

Setting	Available Options	Mode Memory Status	
		On	Off
Metering	Multi, Center, Spot	Setting at power off	Multi
White Balance	Auto, Daylight, Shade, Tungsten, Fluorescent, Manual		Auto
Flash Intensity	Strong, Normal, Weak		Normal
Sensitivity	+3.0, +2.0, +1.0, Normal		Normal

### Turning power on default settings on and off

1. Align the POWER/Function Switch with REC.
2. Press MENU. If the basic menu appears, press DISP to switch to the advanced menu.
3. Select "Options".
  - "Options" appears on the advanced menu only.
4. Select "Mode 1" or "Mode 2".
5. Select "Mode 1" or "Mode 2".

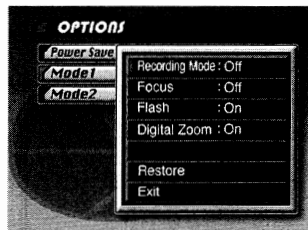

6. Select the item whose setting you want to change.
7. Select "On" or "Off".
  - Repeat steps 6 and 7 for other items if you want.
8. Select "Exit".

## Initializing Power On Defaults and Power Save

Use the following procedure to initialize power on defaults and the power save settings.

### ►► IMPORTANT! ◀◀

Note that performing the following procedure to initialize power on defaults also initializes power save trigger time settings (page 45).

1. Perform steps 1 through 3 under "Turning power on defaults on and off".
2. Select "Power Save", "Mode 1" or "Mode 2".
3. Select "Power Save", "Mode 1" or "Mode 2".
4. Select "Restore".
  - The following table shows the power on default status of each item following the above procedure.
5. Select "Exit".

## OTHER RECORDING FUNCTIONS

Item	Initialized Setting
<b>Power Save</b>	
Sleep	1 min
Auto Power Off	2 min
<b>Mode 1 (Mode Memory 1)</b>	
Recording Mode	Off (P Mode)
Focus	Off (AF)
Flash	On (Last mode select)
Digital Zoom	On (Last mode select)
<b>Mode 2 (Mode Memory 2)</b>	
Metering	Off (Multi)
White Balance	Off (Auto)
Flash Intensity	Off (Normal)
Sensitivity	Off (Normal)

### Using the REC Menus

The REC menus make it easy to control image quality, white balance, and other settings to suit specific conditions and preferences. Each REC menu has two formats: a basic menu and an advanced menu. Press DISP to toggle between the basic menu and advanced menu.

#### NOTE

Recording Mode, Focus, Flash, Digital Zoom, Metering, White Balance, Flash Intensity and Sensitivity settings are retained when camera power is turned off by only if you specify them as power on defaults (page 71). All other settings are retained when you turn off camera power.

### REC Menus

See "Menu Screens" on page 31 for information about how to use menus.

Basic menu items are indicated by **BASIC**.

## OTHER RECORDING FUNCTIONS

### Picture

<b>Quality</b> BASIC	Use this setting to control the quality of the image. Fine / Normal / Economy
<b>Size</b> BASIC	You can specify either of two image sizes in pixels. 2048 x 1536 / 1024 x 768
<b>Sharpness</b>	This setting specifies the sharpness of image outlines. Hard : Sharp outlines Normal Soft : Soft outlines
<b>Saturation</b>	This setting controls the intensity of colors. High : Colors appear deeper. Normal Low : Colors appear lighter.
<b>Contrast</b>	This setting controls the difference between the light areas and dark areas of the image. Contrast is not applied in the Night Scene Mode. High : Larger difference between light and dark. Normal Low : Less difference between light and dark.

### Functions 1

<b>Drive Mode</b>	This setting specifies how the shutter operates. Single : Allows recording of five images at an interval of about 2 seconds. Continuous : Allows recording of sequential images at an interval of about 0.5 second while the shutter button is held down. <ul style="list-style-type: none"><li>• With any of the above settings, the interval may be longer at slow shutter speeds.</li></ul>
<b>Metering</b>	This setting sets the metering method. Multi : Takes readings across the entire image, and provides balanced exposure settings. Center : Takes reading at the center of the image. Spot : Takes reading at a very limited spot at the center of the image. Peripheral lighting does not affect this reading, so exposure is based on the subject alone.



## OTHER RECORDING FUNCTIONS

### White Balance

Use this setting to select the white balance setting that makes the colors of the subject appear most natural.

(Auto / Daylight / Shade / Tungsten /Fluorescent/ Manual)

- Daylight : Outdoors
- Shade : Blue tinted sunlight
- Tungsten : Red tinted incandescent light
- Fluorescent : Green tinted fluorescent light
- Manual : Sets up the camera for recording of a white sheet of paper under currently available light (page 70).

### Flash Intensity

Select the setting for the flash intensity you want to use.

Strong / Normal / Weak

### Sensitivity

Select the approximate sensitivity level.  
+3.0 / +2.0 / +1.0 / Normal

- Higher sensitivity can increase the chance of noise in the image.
- Higher sensitivity can make it difficult to obtain proper focus using Auto Focus. It does not change the minimum brightness required for Auto Focus.
- In the Night Scene Mode, setting sensitivity to +3.0 results in actual sensitivity of about +2.0.
- Use of the flash automatically employs the "Normal" sensitivity setting.
- This setting automatically changes to "Normal" in the Aperture Priority (A) Mode.

## Functions 2

### Movie Mode

**BASIC**

Select the movie mode you want to use.  
Normal / Past

### Digital Zoom

**BASIC**

This item fixes digital zoom at the setting you want.  
Off / On

### Color

**BASIC**

Use this setting to select the color mode you want.  
Color / B/W / Sepia

### Grid

This item turns an on-screen grid on or off. The grid can be used to help align image components vertically and horizontally.  
Off / On

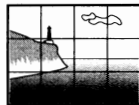

### Time Stamp

**BASIC**

Use this item to turn time stamping on and off, and to control the format of the stamp.  
Off / YMD (Year-Month-Day) / D H:M (Day-Hour-Minutes) / YMD H:M (Year-Month-Day-Hour-Minutes)  
Note that the time stamp cannot be deleted from an image.



## Options

- Power Save** | This item can be used to make power save settings to preserve battery power.  
Sleep (Off / 30sec / 1min / 2min) / Auto Power Off (2min / 5min)
- Mode 1** | Use this item to specify which of the following settings are retained when camera power is turned off.  
Recording Mode / Focus / Flash / Digital Zoom
- Mode 2** | Use this item to specify which of the following settings are retained when camera power is turned off.  
Metering / White Balance / Flash Intensity / Sensitivity

## Set Up

- Card Browser**  
BASIC | Use this item to select the card browser file type.  
Off / Type1 / Type2 / Type3 / Type4
- Format**  
BASIC | Select this item to format a memory card.  
No / Yes
- Date**  
BASIC | Use this item to specify the format of the date that appears in the monitor screen, and to adjust the date setting.  
Style (Year/Month/Day / Day/Month/Year / Month/Day/Year) / Adjust
- Video Out**  
BASIC | This item can be used to specify the format of the video output signal.  
NTSC: Video format in the United States and Japan  
PAL: Video format in Europe and other areas
- Language**  
BASIC | This setting lets you select either English or Japanese as the display language.
- Beep**  
BASIC | Use this item to turn the key input confirmation tone off and on.

# PLAYBACK

The following describes the different techniques that you can use to playback recorded images.

## Basic Playback Operation

The built-in monitor screen of the camera lets you play back recorded images without connecting an external monitor.

### 1. Align the POWER/Function Switch with PLAY.

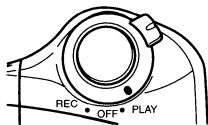

### 2. Use [▶] and [◀] to scroll through the images stored in camera memory.

- Press [▶] to scroll forward and [◀] to scroll back. Holding down either button scrolls at high speed.



### NOTE

The image that initially appears on the monitor screen in the PLAY mode is a preview image. The full of image appears after three seconds. Images copied from another digital camera or a computer may take longer time to appear.

## Playing Back a Movie

Use the following operation to play back a movie that was recorded using the operation under "Movie Recording" on page 62.

1. Align the POWER/Function Switch with **PLAY**.
2. Use [▶] and [◀] to select the movie you want to play back.



3. Press **SET** to start playing back the movie.
  - You can use [▶] (forward) and [◀] (reverse) while playing back a movie to change the playback direction.

- To enlarge the movie image so it fills the entire monitor screen, press **DISP**. Pressing the **DISP** again returns the image to its original small size.
  - Pressing **SET** during movie play pauses playback. Press **SET** again to resume playback.
  - While movie playback is paused, you can use [▶] (forward) and [◀] (reverse) to move frame-by-frame through the movie.
4. After the movie is complete, press **MENU**.

## Panorama Playback

Use the following operation to playback panoramas recorded using the operation under "Panorama Recording" on page 64.

1. Align the POWER/Function Switch with PLAY.
2. Use [▶] and [◀] to select the panorama you want to play back.



3. Press SET to start panorama playback.

- You can change the direction of a panorama that is playing back by pressing [▶] or [◀].

- Pressing DISP changes to a small-image display. Press DISP again to return to the full-screen size.
- Pressing SET during panorama play pauses playback. Press SET again to resume playback.
- While panorama playback is paused, you can use [▶] (forward) and [◀] (reverse) to move frame-by-frame through the panorama.

4. Press MENU to stop panorama playback.

## Using Zoom

The following operation lets you magnify an image to twice and a half its normal size. Note that you can zoom only a single still image.

### ▶▶▶ IMPORTANT! ◀◀◀

Movie and panorama images cannot be zoomed.

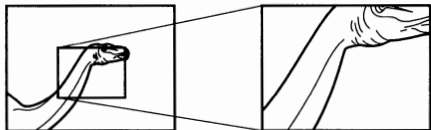

1. Align the POWER/Function Switch with PLAY.
2. Use [▶] and [◀] to select the image you want to zoom.
3. Press MENU.
4. Select "Zoom".
  - On the advanced menu, select "View" → "Zoom".

## 5. Specify the area.

- The portion of the selected area appears on the display at twice and a half its normal size.
- Use [◀] and [▶] to move the area selection frame left and right. Use [▲] and [▼] to move it up and down.

## 6. To return the image to its normal size, press any button besides [▶], [◀], [▼], [▲].



## Displaying Nine Images

The following operation lets you simultaneously view nine images on the same screen. This capability is especially useful when playing back to the screen of a connected TV, and can be used to display a catalog of products, etc.



1. Align the POWER/Function Switch with PLAY.
2. Press MENU.
3. Select "9 Multi".
  - On the advanced menu, select "View" → "9 Multi".
  - The first image of the set is the image that was on the screen when you performed step 2 of this operation. The other images are those that sequentially follow the first one.

## 4. Use [▶] and [◀] to scroll through images stored in memory.

- To view a particular image in normal size, press DISP. This causes the  mark to appear in the upper left corner of the monitor screen. To produce an enlarged view of an image, use [▶] and [◀] to move the  mark to the image you want and then press SET.

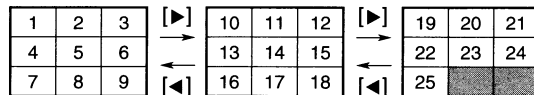

5. After you are finished, press any button besides [▶], [◀], or DISP to return to the normal single-image display.

## Slide Show

Slide Show automatically scrolls through the images stored in memory. You can also specify how much time should be allowed between each image.



### ▶▶▶ IMPORTANT! ◀◀◀

Auto Power Off (page 41) is disabled whenever Slide Show is being used. This means you should not leave Slide Show running when using batteries to power the camera. Doing so can rundown batteries. Be sure to stop Slide Show and turn off the camera after you are finished.

1. Align the POWER/Function Switch with PLAY.
2. Press MENU.
3. Select "Slide Show".
  - On the advanced menu, select "View" → "Slide Show".
4. To stop Slide Show, press any button besides MENU.
  - Pressing MENU while a Slide Show is in progress displays a screen that lets you change the interval within the range of 3 to 30 seconds.
  - Note that all buttons are disabled while an image change is in progress. Wait until an image is stopped on the monitor screen before performing a button operation, or hold down the button until the image stops.
  - Images copied from another digital camera or a computer may take longer time to appear.

## Screen Saver

The screen saver function automatically activates Slide Show (which automatically scrolls through images) whenever you do not perform any operation for about five minutes in the PLAY Mode. This protects the camera's monitor screen and the screen of a connected TV against "burn in" of a static image that is left displayed too long.

### ▶▶▶ IMPORTANT! ◀◀◀

- The screen saver is enabled only when the camera is being powered by its optional AC adaptor. If you do not perform any operation for five minutes under battery power, camera power automatically turns off (Auto Power Off).
- The screen saver displays protected images only. The screen saver is disabled if there are no protected images in memory.
- Photo Loader will not send images between the camera and a personal computer while the screen saver is turned on. Make sure you turn off the screen saver before trying to perform any image transfer operation. Note that the screen saver is turned on when you purchase the camera.

**1. Align the POWER/Function Switch with PLAY.**

**2. Press MENU.**

**3. Select "Tools" → "Screen Saver" → "On".**

- "Tools" appears on the advanced menu only.
- To turn off the screen saver, perform the above procedure and select "Off".
- The screen saver activates if you do not perform any operation for about five minutes in the PLAY Mode.
- Press any key to exit the screen saver.
- When changing between images, the screen saver uses the interval that is specified for Slide Show (page 83).



## Using the PLAY Menu

The PLAY menus provide you with control over the display format and DPOF settings, image delete and save operations, and other settings. Each PLAY menu has two formats: a basic menu and an advanced menu. Press DISP to toggle between the basic menu and advanced menu.

## PLAY Menu

See "Menu Screens" on page 31 for information about how to use menus.

Basic menu items are indicated by **BASIC**.

View	<b>Zoom</b> <b>BASIC</b>	Enlarges the image on the monitor screen.
	<b>9 Multi</b> <b>BASIC</b>	Displays nine images on the monitor screen.
	<b>Slide Show</b> <b>BASIC</b>	Automatically scrolls through the images one-by-one.

Tools	<b>Protect</b>	Use this item to protect images against deletion. Select : Protects a single specific image. Folder : Protects all images in a specific folder. All : Protects all images.
	<b>DPOF</b> <b>BASIC</b>	Use this item to specify images for printing on a DPOF printer. Select : Prints a single specific image. All : Prints a specific number of copies of all images.
	<b>Screen Saver</b>	This item turns the screen save off and on.
Set Up	<b>Card Browser</b> <b>BASIC</b>	Use this item to select the card browser file type. Off/ Type1 / Type2 / Type3 / Type4
	<b>Format</b> <b>BASIC</b>	Select this item to format a memory card.
	<b>Date</b> <b>BASIC</b>	Use this item to specify the format of the date that appears in the monitor screen, and to adjust the date setting. Style(Year/Month/Day / Day/Month/Year / Month/Day/Year) / Adjust

## PLAYBACK

Set Up	<b>Video Out</b> <b>BASIC</b>	This item can be used to specify the format of the video output signal. NTSC : Video format in the United States and Japan PAL : Video format in Europe and other areas
	<b>Language</b> <b>BASIC</b>	This setting lets you select either English or Japanese as the display language.
	<b>Beep</b> <b>BASIC</b>	Use this item to turn the key input confirmation tone off and on.
Delete	<b>Select</b> <b>BASIC</b>	Deletes a single specific image.
	<b>Folder</b> <b>BASIC</b>	Deletes all unprotected images in a specific folder.
	<b>All</b> <b>BASIC</b>	Deletes all unprotected images.

# FOLDER TYPES

## Memory Card Folder Precautions

The camera automatically creates folders (directories) on the memory card and assigns them names based on dates (month and day). Any image you record is automatically stored into the folder that corresponds to the date it is recorded.

- Up to 900 folders can be created on a single card. The following shows a typical folder name.

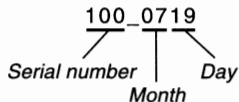

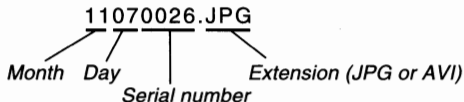

- Up to 250 image files can be stored in each folder. The following shows a typical file name.



- When you try to save the 251st image to a folder, the camera automatically creates a new folder and store the image there.
- The above maximum numbers of files and folders are absolute maximums. The actual numbers of folders and files may be less due to memory card capacity and the size of each image.
- Panorama images are divided into multiple images and stored on the memory card.
- See "USING CompactFlash CARDS WITH YOUR COMPUTER" on page 103 for information about how files and folders are organized.
- If there are more than 250 image files in a folder (due to copying from another digital camera or a computer), only the first 250 (in name sequence) can be played back.

### Selecting a Folder for Playback

1. Align the POWER/Function Switch with PLAY.
2. Press / .
3. Use [▶] and [◀] to select the folder you want to select for playback.

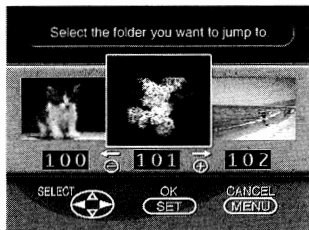

4. Press SET to playback the first image in the folder.

# IMAGE PROTECTION

Use the following operations when you want to protect images against accidental deletion. A protected image cannot be deleted until it is unprotected. You can protect and unprotect a single specific image, all the images in a particular folder, or all images currently on the memory card.

## ▶▶ IMPORTANT! ◀◀

Formatting a memory card (page 35) deletes all images on the card, even if some or all of the images are protected.

### Protecting and Unprotecting a Single Image



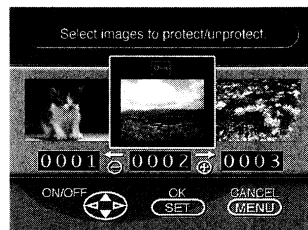

1. Align the POWER/Function Switch with PLAY.
2. Press MENU.
3. Select “Tools” → “Protect” → “Select”.
  - “Tools” appears on the advanced menu only.

#### 4. Select the image you want to protect.





- Selected images are indicated by .
  - Repeat step 4 to select other images if you want.
5. After all the images you want to protect are selected, press SET to protect them.

### Protecting and Unprotecting Folders

1. Align the POWER/Function Switch with PLAY.
2. Press / .
3. Use [▶] and [◀] to select the folder you want to protect.
4. Press SET.
5. Press MENU.
6. Select “Tools” → “Protect” → “Folder”.
  - “Tools” appears on the advanced menu only.
7. Select “Protect” or “Unprotect”.
  - The  indicator in the upper left corner of an image when image information is turned on indicates it is protected.
  - The  indicator does not appear when an image is not protected.

### Protecting and Unprotecting All Images on a Memory Card

1. Perform steps 1 through 2 under “Protecting and Unprotecting a Single Image”.
2. Select “Tools” → “Protect” → “All”.
  - “Tools” appears on the advanced menu only.
3. Select “Protect” or “Unprotect”.
  - The  indicator in the upper left corner of an image when image information is turned on indicates it is protected.
  - The  indicator does not appear when an image is not protected.

# DELETING IMAGES

Use the following operations when you want to delete images. You can delete the currently selected image, specifically selected image, all the images in a particular folder or all images currently on the memory card.

## »» IMPORTANT! ««

- Image deletion cannot be undone. Before deleting an image, make sure you no longer need it or you have a back-up copy saved on your computer, on diskette, or on some other medium.
- Be especially careful with “Deleting All Unprotected Images” operation, which deletes all unprotected images in memory.
- A protected image cannot be deleted. See “Image Protection” on page 89 for details on protecting and unprotecting images.

## Deleting the Currently Selected Image

- 1. Align the POWER/Function switch with PLAY.**
- 2. Use [▶] and [◀] to display the image you want to delete.**
- 3. Press PREVIEW/📄.**
  - You cannot delete an image that is protected.
  - You can still use [▶] and [◀] to change to another image as this point, if you want.
- 4. Use [▼] to select “Yes”.**
  - To cancel the delete operation, select “No” and then press SET, or press any other button besides [▶], [◀], [▼], [▲], SET, or the shutter button.
- 5. Press SET.**
  - Deleting a panorama deletes all of the images that make it up as well.

## DELETING IMAGES

### NOTE

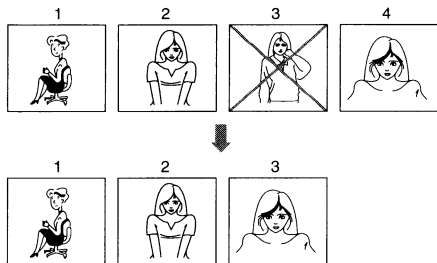

The camera does not maintain open spaces in its memory. Deleting an image causes all images following the deleted image to be shifted up.

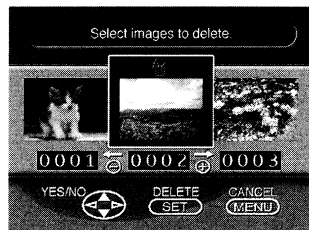

### Deleting a Single Image

1. Align the POWER/Function Switch with **PLAY**.
2. Press **MENU**.
3. Select “Delete” → “Select”.
4. Select the image you want to delete.





- Protected images are not displayed.
  - Note that the first time you display an image its  icon is turned on.
5. Press [**▼**] or [**▲**] to toggle the  mark of the selected image on and off.
    - If you want to delete more than one image, repeat steps 4 and 5.



**6. After all the images you want to delete are selected, press SET to delete them.**

- Deleting a panorama deletes all of the images that make it up as well.

### Deleting All the Images in a Folder

- 1. Align the POWER/Function Switch with PLAY.**
- 2. Press / .**
- 3. Use [▶] and [◀] to select the folder you want to delete.**
- 4. Press SET.**
- 5. Press MENU.**
- 6. Select “Delete” → “Folder”.**

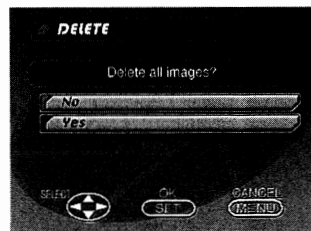

- 7. Select “Yes” to delete the contents of the folder, or “No” to abort the delete operation without deleting anything.**
  - When the above procedure is performed while there are protected images in memory, the first of the protected images appears on the monitor screen after the unprotected images are deleted.

### Deleting All Unprotected Images



- 1. Align the POWER/Function Switch with PLAY.**
- 2. Press MENU.**
- 3. Select “Delete” → “All”.**
- 4. Select “Yes” to delete all unprotected images, or “No” to abort the delete operation without deleting anything.**
  - When the above procedure is performed while there are protected images in memory, the first of the protected images appears on the monitor screen after the unprotected images are deleted.

# DPOF

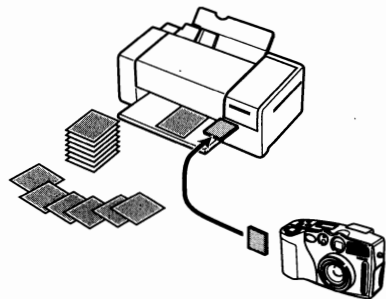
The letters "DPOF" stand for "Digital Print Order Format," which is a format for recording on a memory card or other medium which digital camera images should be printed and how many copies of the image should be printed. DPOF makes it possible for a DPOF compatible printer or professional print service to print images from a memory card without having to specify individual file names.



## Printing Specific Images

1. Align the **POWER/Function Switch** with **PLAY**.
2. Press **MENU**.
3. Select "**DPOF**" → "**Select**".
  - On the advanced menu, select "**Tools**" → "**DPOF**".
4. Use **[▶]** and **[◀]** to select the image you want to print.
5. Press **[▼]** or **[▲]** to toggle the  mark on (print) or off (do not print).
  - With this procedure, you can turn the  mark on and off for each individual image.

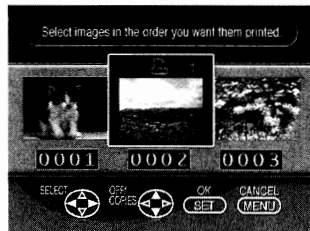

**6. Use [▼] and [▲] to specify the number of copies you want to print.**

- If you want to specify more images for printing, repeat steps 4 through 6.
- If you change your mind about printing an image, press [▼] to clear its  mark.

**7. After you are finished, press SET to exit the image specification procedure.**

## Printing All Images

1. Align the POWER/Function Switch with PLAY.
2. Press MENU.
3. Select "DPOF" → "All" → "Set print order".
  - On the advanced menu, select "Tools" → "DPOF" → "All" → "Set print order".
  - To cancel current print settings, select "Cancel print order".
4. Press SET.
  - If you selected "Cancel print order" in step 3, pressing the shutter button returns to the playback screen.

5. Use [▼] and [▲] to specify the number of copies of each image you want to print.

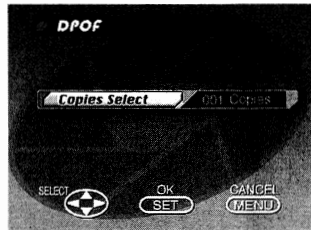

6. After you are finished, press SET to exit the image specification procedure.
  - The above procedure causes the  mark to appear on all the images in memory.

# CONNECTIONS

This camera is equipped with a VIDEO OUT terminal for connection to a television or video deck, and a DIGITAL terminal and USB port for connection to a computer or other equipment.

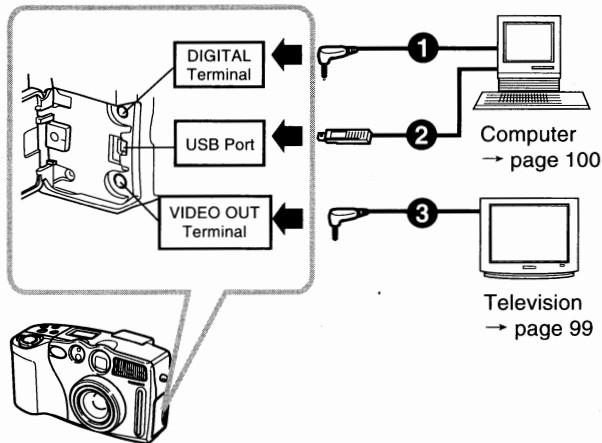

## ❶ Cables

The type of cable you should use depends on the type of equipment to which you are connecting.

## ❷ Special USB cable

When connecting to a computer, use the special USB cable and USB driver software that comes with the camera.

## ❸ Special video cable that comes with camera

## »» IMPORTANT! ««

- Be sure to turn off both the camera and other equipment before making any connections.
- Check the documentation that comes with your other equipment for information you may need to know when making connections.
- Leaving the same image displayed on a television or computer display screen for very long periods can cause the image to be "burned in" on the screen. When this happens, a faint after-image remains on the screen, even after you disconnect the camera. To avoid this, you should not leave the same image displayed on such a screen for very long periods.
- This camera does not support cable transfer of data with other CASIO digital cameras.

# CONNECTING TO OTHER EQUIPMENT

## Connecting to a Television

Images being displayed on the camera's monitor screen, whether for recording or playback can also be displayed on the screen of a connected television.

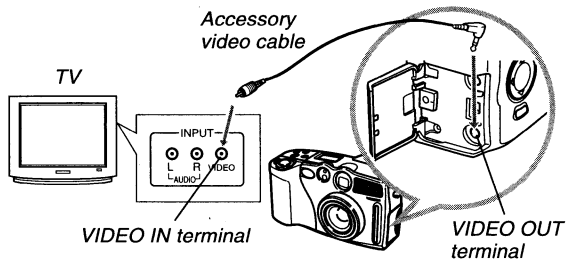

- 1. Connect one end of the video cable to the camera and the other end to the television.**
- 2. Set up the television for video input.**
  - See the documentation that comes with the television for information about how to do this.
- 3. The connection procedure is the same for both recording and playback.**

## !!! IMPORTANT! !!!

- A television must have a video input terminal like the one shown in the illustration to connect to this camera.
- Battery capacity (page 30) and other displays that normally appear on the camera's monitor screen are also displayed on the television screen.

## Selecting the Video Output Signal Mode

You can select either of two common video output modes: NTSC or PAL.

The video system you should use depends on the country where you plan to use the output signal. In the United States or Japan, for example, you should use NTSC, but in Europe you need to use PAL.

Check with your local video or TV retailer if you are unsure about which video mode you should use in your country.

## !!! IMPORTANT! !!!

Selecting PAL causes the monitor screen to go blank during video output.

- 1. Press MENU.**
- 2. Select "Set Up" → "Video Out".**
- 3. Select the video mode you want to use.**

## Connecting to a Computer

The following accessories are included with the camera to make it easy for you to connect to a computer to transfer and manage your images.

- USB cable
- USB driver software (on CD-ROM)
- Data Transfer Cable
- Photo Loader application (on CD-ROM)

## USB Port Connections

The camera's USB port and accessories make it easy to connect to a computer equipped with a USB port. First install the USB driver software that comes bundled with the camera on your computer, and then use its special USB cable to make the connection. Once connected, you can view images on your computer's display and store images on its hard disk.

- See the separate installation manual for information about how to install the driver software on your computer.

## System Requirements

Windows	Macintosh
<ul style="list-style-type: none"> <li>• IBM PC/AT or compatible computer pre-installed with Windows 2000 or Windows Windows 98, or pre-installed with Windows 98 and upgraded to Windows 2000</li> <li>• 486 or higher CPU (Pentium recommended)</li> <li>• CD-ROM drive (for installation)</li> <li>• Keyboard and mouse or equivalent input device</li> <li>• Available USB port</li> </ul> <p>* Proper operation is not guaranteed under the following conditions.</p> <ul style="list-style-type: none"> <li>• A computer upgraded from Windows 95 or Windows 3.1 to Windows 98</li> <li>• A computer upgraded from Windows 95 or Windows NT to Windows 2000</li> </ul> <p>* This USB driver does not run under Windows 3.1, Windows 95 or Windows NT.</p> <p>* In the case of Windows 2000, proper operation is guaranteed for Windows 2000 Professional only.</p>	<ul style="list-style-type: none"> <li>• Mac OS 8.5 or higher, Mac OS 8.1 with USB system extensions (iMac Update 1.0 is required)</li> <li>• Power PC G3</li> <li>• CD-ROM drive (for installation)</li> <li>• Keyboard and mouse or equivalent input device</li> <li>• Available USB port</li> </ul>

\* The USB driver may not run correctly under certain hardware configurations.



## USB Port Connection

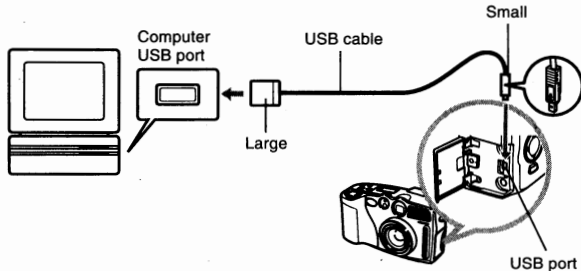

### !!! IMPORTANT! !!!

- Whenever connecting the USB cable to the camera, make sure the arrow mark on the plug is aligned properly with the arrow mark on the side of the camera's terminal.
- Plug the USB connectors into the ports as far as they will go. Incorrect connection can result in improper operation.
- The camera is not supplied power by the USB cable. Be sure to use the optional AC adaptor to power the camera whenever using a USB cable connection.
- Never disconnect the USB cable while a data communication operation is in progress. Doing so can corrupt memory data.

- Connecting the camera to a computer with the USB cable causes the "USB" to appear in the camera's indicator display. This simply means that the cable is connected but does not mean that the camera is being recognized by the computer as an external storage device. Perform the required operation on your computer to check whether the camera is being recognized by the computer as an external storage device.
- USB data communication becomes enabled whenever you connect the USB cable, regardless of whether the camera is in the PLAY Mode or REC Mode.
- Disconnect the USB cable after you are finished with data communication.
- You cannot turn off the camera while the USB cable is connected. Disconnect the USB cable first when you want to turn off the camera.

## Data Transfer Cable Connection

You can use the Data Transfer Cable to connect to your personal computer through the camera's DIGITAL terminal. Then you can save images on your computer's hard disk using the Photo Loader application.

- See the separate installation manual for information about how to install Photo Loader on your computer.

## CONNECTING TO OTHER EQUIPMENT

### Windows 2000, 98, 95, NT Workstation 4.0

The Data Transfer Cable can be connected to an IBM PC/AT or compatible that is equipped with a D-Sub9 RS-232C terminal.

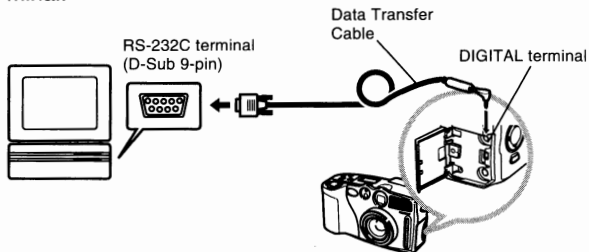

### Macintosh

You can connect the camera to the serial port (modem or printer port) of your Macintosh using the Data Transfer Cable.

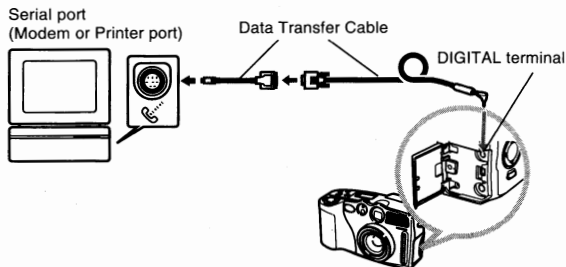

### !!! IMPORTANT! !!!

- See the documentation that comes with Photo Loader for information about system requirements.
- Be sure to turn off the camera, computer, and all peripherals (monitor, disk driver, etc.) connected to the computer before connecting the digital camera with the Data Transfer Cable.
- After connecting the camera to the computer, align the POWER/Function switch with PLAY and then turn on the computer. Note that data communication with a computer is not possible while the POWER/Function switch is in the REC position.
- Never connect or disconnect the cable while Photo Loader is running. Doing so can cause problems with program execution, can corrupt data, and can damage the camera and your computer.
- Data transfer while camera batteries are low can result in sudden shutdown of the camera. Because of this, use of the optional AC adaptor is recommended whenever performing data communication with the camera.
- This camera does not support data communication with any of the optionally available CASIO PC link software applications: LK-1, LK-1A, LK-10V, LK-11W, LK-2, LK-2A, LK-2V, LK-21.

# USING CompactFlash CARDS WITH YOUR COMPUTER

## Setting Up to Access CompactFlash Card Contents From Your Computer

You can use any of the three methods described below to access the contents of a memory card with your computer. You can use the Photo Loader software to save images on the memory card to your computer.

### CompactFlash Memory Card Slot

If your computer has a CompactFlash Memory Card Slot, insert the camera's memory card into the slot.

### PC Card Slot

In this case you need an optionally available CASIO CA-10 PC Card Adaptor. See the instructions that come with the PC Card Adaptor and the documentation that comes with your computer for details on using this type of configuration.

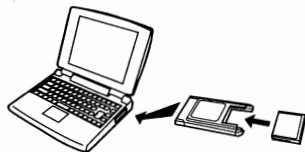

### Other Desktop Computer Configurations

Some desktop computers require a separately available PC card reader/writer and the optionally available CASIO CA-10 PC Card Adaptor to read memory card contents. See the instructions that come with the PC card reader/writer and the PC Card Adaptor for details on using this type of configuration.



## Memory Card Data

Images recorded with this camera and other data is stored on the memory card using DCF (Design rule for Camera File system) protocol. DCF protocol is designed to make it easier to exchange image and other data between digital cameras and other devices.

### DCF Protocol

DCF devices (digital cameras, printers, etc.) can exchange images with each other. DCF protocol defines the format for image files data and the directory structure for the memory card, so images can be viewed using another manufacturer's DCF camera or printed on a DCF printer.

In addition to support for the DCF protocol, your CASIO digital camera also shows dates in image folder names and image file names, which helps to make data management easier.

## CompactFlash Card Directory Tree

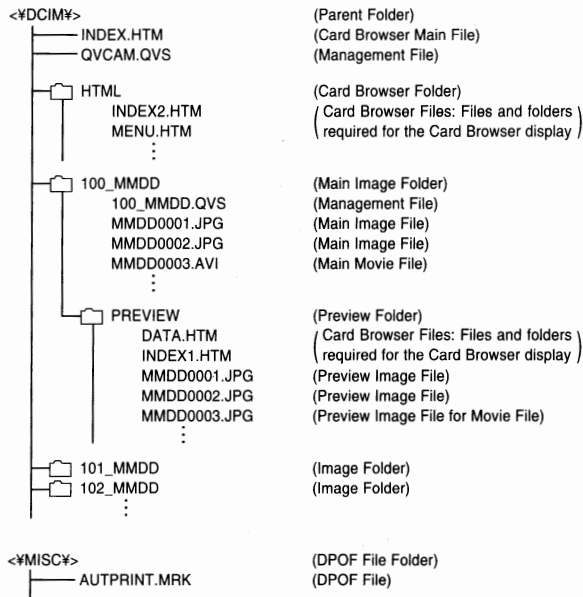

### Folder and File Contents

- Parent Folder  
Contents: All files used by the digital camera
- Card Browser Main File  
Contents: Template for card browser, which is used for viewing image previews with a web browser
- Management File  
Contents: Information about folder management, image sequence, etc.
- DPOF File Folder  
Contents: DPOF files
- DPOF File  
Contents: Printer data
- Card Browser Folder  
Contents: Files used by the card browser
- Card Browser File  
Contents: Data used by the card browser
- Main Image Folder  
Contents: Image files recorded by the camera
- Main Image File  
Contents: Still image file recorded by the camera

- Main Movie File  
Contents: Movie file recorded by the camera
- Preview Folder  
Contents: Preview images
- Preview Image File  
Contents: Preview images of still image and movie files used for temporary playback and card browser previews

### Image Files Supported by the Camera

- Image files recorded with the CASIO QV-3000EX Digital Camera
- DCF protocol image files  
Certain DCF functions may not be supported.

### Personal Computer

- This camera uses management files to manage the sequence and attributes of image files. Because of this, adding files, deleting files, changing management file contents, or changing file sequence and attributes with your computer can cause panorama images to become ungrouped. It can also result in slower image scrolling on the camera.
- When transferring CompactFlash card contents to a hard disk, floppy diskette, MO disk, or other external storage, keep everything in the DCIM folder together. Changing the name of the DCIM folder to a date is a good way to keep track of your images. However, be sure to change the name of this folder back to DCIM if you ever copy it back to the memory card for playback on the camera. This camera does not recognize any folder name besides DCIM.
- The above is also true about the names of folders inside the DCIM folder. These folders must be returned to the names assigned to them by the camera whenever you copy the DCIM folder back to the memory card for playback on the camera.
- Never delete or modify the QVS file in any way.
- We also strongly recommend that after transferring data from a CompactFlash card to other external storage that you re-format the card and delete its contents before using it to record more images.

### Card Browser

Card Browser makes it possible to use a browser application to view images recorded with the QV-3000EX.

- The HTML file generated by this camera is best viewed using Microsoft Internet Explorer 4.01 or later, or Netscape Communicator 4.5 or later. It cannot be viewed using Photo Loader.
- QuickTime is required to play back AVI movie files.

1. Press MENU.
2. Select "Set up" → "Card Browser".

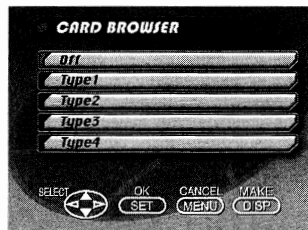

### 3. Use [▼] and [▲] to select the Format and then press SET.

There are four Card Browser formats.

Type1 ..... This is a powerful format that provides detailed information about each image and also includes a Slide Show feature.

Type2 ..... This format is a viewer with a Slide Show feature.

Type3 ..... This format shows information about each image. You should be able to use it with any browser, regardless of version.

Type4 ..... This format provides basic image viewing. Since it is the simplest option, you should be able to use it with just about any browser, regardless of version.

- Note that the Type1 and Type3 formats use Java Script, so their use requires Microsoft Internet Explorer 4.01 or later, or Netscape Communicator 4.5 or later.
- Turning on Card Browser causes an HTML file to be generated whenever you turn off camera power.
- Selecting "Off" in step 3 of the above procedure turns off Card Browser.
- Creation of an HTML file causes an INDEX.HTM file and other files to be added to the DCIM folder.

#### »» NOTE ««

Pressing DISP in place of SET in step 4 immediately starts Card Browser file generation, which is indicated by the message "One moment please..." on the monitor screen. Never turn off camera power while this message is on the display.

#### »» IMPORTANT! ««

- Though the camera's monitor screen goes blank when you turn off power, the operation lamp continues to flash for some time as the camera internally generates a Card Browser file (when Card Browser is turned on). Performing any of the operations while the operation lamp is flashing not only stops generation of the Card Browser file, it can also result in corruption of the image data on the CompactFlash Card.

Note that a Card Browser file may be corrupted if batteries are low or if the CompactFlash Card becomes full during file generation.

- If the CompactFlash card in the camera has a large number of files on it, it may take quite a bit of time for the camera to generate the required HTML files and actually turn off after you slide the POWER/Function switch towards OFF.

Because of this, we recommend that you normally leave Card Browser turned off, except when you actually want to generate HTML files.

## USING CompactFlash CARDS WITH YOUR COMPUTER

- This camera generates a Card Browser file whenever you turn off power. When the card in the camera contains a large number of files, it may take some time for the file generation operation to be performed. You can turn off the Card Browser feature if you do not want a file generated each time you turn off camera power.

## How to use the HTML file

### Viewing HTML File Contents

Load the CompactFlash card into a card slot of your computer (page 103). Now drop the INDEX.HTM file (in the DCIM folder) onto your Web browser to display a list of all images contained on the CompactFlash card.

For information about importing data from a memory card, see "Setting Up to Access CompactFlash Card Contents from Your Computer" (page 103) and "Connecting to a Computer" (page 100).

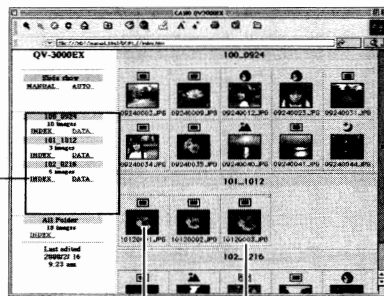

Folder name

Image

File name

Clicking on a folder name displays the following data about the images contained in the folder.





### Image Information

File size (KB)  
 Resolution (pixels)  
 Quality  
 Recording mode  
 AE  
 Light metering  
 Shutter speed  
 Aperture stop  
 Exposure comp  
 Focusing mode  
 Flash mode  
 Sharpness  
 Saturation  
 Contrast  
 White balance  
 Digital zoom  
 Date  
 Model

Click Index to return to the image list.

### Saving an HTML File

- You can use the Photo Loader application that comes bundled with the camera to easily save the images in the HTML file to a computer. See the documentation that comes with Photo Loader for details.
- Before using the CompactFlash card again (after storing its images on other media), delete all its current files or reformat the card.
- In the case of Type1 and Type3, Slide Show displays 1024 x 768 size images in the same size as 2048 x 1536 images.
- The index screen uses the contents of the Preview Folder (page 104). Images copied from another digital camera or a computer may not have preview images, and so they do not appear in the index screen. If this happens, scroll through the images on the monitor screen until the copied images appear. At this time, the camera automatically generates a preview image, which will now appear on the Card Browser index screen.

# TROUBLESHOOTING

	Symptom	Probable Cause	Action
Power Supply	No power	<ol style="list-style-type: none"> <li>1. Batteries not loaded correctly.</li> <li>2. Dead batteries</li> <li>3. Wrong AC adaptor</li> </ol>	<ol style="list-style-type: none"> <li>1. Correctly load batteries (page 38).</li> <li>2. Replace all four batteries with a set of new ones (page 38).</li> <li>3. Use only recommended AC adaptor .</li> </ol>
	Sudden power failure	<ol style="list-style-type: none"> <li>1. Auto Power Off</li> <li>2. Low battery power</li> <li>3. Use of manganese batteries.</li> </ol>	<ol style="list-style-type: none"> <li>1. Turn power back on.</li> <li>2. Replace all four batteries with a set of new ones (page 38).</li> <li>3. Replace manganese batteries with alkaline, lithium or Ni-MH batteries.</li> </ol>
	 indicator on LCD	Batteries are about to go dead.	Replace all four batteries with a set of new ones (page 38).
Recording	No recording when shutter button is pressed	<ol style="list-style-type: none"> <li>1. The POWER/Function switch is aligned with PLAY.</li> <li>2. Flash unit is charging.</li> <li>3. The message "MEMORY FULL" is on the monitor screen.</li> <li>4. Insufficient memory card capacity or no memory card loaded in camera.</li> </ol>	<ol style="list-style-type: none"> <li>1. Align the POWER/Function switch with REC.</li> <li>2. Wait until flash unit charging is finished.</li> <li>3. Delete images you no longer need from camera memory.</li> <li>4. Load a memory card.</li> </ol>
	Auto Focus cannot focus the image.	<ol style="list-style-type: none"> <li>1. Lens is dirty.</li> <li>2. The object you want to focus is not in the focus frame.</li> <li>3. Conditions make it impossible to obtain proper focus.</li> <li>4. Camera is unsteady or shaking.</li> </ol>	<ol style="list-style-type: none"> <li>1. Clean off the lens.</li> <li>2. Aim the camera so the object you want to focus is in inside the focus frame.</li> <li>3. Switch to the Manual Mode and focus manually.</li> <li>4. Use a tripod to steady the camera.</li> </ol>

Symptom	Probable Cause	Action
The recorded image is out of focus.	The focus setting is not correct.	Make sure the subject you want to focus is within the Auto Focus Frame when you record the image.
Power failure during self-timer operation	Low battery power	Replace all four batteries with a set of new ones (page 38).
Monitor screen image is out of focus.	<ol style="list-style-type: none"> <li>1. Failure to focus the image while the camera is in the Manual Mode.</li> <li>2. Attempting to record scenery or portraits in the Macro Mode.</li> <li>3. Attempting to use the Auto Focus Mode while the subject is within 50cm of the camera.</li> </ol>	<ol style="list-style-type: none"> <li>1. Focus the image before recording it.</li> <li>2. Use the Auto Focus Mode for scenery and group shots.</li> <li>3. Use the Macro Mode for close ups.</li> </ol>
Viewfinder image is dim.	Diopter is not adjusted correctly.	Rotate the diopter dial until the area inside the Auto Focus frame appears clear.
Poor color and brightness when indoors	Indoor fluorescent lighting	Shoot under incandescent or other non-fluorescent lighting (page 49).
Cannot perform movie recording.	<ol style="list-style-type: none"> <li>1. Movie Record Mode is not selected.</li> <li>2. Insufficient camera memory capacity.</li> </ol>	<ol style="list-style-type: none"> <li>1. Select the Movie Record Mode (page 62).</li> <li>2. Delete images you no longer need from camera memory.</li> </ol>
Recorded image is not saved.	<ol style="list-style-type: none"> <li>1. Loss of power before image is stored in memory</li> <li>2. Memory card cover was opened before the image was fully saved.</li> </ol>	<ol style="list-style-type: none"> <li>1. Replace all four batteries with a set of new ones (page 38).</li> <li>2. Never open the memory card cover until the image is fully saved.</li> </ol>

## TROUBLESHOOTING

	Symptom	Probable Cause	Action
Playback	Colors of recorded image are different from those on the display when image was composed.	<ol style="list-style-type: none"> <li>1. Reflection from sunlight or light from another source</li> <li>2. Image quality setting</li> </ol>	<ol style="list-style-type: none"> <li>1. Reorient the camera so that light is not shining directly into lens.</li> <li>2. Use the Recording Menu to change to a higher image quality for recording.</li> </ol>
	No [▶]/[◀] button operation during nine-page display	Button operation during page change	Wait until an image is on the monitor screen before performing a button operation.
	Cannot find an image.	<ol style="list-style-type: none"> <li>1. Memory card images recording using a camera that does not support DCF.</li> <li>2. Management files required to display images cannot be created.</li> </ol>	<ol style="list-style-type: none"> <li>1. The file management systems of cameras that do not support DCF are different from the one used by this camera. This camera cannot read cards recorded with such cameras.</li> <li>2. Make more room available on the memory card by deleting some of its images or other data.</li> </ol>
	Camera is connected to a TV, but LCD monitor contents do not appear on TV screen.	<ol style="list-style-type: none"> <li>1. Incorrect camera-TV connection</li> <li>2. Wrong TV set up</li> <li>3. Wrong video mode is selected.</li> </ol>	<ol style="list-style-type: none"> <li>1. Connect correctly using the video cable (page 99).</li> <li>2. Set up the TV correctly.</li> <li>3. Change the video mode.</li> </ol>
	Images cannot be displayed when downloaded back to the camera from a computer.	The images were on a memory card when they were opened on the computer for editing and then resaved back to the memory card.	Use the Photo Loader application to download edited images back to the camera.
Deletion	Delete operation does not operate.	All images are protected.	Unprotect the images you want to delete (page 89).

Symptom	Probable Cause	Action
Cannot select items in the Playback Menu.	Some functions are not available for playback of certain types of images.	Select a different function or change to the Record Mode.
No buttons or switches operate.	<ul style="list-style-type: none"> <li>• Malfunction due to static electrical charge or strong impact.</li> <li>• Camera is connected to a computer.</li> </ul>	Remove batteries and disconnect the AC adaptor if you are using one. Restore power and turn the camera on. If this does not work, contact your dealer or an authorized CASIO service provider.
Slide Show starts even though it is not selected.	Activation of the screen saver.	Turn off screen saver (page 84).
Nothing appears on the monitor screen.	<ol style="list-style-type: none"> <li>1. The camera is in the Sleep state.</li> <li>2. Communication over the USB cable is in progress.</li> </ol>	<ol style="list-style-type: none"> <li>1. Exit the Sleep state.</li> <li>2. After the communication operation over the USB cable is complete unplug the USB cable from the camera.</li> </ol>

# MESSAGES

---

## Can't play PANORAMA

This message appears when there is not enough memory to perform panorama recording. Delete some images from the memory card to make room for the new image.

---

## CF ERROR You must format the CompactFlash card before using it with this camera. FORMAT → MENU

Perform the following procedure whenever a memory card starts to behave abnormally.

### Important!

The procedure described below deletes all images stored in the memory card. Make sure all of your important images are backed up onto a computer hard disk or other storage medium before performing this procedure.

### To reformat a memory card

1. Connect the AC adaptor to the camera and switch to AC power or load a new set of batteries into the camera.
  - Power failure while a format operation is being performed aborts the reformat operation.
2. Press MENU.

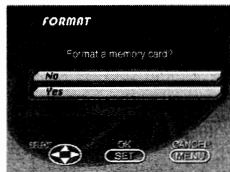

3. Use [▼] and [▲] to select "Yes", and then press SET.
    - Select MENU if you want to abort the reformat procedure without deleting anything.
    - Completion of the format operation is indicated by the message "NO IMAGE" appearing on the monitor screen. This message also indicates that the memory card was formatted successfully.
- 

## MEMORY FULL Change quality or delete unneeded images.

Not enough memory for recording in the current quality mode. Change to another quality mode, or delete some images from the memory card (pages 55, 91).

---

## MEMORY FULL Delete unneeded images.

- Not enough memory for further recording. Delete some images from memory card (page 91).
  - DCIM folder or other file (page 104) cannot be created due to insufficient memory when downloading data from a computer to the memory card. Use your computer to delete unneeded images to free up memory card space for the images you are downloading. You could also press the MENU button and format the memory card in the camera, but doing so deletes all image files currently stored on the memory card.
- 

## NO FORMAT

The memory card is not formatted. Format the memory card before trying to use it (page 35).

---



There is no memory card installed in the camera.

---

---

**RECORD ERROR** This message appears when the image you are trying to record cannot be compressed for some reason. Try changing the angle of the camera to the subject.

---

**REPLACE BATTERY!** Battery power is low. Camera power turns off automatically shortly after this message appears.

---

**There are no images on this memory card!** No images are stored in memory card.

---

**This camera cannot display the image you selected!** The JPEG image file you are trying to display is either corrupted or is a format that is not compatible with this camera.

---

# SPECIFICATIONS

**Description** ..... Digital camera

**Model** ..... QV-3000EX

**Recorded Image File Format** ..... Still images (including panoramas): JPEG (Exif. Ver. 2.1), DCF standard (Design rule for Camera File system), DPOF compatible, Movies: AVI

**Recording Medium** ..... CompactFlash card (Type I/II)

**Recorded Image Size** ..... 2048 x 1536 pixels, 1024 x 768 pixels

**Standard Memory Capacity, Number of Image Files, Computer Output Image Size**

Still					
Image size (pixels)	Quality	File size	Number of images		
			8MB memory card	64MB memory card	340MB Microdrive
2048 x 1536	FINE	1.4 MB/image	5 images	43 images	245 images
	NORMAL	1 MB/image	6 images	60 images	342 images
	ECONOMY	600 KB/image	11 images	99 images	562 images
1024 x 768	FINE	350 KB/image	19 images	167 images	943 images
	NORMAL	250 KB/image	27 images	229 images	1292 images
	ECONOMY	150 KB/image	43 images	365 images	2054 images

Movie	
<b>Storage Capacity</b>	Approximately 300KB/second
<b>Recording Time</b>	30 seconds per movie (NORMAL) 10 seconds per movie (PAST)

• The above figures are approximations only.

**Image Deletion** ..... Single image; all images in a folder; all images in memory (with image protection)

**Imaging Element** ..... 1/1.8-inch CCD (Total Pixels: 3.34 million, Effective Pixels; 3.24 million)

**Lens** ..... F2 to 2.5; f = 7 to 21mm (equivalent to 33 to 100mm lens for 35mm film)

**Zoom** ..... Optical zoom, 3X; Digital zoom: 6X (in combination with optical zoom)  
Image size is 1024 x 768 pixels when digital zoom is used.

**Focusing** ..... Contrast-detect Auto Focus; manual focus with macro mode and focus lock

**Focus Range** ..... Normal focus: 0.3m to ∞ (1' to ∞)  
Macro focus: 6cm to 30cm  
(2.4" to 11.8") (1X zoom)  
9cm to 30cm  
(3.5" to 11.8") (2X zoom)  
The focusing range is the distance from the lens surface to the subject.

## Exposure Control

Light Metering: ..... Multi-pattern, center point, spot by CCD

Exposure: ..... Program AE, Shutter priority AE, Aperture priority AE

Exposure Compensation: ..... -2EV to +2EV (1/3EV units)

Exposure Range: ..... Approximately EV7 to EV16

**Shutter** ..... CCD electronic shutter; mechanical shutter, 2 to 1/1000 second



<b>Aperture</b> .....	F2 to F8, auto switching or manual switching
<b>White Balance</b> .....	Automatic, fixed (4 modes), manual switching
<b>Self-timer</b> .....	10 seconds, 2 seconds
<b>Built-in Flash</b>	
Flash Modes: .....	AUTO, ON, OFF, Red eye reduction
Flash Range: .....	Approximately 0.5 to 4 meters (1.6' to 13.1')
<b>Recording Functions</b> .....	One-shot, continuous, movie, panorama, landscape, night scene, portrait, self-timer, macro
<b>Monitor</b> .....	1.8" TFT, low-glare color HAST LCD (122,100 pixels, 555 x 220)
<b>Viewfinder</b> .....	LCD Monitor or optical viewfinder
<b>Clock</b> .....	Built-in quartz digital timepiece for time and date recording and storage with image data; auto calendar up to 2049
<b>Input/Output Terminals</b> ....	DIGITAL IN/OUT, USB port (special mini port), AC adaptor connector, VIDEO OUT (NTSC, PAL)
<b>Power Supply</b> .....	Four AA-size alkaline or lithium batteries Four AA-size nickel-metal hydride rechargeable batteries (NP-H3) AC adaptor (AD-C620) AC adaptor charger (BC-3HA)

**Battery Life**

The values noted below indicate the number of hours before battery failure under normal operating temperature (25°C). These values are for reference only, and do not guarantee that any particular set of batteries actually will provide the service life indicated. Low temperatures shorten battery life.

Type of Operation	AA-size Alkaline Batteries LR6	AA-size Lithium Batteries FR6	AA-size Ni-MH Batteries NP-H3
Continuous Playback	145 minutes	270 minutes	170 minutes
Continuous Recording	210 shots	900 shots	660 shots

- The above figures are approximations only.
- The above guidelines are based on the following battery types:  
Alkaline: MX1500 (AA) DURACELL ULTRA  
Lithium: Energizer
- Battery life varies with brand.

Continuous recording values show the number of shots without using the flash. The number of shots depends on use of the flash and whether flash is turned on or off.

**Power Consumption** .....

Approximately 6.6W

**Dimensions** .....

134.5(W) x 80.5(H) x 57.5(D) mm  
(5.3"(W) x 3.2"(H) x 2.3"(D))

**Weight** .....

Approximately 320g (11.2 oz)  
(excluding batteries)

**Standard Accessories** .....

Neck strap; lens cap; cap holder; soft case; USB cable; video cable; User's Manual

## SPECIFICATIONS

- This camera does not have a separate battery to power its clock. Clock settings are cleared whenever power to the camera is cut off (by batteries going dead while the camera is not connected to an AC power outlet with the AC adaptor) for about 24 hours. After power is resumed, either by loading fresh batteries or connecting to an AC power outlet, you will have to set the correct time and date again.
- The liquid crystal panel built into this camera is the product of precision engineering, with a pixel yield of 99.99%. This also means, however that 0.01% of the pixels can be expected to fail to light or to remain lit at all times.

For the latest information about CASIO Digital  
Cameras and accessories, visit our website at:

<http://www.casio.com/>



**CASIO®**

**CASIO COMPUTER CO.,LTD.**  
6-2, Hon-machi 1-chome  
Shibuya-ku, Tokyo 151-8543, Japan

Printed on recycled paper.

K716FCM2PMJ  
MA0009-007508D Printed in Japan