

FITTING AN EGA CARD TO AN IBM 5155.

H. Holden 2016. Updated 7 Feb. 2016.

In *graphics* mode the CGA card has a limited color palette. This consists of two palette systems: One Background color plus Red, Green or Brown, or in the other palette Cyan, Magenta or White. Although in intensified mode the Brown becomes a Yellow due to processing inside the CGA monitor.

There can be 16 colors selected in *text* modes (8 normal and 8 intensified) numbered 0 to 15.

Running Basic and selecting screen options, Screen 0, Screen 1 and Screen 2 are the only Basic commands accepted for screen variations when using a CGA card.

Colors are numbered:

0 = BLACK

1 = BLUE

2 = GREEN

3 = CYAN

4 = RED

5 = MAGENTA

6 = BROWN (with 5153 monitor)

7 = WHITE

Colors 8 to 15 are the intensified versions in the same sequence and with the 5153 monitor, brown becomes yellow.

(The test program CGACAL is able to achieve what looks like a graphics display of all 16 colours as it operates in a text mode, not a graphics mode where the palette is more limited)

Screen modes selectable via BASIC with the CGA or EGA card:

Screen 0

Two Variants: This is a screen which has two modes of operation it appears, depending on the sequence it is entered. Going from DOS (3.3) directly to the supplied version of BASIC the screen starts in Screen 0 and it is a 25 row x 80 column text mode. However if one then selects Screen 1 (320 x 200 graphics mode) and then returns to Screen 0, Screen 0 is then in a 25 x 40 text mode. Then for example if Screen 2 is selected (a 25 x 80 monochrome text mode) and one again returns to Screen 0, Screen 0 is then in the 25 x 80 mode again. This effect is identical, whether it is the CGA, or EGA card that is being used.

In the Screen 0 text mode (either variant) the Basic Color command, has the format Color A,B,C then A is the text color, B is the text background color and C is the border color.

Screen 1

This is a 320 x 200 graphics screen which displays text in a 25 x 40 mode. In this mode the color command is quite different: Color D,E where D is the background color and E can have a value of 0 or 1. If 1 is selected the text assumes a white color and the color palette available is Cyan, Magenta or White. If 0 is selected the text assumes a Brown color and the palette available is Red , Green and Brown.

Screen 2 is a 25 x 80 monochrome text mode.

On the other hand using the **EGA** card, driving a CGA monitor, all 16 colors in graphics modes are supported for the palette, which makes better use of the CGA monitor. So it makes sense to use the EGA card rather than the CGA card to gain this improvement even if an EGA capable monitor is not used.

(To fit the EGA card to the IBM5155 and using an IBM 5153 monitor, the motherboard switch settings must have switches 5 & 6 on, and the block of 4 switches on the EGA card must have 1,2 & 3 off and switch 4 on. Also jumper P3 on the EGA card should connect pins 1 & 2 . For use with a CGA monitor jumper P1 should connect pins 2 & 3)

Once the EGA card is fitted two additional screens become available in BASIC:

Screen 7 is a 320 x 200 graphics mode screen. In this screen the color command operates as follows:

Color A,B where A determines the text color and B the background color. The palette though, for a graphic, can have any color 0 to 15.

Screen 8 is a 640 x 200 graphics mode again with 16 colors available.

So both screen 7 and screen 8 are a significant improvement over screen 1 with the expanded color palette.

If an EGA monitor is used (the switch block on the EGA card must then be set to switch 1 off, switches 2 & 3 on and switch 4 off) then **Screen 9** becomes available. This is a high Horizontal (H) scan rate (21.85 kHz) high resolution 640 x 350 graphics screen. The internal amber 5155 monitor cannot lock to this.

Also: Although the EGA card replicates the functions of the CGA card, it can give imperfect results on some programs written for CGA. For example running CGACAL in DOS, the lower half of the image fails to intensify the colors. According to IBM's EGA card document several of the CRTC registers differ between the CGA and EGA adapter and that some attributes may display differently.

Apparently there were also some screen image centering problems with the CGA card.

I'm not surprised at all by this because looking at the horizontal (H) sync pulse and blanking interval area from a CGA card composite video output shows that the H sync pulse is hard over to the right hand side of the H blanking interval and is only just complete before the scan starts and the H blanking interval is very short compared to industry standard video for the CGA composite video signal:

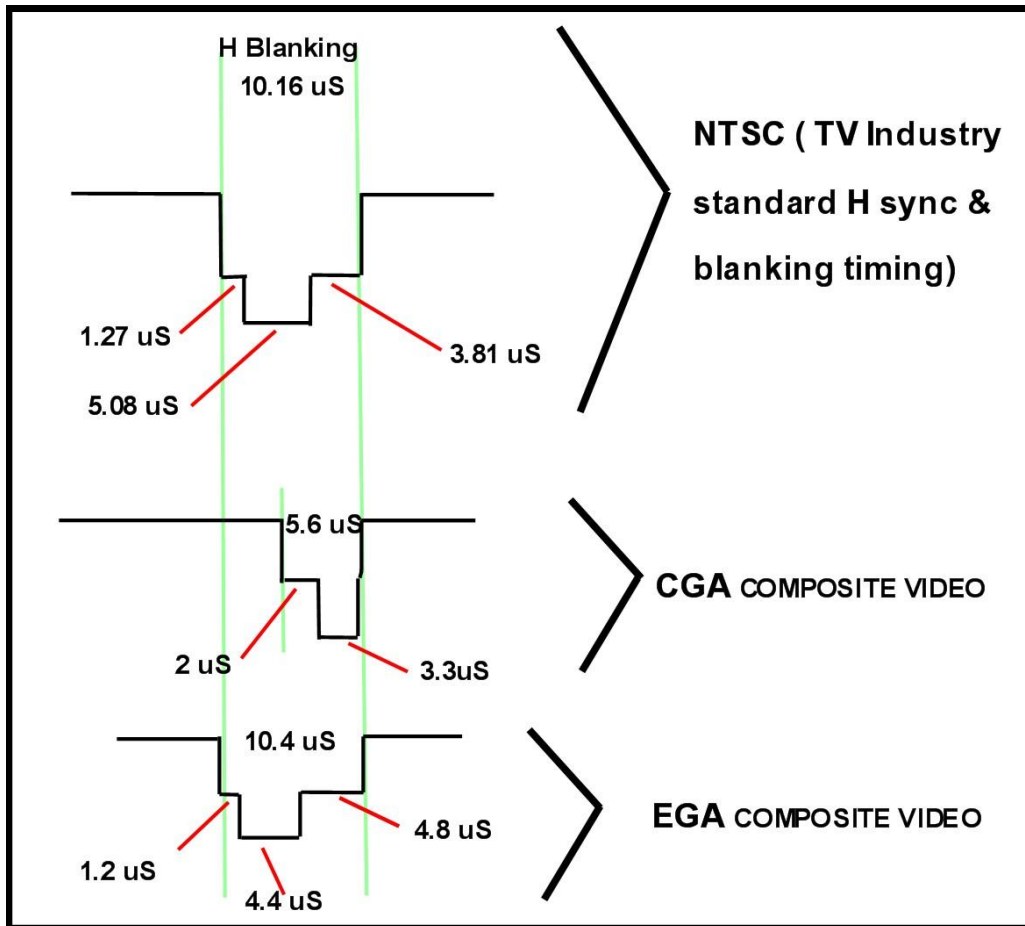

The diagram above shows what was seen on the scope, comparing the EGA and CGA cards in the horizontal sync pulse and blanking intervals. (EGA card running in normal 15.75 kHz Horizontal scan rate mode).

Clearly IBM paid a lot more attention to the timing of the H sync pulse & blanking area to get it closer to standard NTSC video for the EGA card than they did for the CGA card, which to some extent was odd since they didn't have a composite output on the EGA card, but I think they intended to have one on a future "feature adapter".

(The position of the sync pulse inside the blanking interval affects the horizontal screen centering of the image because the monitor's horizontal hold or AFC feedback/flywheel circuit compares the phase of the H sync pulse with the phase of the CRT's horizontal flyback to generate the control voltage for the horizontal oscillator frequency. So turning the H hold control on the monitor, or shifting the position of the H sync pulse inside blanking, will both affect the horizontal picture centering. Of course the centering can only be adjusted so much with the H hold control, before it drops out of H lock. Some monitors have an internal H Phase control so as to be able to adjust the H picture centering when the H hold control has already been set to its optimal position)

In the case of the EGA card it is also “six color signal system”. R,G & B are the most significant bits and r,g & b the least significant bits. The more significant bit has twice the value of the least significant bit, so adding the least significant bit or LSB to the MSB would increase the intensity by a factor of 1.5 for each color. This arrangement is different than the CGA card (see below). However when the EGA card is set to drive the CGA monitor the least significant bits are not used, except for the g channel which is used as the intensity signal instead.

Fitting a feature adapter to the EGA card:

In the IBM5155, the drive to the internal monitor is a composite video signal borrowed from the RF modulator connection on the CGA card. It is the same as the signal present on the composite output RCA connector on the CGA card. However, the internal amber monitor didn't really need the color sub-carrier part of the composite video signal and in fact it is better without as the screen graphics on the amber monitor are clearer. The amber monitor though is very good for writing text/programs as it is close to the keyboard and very easy to read.

The circuit below shows how to generate a monochrome video signal to drive the internal amber monitor in the 5155. The parts were simply built and hand wired onto a rectangle of plated through hole prototype board, and the board plugged onto the “feature connector” of the EGA card.

All of the signals required to generate the monochrome composite signal are available on the feature connector. It is also possible to generate a color sub-carrier too to make full composite video, but a lot more parts are needed. The sub-carrier if available would be introduced to pin 2 of the 74LS244 as shown in the diagram below with the red star. Fortunately the internal amber monitor only requires monochrome composite video, so this simplifies things greatly.

Also, the video signal will always have the 15.750 kHz horizontal scan rate (when the EGA card is configured with its board switches to drive a CGA monitor), so the internal monitor locks fine to the video signal.

If the EGA monitor is used instead and the EGA card is operating in the high resolution mode, the H scan rate goes above 21.85 kHz and the internal amber monitor cannot

lock to that. So if one wants to go to the IBM5154, and use those modes the internal monitor becomes useless.

I think its better to stick to the CGA monitor with the EGA card for a 5155 computer, if one wants to keep the beautiful internal amber monitor in the 5155 working normally.

The circuit of the required “Feature Adapter” is shown below. The video output can also be linked to J1 on the feature adapter (which is one of the RCA sockets on the rear of the card) so that it is available for an external monochrome monitor too.

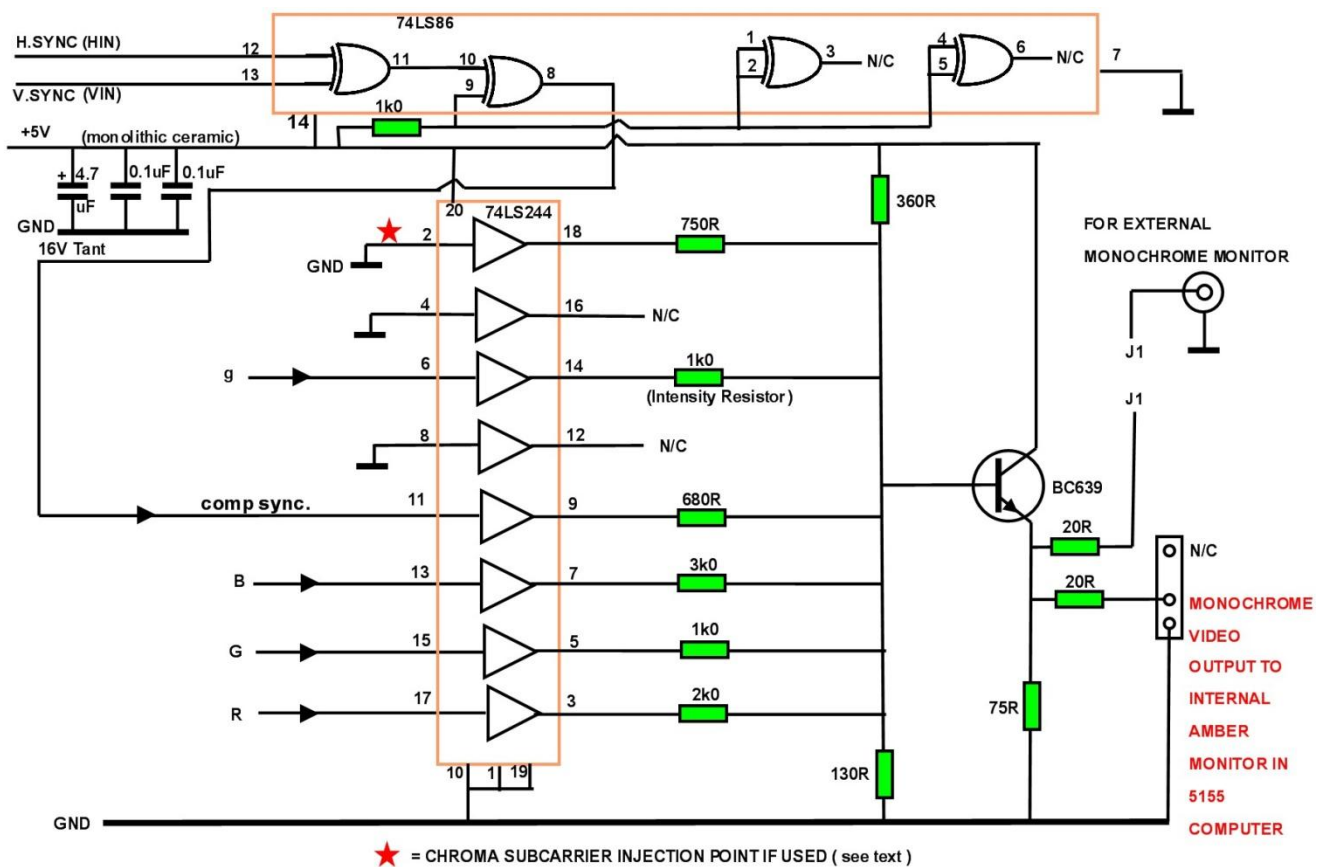

As seen above, the resistor values are the same as the ones IBM used on their CGA card to help to create a composite video signal output from the R,B & G signals. Except IBM used a 680 R intensity resistor, but this was a bit extreme so I increased it to 1k.

The required connections are available on the EGA card's feature adapter:

**LOOKING INTO THE TERMINALS OF THE IBM
EGA CARD FEATURE ADAPTER CONNECTOR :**

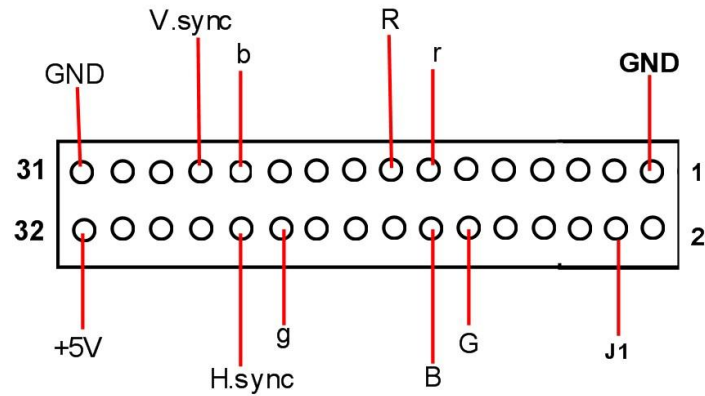

The photo below shows a feature adapter built on some prototype pcb. In this case the IC's have been kept out of sockets to keep the profile low and the components mount on their sides. It gives more room between them and the card, if there is one, in the adjacent ISA slot.

The connector on the lower right hand edge is for the existing plug to the internal amber monitor it gives more room between them and the card, if there is one, in the adjacent ISA slot.

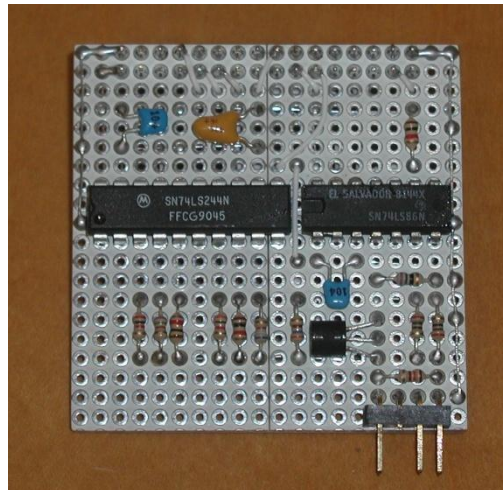

Rather than having a hand wired feature adapter, a pcb would be better, so I have designed one, it would need to be made by a pcb house. All the pads (and the vias in red) are placed on a 2.54 mm grid. This is the view looking from the pcb top, the blue tracks are on the bottom surface black tracks on the top:

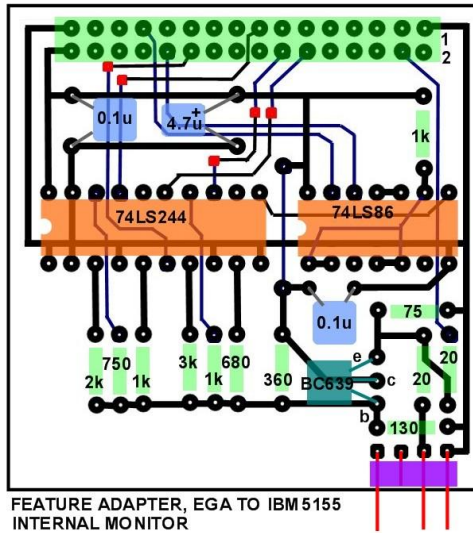
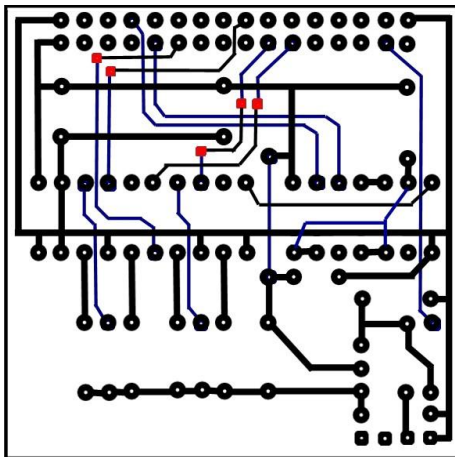
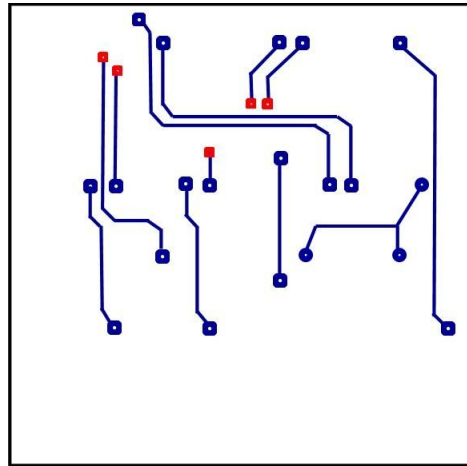
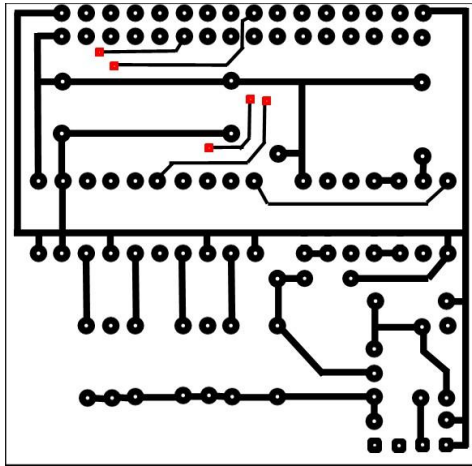

A BC639 transistor is being used rather than a 2N3904 because the BC639 is much more robust (but both work).

On IBM's original CGA card the intensity signal was mixed onto the transistor base with a 680 Ohm resistor, call that the "intensity resistor". This value sets the proportion of image intensity increase seen in the composite video signal to the internal amber monitor (or an external composite monitor) using a CGA card, and was not exactly identical to the proportion of intensity increase generated by the video drive circuitry for the R,G & B channels in the actual CGA monitor itself when the intensity signal is ON (See below how the 5153 monitor processes the intensity signals)

One curio about the 5153 CGA monitor is that the intensity signal dynamically disables the contrast control in real time (not on the average). For example with an intensified image or graphic, the contrast control has no effect on it, but still can control the intensity of any un-intensified text or graphics (the intensity signal cuts off transistor Q251 and disables the contrast potentiometer) . Also the other widely known feature of the 5153 monitor is its ability to display un-intensified yellow as brown. This function is implemented by transistor Q206 in the monitor.

To keep roughly about the same proportions for the EGA card, for intensifying a composite video signal, the g signal (which acts as the intensity signal when an EGA card is configured to drive the CGA monitor) uses the same value resistor or 680 Ohms, but I think its better at 1k.

How much intensity (signal amplitude) increase does the intensity signal provide in the composite video output with the resistive mixing arrangement chosen by IBM ? The values from their CGA card including a 680 ohm intensity resistor.

Looking at low intensity white (color 7) the video signal voltage (excluding the sync pulse level) is close to 0.355 V. The sync pulse measured 0.265V. In "industry standard video" the sync pulse is usually 0.3V amplitude therefore all measurements taken and presented here will be up-scaled a little by a factor of 0.3/0.265 or a small factor of 1.132. The reason being that in theory at least the proportions of what is known as a "peak white" in a standard monochrome video signal should be composed of 0.3V amplitude of sync pulse level and 0.7V amplitude of maximum video signal, the peak to peak total being about one volt. This is the level that should be generated across a 75 ohm load or terminating resistor.

The table below shows the measured and slightly scaled voltages:

Indeed the intensified white level corresponds to peak white in a standard video signal of about 0.7V.

	RED	GRN	BLU	WHT
NORM	0.113v	0.221v	0.068v	0.402v
INTEN	0.419v	0.532v	0.385v	0.707v

(Though without the scaling the actual peak white voltage is 0.625 V, not 0.707 and IBM's sync pulse is a tad lower in level at 0.265V rather than 0.3v when the transistor and its series 20 ohm resistor is terminated into a 75 ohm load).

In any case it is easy to see a few interesting things. Looking at the way white is intensified the signal level is lifted by a factor of about 1.76 going from normal white (color 7) to intensified white (color 15).

However the separate colors are significantly and differently intensified, red by a factor 3.75, green by 2.4 and blue by the most at 5.66. This occurs because of the near fixed increase in level provided by the current via the intensity resistor and the relative proportions of the red green & blue signals created by the resistive mixing to start with.

As can be seen the individual voltages of each color add up to white level in the normal mode, but in intensified mode they do not.

The normal white (or the luminance signal created by IBM, with their resistive mixing circuit, to represent white, composed from the 3 primary colors) is about 17% Blue, 55% Green and 28% Red

In NTSC video the Y or luminance signal (which contains the brightness information of the video image) is usually composed of 11% Blue, 59% Green and 30% Red, so IBM did not exactly stick to this standard, but it is fairly close.

(It seems like another of many examples where the computer industry and TV/video industry were not in any way working together, despite the fact that TV sets were commonly becoming display devices for computers & games. The same thing occurred with the sync pulse standards in early digital video games. Atari's Pong for example; they didn't conform to the TV standards and there were picture centering issues because the H sync pulse was in the wrong position inside H blanking)

The intensified individual color values have little meaning, on their own, but at least intensified white does not exceed industry standard video signal peak white level voltage values so it would not overdrive a standard composite video monitor input or overdrive a standard RF modulator input.

The photo below shows a graphics (screen 8) image from a simple BASIC program I wrote to show the 5153 picture and for comparison how it displays on the internal amber monitor. This program gives a color-bar pattern like CGACAL but also showing two text intensities. (the darkish grey broad horizontal band above the screen centre over the top 1/3 of the screen is an artefact of the digital camera photo)



IBM5155 AMBER MONITOR BEING DRIVEN BY HOME MADE FEATURE ADAPTER ON IBM EGA CARD



As can be seen from the above, the feature adapter described here gives a very good result driving the internal amber monitor from the EGA card.

For a direct comparison, see the image below with the program CGACAL running on a standard IBM CGA card, feeding the monitor as it does in the 5155

CGACAL PROGRAM AS IT APPEARS ON AMBER MONITOR RUNNING WITH A CGA CARD: NOTE INTERFERENCE ON COLOR BARS FROM CHROMA SUB-CARRIER.



Notice how the presence of the color sub-carrier interferes with the monochrome display to produce fine vertical lines of dark and light on the color bars. This occurs because of the excellent high frequency video response of the amber monitor and it responds to the color sub-carriers as though it were changes in luminance signal amplitude.

Running the amber monitor from a video signal devoid of the chroma sub-carrier is helpful.

IBM could have done this but it would have required two buffer output transistors and two sets of resistive mixers, one to feed the external RCA connector to have the signal complete with the color sub-carrier, and a separate feed to the internal monitor. But they didn't, instead to drive the internal monitor they simply hijacked the output connector on the CGA card that was intended to drive an RF modulator.

I also took a screen photo of the 5153, with the contrast control reduced to zero, and as can be seen from the image below the contrast of intensified video is not affected at all and just the un-intensified parts of the image are reduced to a low value. This is noted above where due to the internal electronics in the 5153 that are arranged to do this; the contrast control is dynamically disabled on intensified video. I have never seen a monitor where the contrast control function is dynamically altered like this. It is a very interesting and unusual effect:

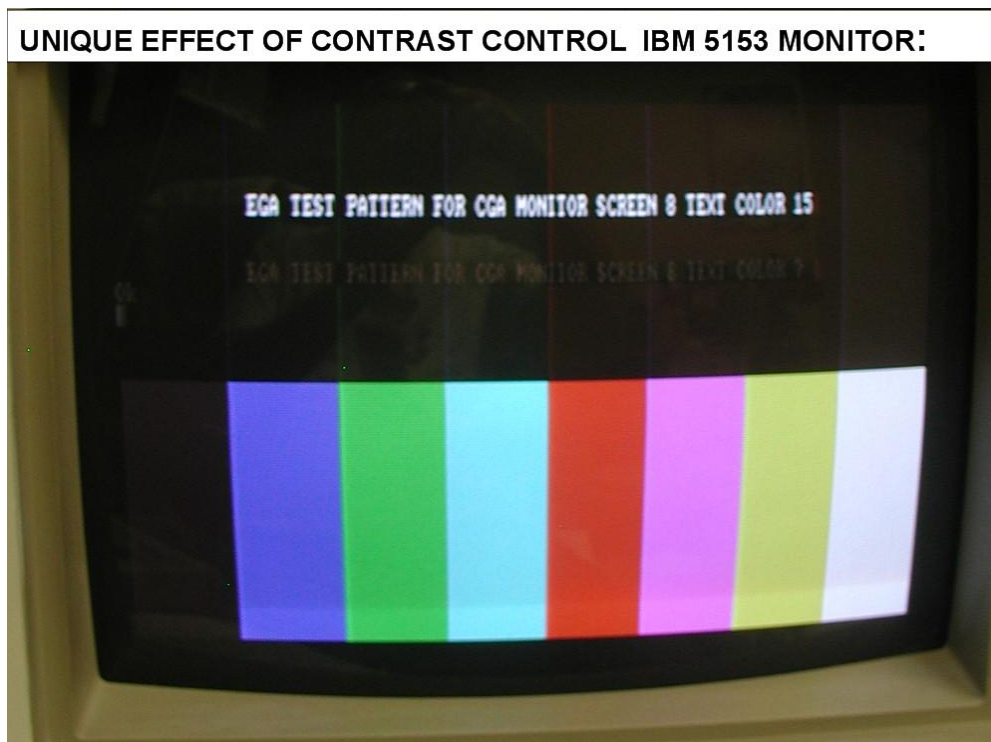

The feature adapter described here works equally well with a Vega Video-7 EGA card. One advantage of this card, over IBM's EGA card, is that it comes with some interesting software utilities. The photos below show one of their test screens, and how it looks on the IBM's 5155's amber monitor:

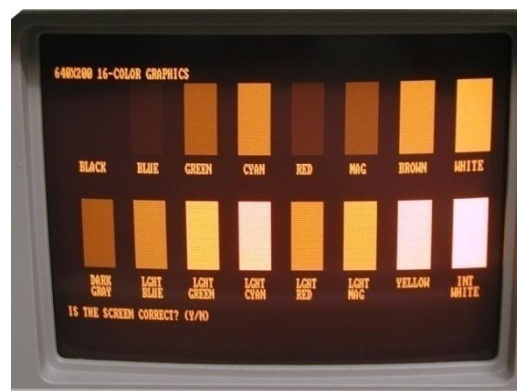
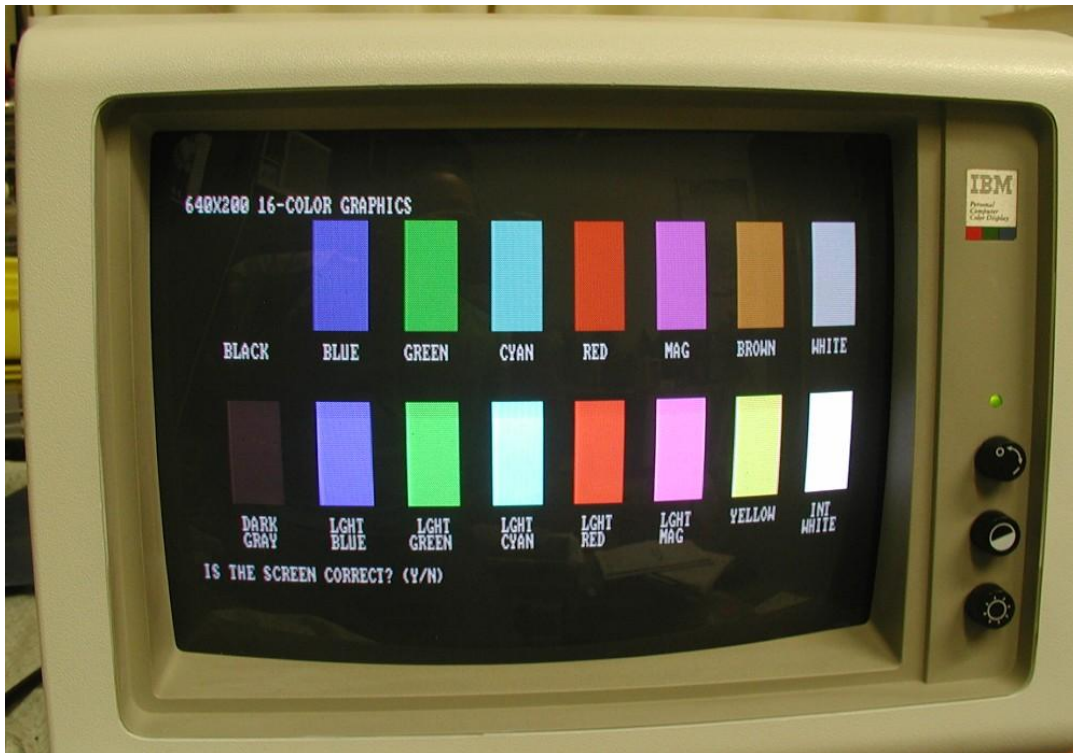

More about the interesting 5153 monitor: Intensity signal adds “White”:

Firstly a good question would be:

How much exactly does the intensity control signal affect the image intensity for each R, G & B color and for any combination of colors?

Partly this question is not entirely logical because the un-intensified part, of any text or graphic, is under manual contrast control and the intensified graphic is not, so the answer would depend on the contrast control setting. But if the contrast control is at maximum, the amount can be calculated or measured.

Firstly a simplified schematic of the 5153’s signal processing system:

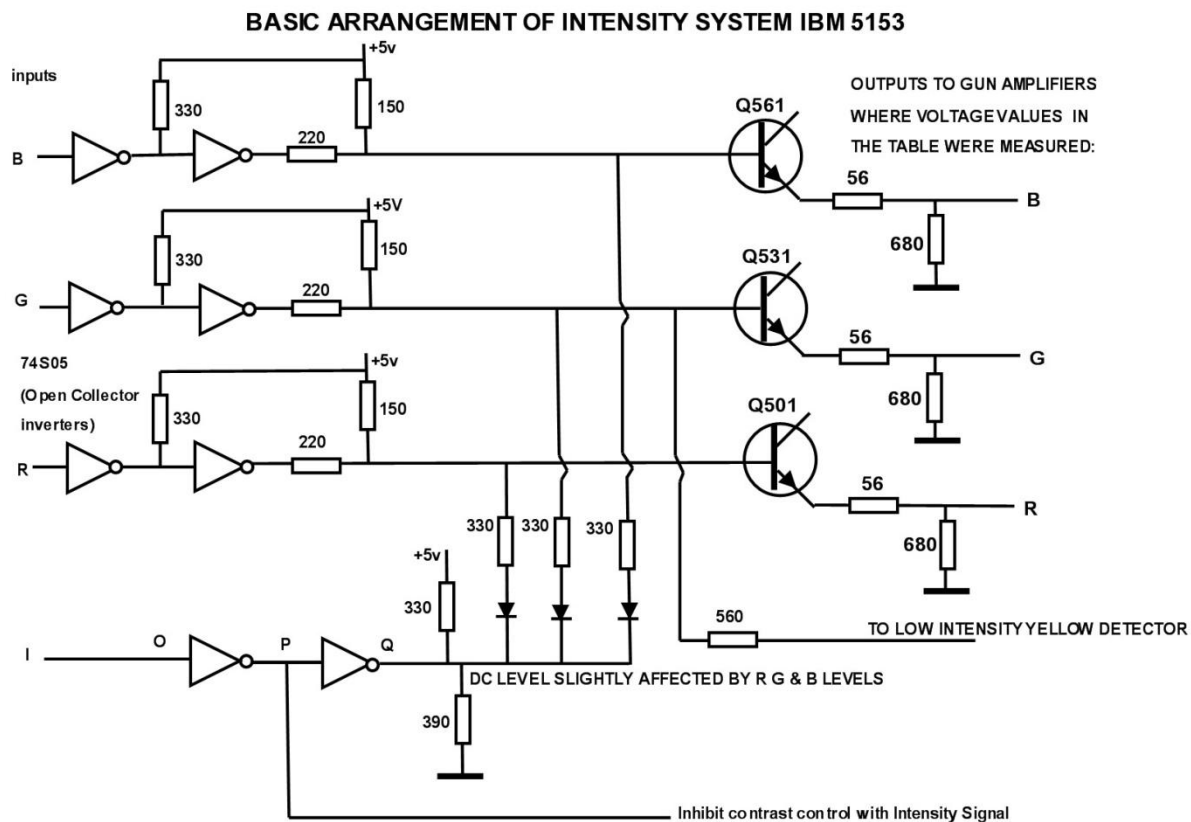

Of note, when the intensity line goes to logic high, the point Q on the circuit assumes a voltage set by the resistors alone, because the output of the inverter gate is an open collector type. In the low intensity mode, point Q assumes a low voltage and is fairly

stable. However in the high intensity mode voltage at point Q is not rigid and the signal on one channel, say R,G or B affects a little the amplitude on the other channel.

This was confirmed as shown in the table below where the output voltages (at the junction of the 56R and 680R of this circuit were measured, above black level) on a Tek 2465B scope with well calibrated cursors. It is a very interesting finding (note the colored numbers on the table are not an accurate representation of the actual color, just a reminder of the basic color associated with the color number):

IBM 5153 CGA MONITOR COLOR PROCESSING									
DRIVE LEVEL : Volts peak above black level to GUN amplifiers.									
COLOR NUMBER									
	0	1	2	3	4	5	6	7	
R	0	0	0	0	1.00	1.00	1.00	1.00	N O R M A L
G	0	0	1.00	1.00	0	0	0.64★	1.00	
B	0	1.00	0	1.00	0	1.00	0	1.00	
R	0.40	0.40	0.40	0.40	1.12	1.24	1.24	1.30	I N T E N S I F I E D
G	0.40	0.40	1.12	1.24	0.40	0.40	1.24	1.30	
B	0.40	1.12	0.40	1.24	0.40	1.24	0.4	1.30	
	8	9	10	11	12	13	14	15	

★ = LEVEL REDUCED BY Q206

In the low intensity mode, the values are very straightforward. The “brown detector” involving Q206, which detects low intensity yellow, reduces the green drive to about 64% of its normal value (see logic circuit below).

Very interesting things happen in the high intensity mode. Firstly in color 8 (light grey), 0.4V is added to each color R, G & B which lifts the average level.

Looking at the intensified separate colors first, either the intensified Red, intensified Green or intensified Blue; the color drive signal itself (when a single primary color is intensified alone) is only increased by 12% over the un-intensified color.

Therefore consider an intensified Red (color 12) for example; due to the fact that the other two color channels G & B are also increased by 0.4V each this result is equivalent to a *white* signal with an overlaid red comprising $B = 0.4$, $G = 0.4$ and $R = (0.4 + 0.72 = 1.12)$, so it is equivalent to having a red 0.72V signal imposed on a 0.4V white. This explains why the intensified colors have a pastel look to them, or look a bit like colors that have had their white level increased like adding white to make pastel paints (this is a broad analogy because paint mixing is subtractive mixing, not additive mixing with light).

When more than one color gets intensified, take Cyan for example (color 11), the value of intensification increases from 12% to about 24% for each active color *when two colors are simultaneously intensified*. This occurs because of the color channel interactions and the DC level at point Q on the circuit diagram shown above being affected by the amount of signal on each channel. Therefore, in this case, the output becomes equivalent to a white signal of 0.4 with an overlaid Cyan (equal blue & green) of about $1.24 - 0.4 = 0.84$, (vs say the 0.72 for intensified red alone).

So intensified Cyan for example has a brighter look than intensified red for two reasons, firstly it is brighter by approximately a factor $0.84/0.72$ and secondly two CRT phosphors the green and the blue are simultaneously excited on the crt face.

The situation is the same *for any combination of two colors*, for example Magenta or Yellow, as well as Cyan, and the level for each active color is 24% higher than in normal color mode.

When color 15 is selected, this again causes an increase in the voltage at point Q, and now each individual color R, G & B is increased to 1.3V or 30 % higher than normal un-intensified mode. All this is shown in the table.

The intensification signal on IBM's composite video output is quite different to the intensification processes in the 5153 monitor and in no way did IBM attempt to make the intensification seen on a composite monitor (TV) match this unique situation in the 5153 monitor.

The simplified circuit logic below shows how the monitor detects low (normal) level yellow to create brown by lowering the Green drive by 64%:

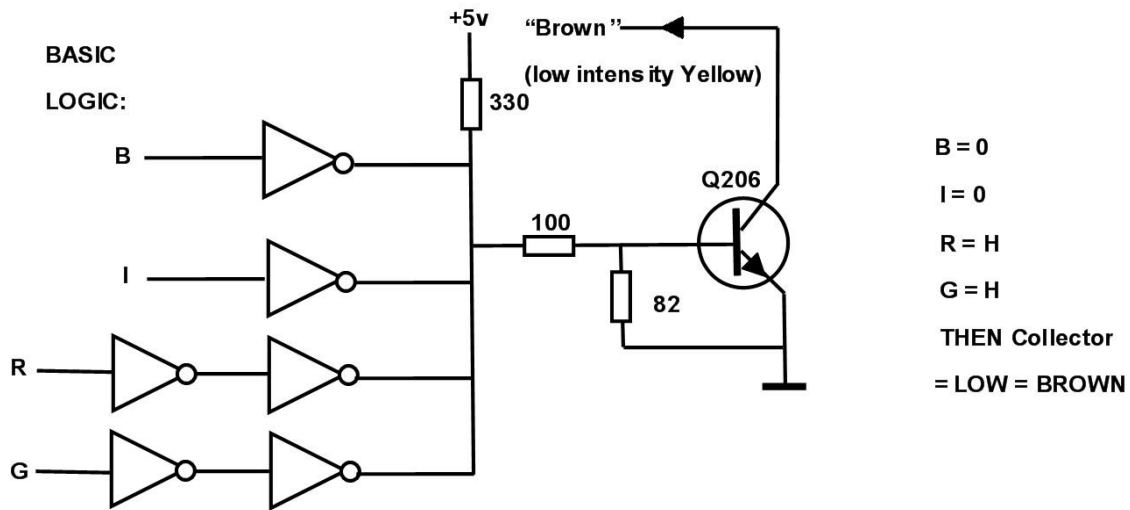

Vertical Scan Issue:

Both of my 5153 monitors have a very subtle defect in the vertical scan which produces what appears to be a white horizontal line just below the top of the raster. This is not due to aged electrolytic capacitors and it is not an un-blanked retrace line. It is the way the vertical scan output stage has been designed. I would expect if one looks closely it is visible on all 5153's to some extent. A photo of just the scanning raster (no video feed to the monitor) is shown below. The defect is due to a small glitch in the vertical yoke scanning current, just after the start of vertical scan. It causes two of the scanning lines to slightly pair together to produce a faint white line near the top of the screen. It is actually a little easier to see it with just the scanning raster, but it is there all the time:

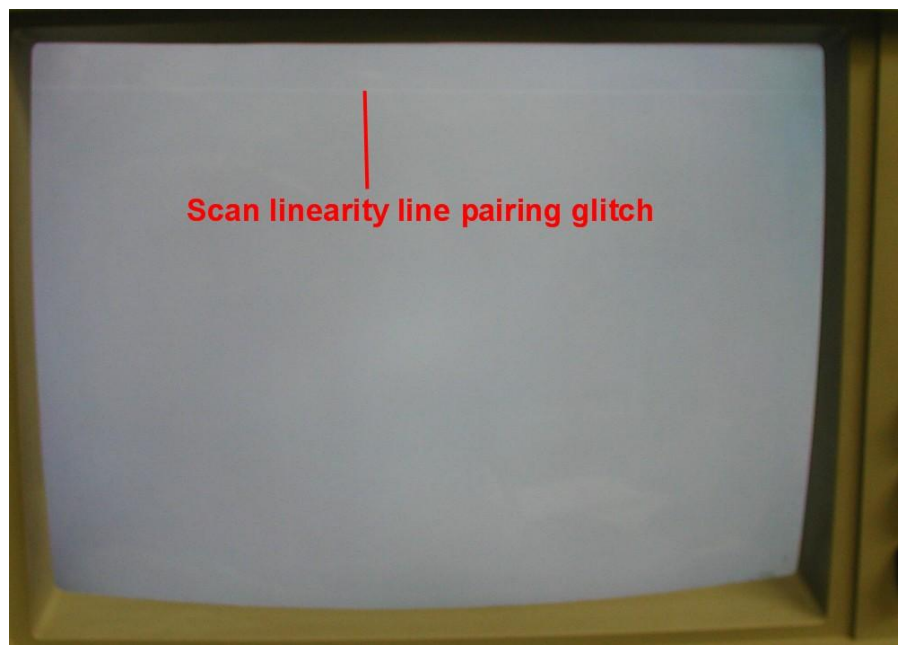

It is possible that when these monitors were new it wasn't so obvious and it is much more difficult to see on an image with graphics or text than just the plain raster, but it is still there.

Examining this problem:

Referring to IBM's schematic.

The vertical output stage (which drives the vertical deflection yoke) looks very similar to the typical vertical output stage in a TV, but has some design variations. IBM modified it or designed it this way. The partial vertical output stage circuit is shown below. How it works:

IBM 5153 VERTICAL OUTPUT STAGE

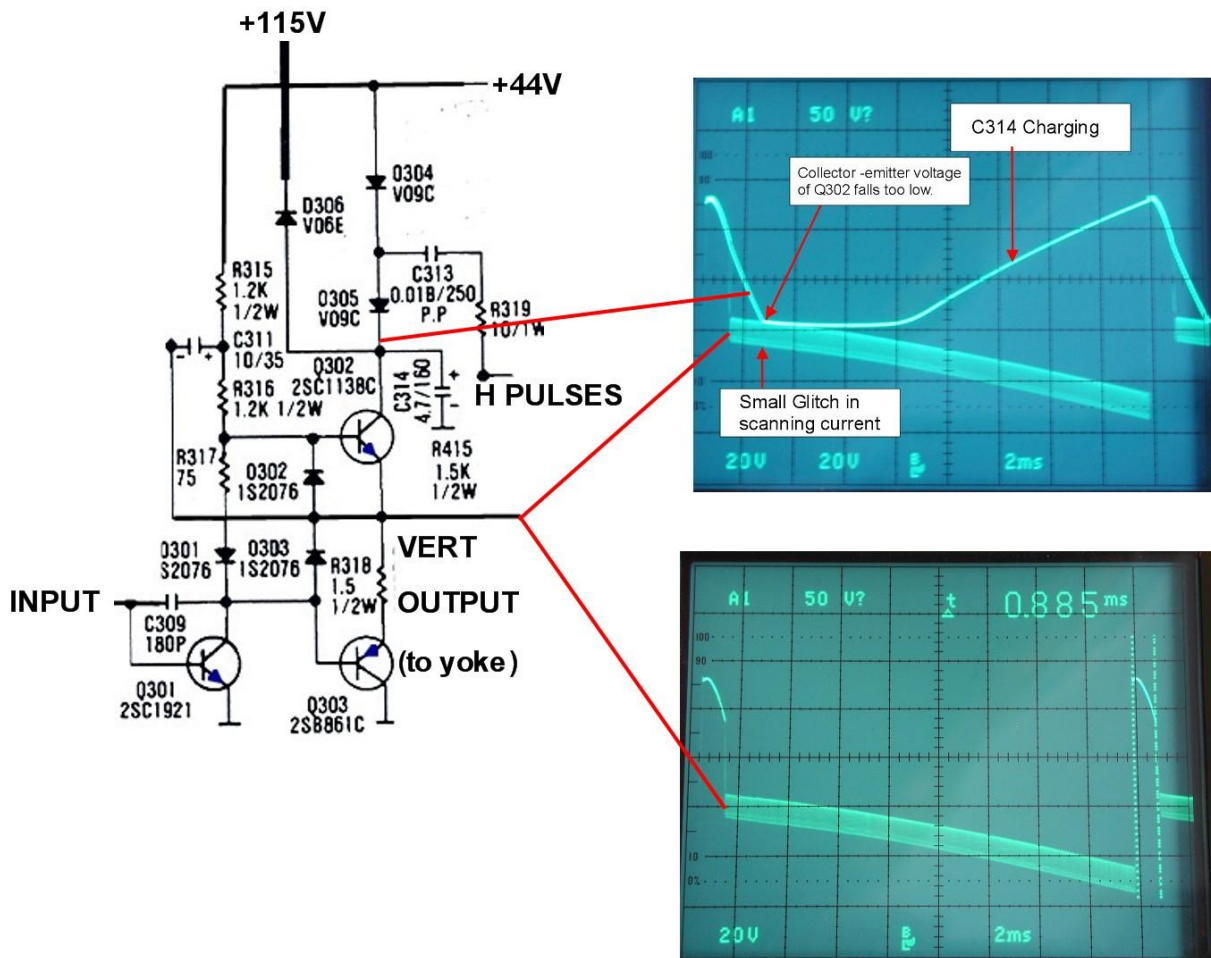

(The missing emitter arrows are drawn in blue)

IBM chose to power the collector of the upper (NPN) output transistor not from the 115V supply directly but from the 44V supply which is boosted up to about 90v just before flyback. Conduction of PNP transistor Q303 is primarily responsible for the active scanning current and Q302 primarily responsible for the flyback.

The lower scope trace shows the vertical amplifier's output voltage, sloping downward due to increasing conduction in Q303 and increasing yoke current. As seen the vertical flyback time is 0.885 mS.

Pulses from the Horizontal circuit are coupled via R319 and C313 and are rectified by the diodes D304 and D 305 (looks like 0304 and 0305 on the schematic) so as to charge capacitor C314 on the collector of Q302. This capacitor can be seen to be charging before about half way into the start of the vertical scan. It charges up to about 90v just prior to flyback. This assists in a rapid flyback, but also keeps Q302 collector voltage closer to 44V during most of the first 1/3 of the scan.

At flyback, Q302 conducts causing the flyback voltage spike to initially be equal to about 90V. This assists rapid vertical flyback. The flyback duration is about 0.885 ms.

After flyback however, due to the fact Q302 is sourcing current to the initial part of the vertical scan, C314 unfortunately keeps discharging until the collector-emitter voltage of Q302 becomes near equal (which should not be allowed as the transistor goes into a non linear mode) This causes a small glitch in the scanning current, resulting in the scan line pairing and apparent white line on the screen. It becomes a "focal vertical linearity defect".

The problem is solved by increasing the value of C313 from 0.018uF to 0.039uF. This couples extra charge during the charging time, from the H pulses into C314. It attempts to charge C314 to a value higher than the 115V power rail, so as a result D306 conducts. But, as can be seen, this change prevents the collector-emitter voltage of Q302 falling too low, and so solves the problem, eliminating the focal linearity defect:

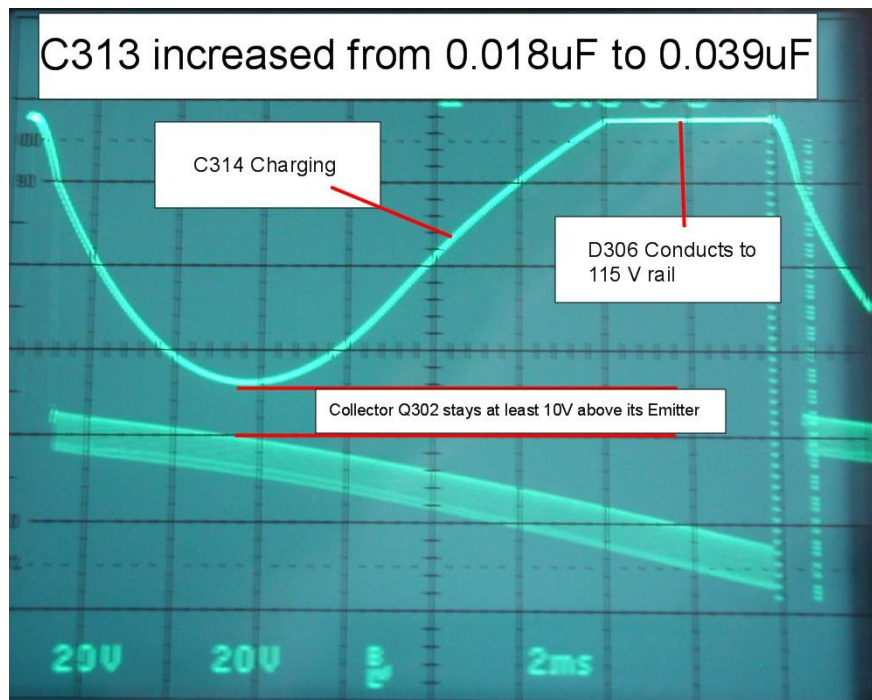

(One other thing for those wondering, the reason why the output voltage from the vertical amplifier to the yoke looks like a thick band, rather than a thin line, is the horizontal scanning currents have some crosstalk to the vertical coils in the actual deflection yoke assembly).

If you decide to replace C313 (the 0.018uF capacitor) with a 0.039uF one, to eliminate this defect, make sure it is rated at 250V or higher.
