

IBM PCjr Color Display Installation and Operating Instructions

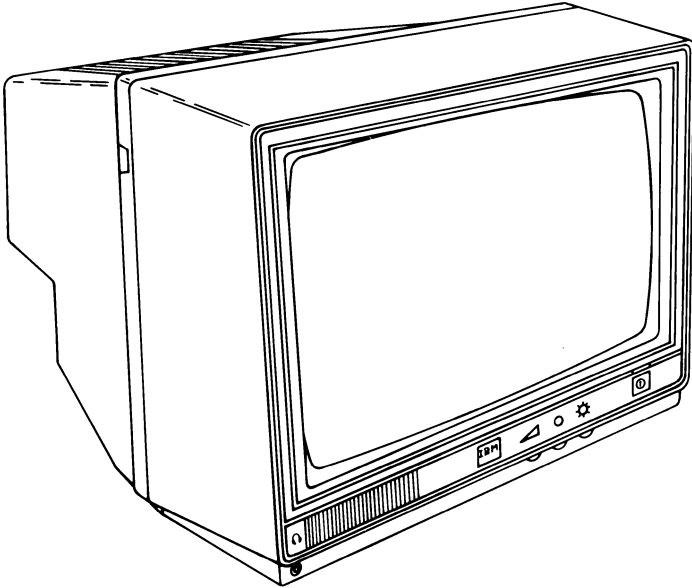

If your IBM PCjr has not been set up at this time, do so before installing this option.

This option consists of the following:

- IBM PCjr Color Display
- Power Cord
- Signal Cable

If any of these items are missing or damaged, notify your place of purchase.

LIMITED WARRANTY

The International Business Machines Corporation warrants this IBM Personal Computer Product to be in good working order for a period of one year from the date of purchase from IBM or an authorized IBM Personal Computer Dealer. Should this Product fail to be in good working order at any time during this one year warranty period, IBM will, at its option, repair or replace this Product at no additional charge except as set forth below. Repair parts and replacement Products will be furnished on an exchange basis and will be either reconditioned or new. All replaced parts and Products become the property of IBM. This limited warranty does not include service to repair damage to the Product resulting from accident, disaster, misuse, abuse, or non-IBM modification of the Product.

Limited Warranty service may be obtained by delivering the Product during the one year warranty period to an authorized IBM Personal Computer Dealer or any IBM Service/Exchange Center and providing proof of purchase date. If this Product is delivered by mail, you agree to insure the Product or assume the risk of loss or damage in transit, to prepay shipping charges to the warranty service location and to use the original shipping container or equivalent. Contact an Authorized IBM Personal Computer Dealer or write to IBM Personal Computer, Sales and Service, P.O. Box 1328-W, Boca Raton, Florida 33432, for further information.

ALL EXPRESS AND IMPLIED WARRANTIES FOR THIS PRODUCT, INCLUDING THE WARRANTIES OF MERCHANTABILITY AND FITNESS FOR A PARTICULAR PURPOSE, ARE LIMITED IN DURATION TO A PERIOD OF ONE YEAR FROM THE DATE OF PURCHASE, AND NO WARRANTIES, WHETHER EXPRESS OR IMPLIED, WILL APPLY AFTER THIS PERIOD. SOME STATES DO NOT ALLOW LIMITATIONS ON HOW LONG AN IMPLIED WARRANTY LASTS, SO THE ABOVE LIMITATIONS MAY NOT APPLY TO YOU.

IF THIS PRODUCT IS NOT IN GOOD WORKING ORDER AS WARRANTED ABOVE, YOUR SOLE REMEDY SHALL BE REPAIR OR REPLACEMENT AS PROVIDED ABOVE. IN NO EVENT WILL IBM BE LIABLE TO YOU FOR ANY DAMAGES, INCLUDING ANY LOST PROFITS, LOST SAVINGS OR OTHER INCIDENTAL OR CONSEQUENTIAL DAMAGES ARISING OUT OF THE USE OF OR INABILITY TO USE SUCH PRODUCT, EVEN IF IBM OR AN AUTHORIZED IBM PERSONAL COMPUTER DEALER HAS BEEN ADVISED OF THE POSSIBILITY OF SUCH DAMAGES, OR FOR ANY CLAIM BY ANY OTHER PARTY.

SOME STATES DO NOT ALLOW THE EXCLUSION OR LIMITATION OF INCIDENTAL OR CONSEQUENTIAL DAMAGES FOR CONSUMER PRODUCTS, SO THE ABOVE LIMITATIONS OR EXCLUSIONS MAY NOT APPLY TO YOU.

THIS WARRANTY GIVES YOU SPECIFIC LEGAL RIGHTS, AND YOU MAY ALSO HAVE OTHER RIGHTS WHICH MAY VARY FROM STATE TO STATE.

FOR WARRANTY SERVICE OR ASSISTANCE IT IS RECOMMENDED THAT THIS PRODUCT BE RETURNED TO THE AUTHORIZED IBM PERSONAL COMPUTER DEALER FROM WHOM IT WAS PURCHASED OR TO ANY IBM SERVICE/EXCHANGE CENTER.

FEDERAL COMMUNICATIONS COMMISSION RADIO FREQUENCY INTERFERENCE STATEMENT

Warning: This equipment has been certified to comply with the limits for a Class B computing device, pursuant to Subpart J of Part 15 of FCC rules. Only peripherals (computer input/output devices, terminals, printers, etc.) certified to comply with the Class B limits may be attached to this computer. Operation with non-certified peripherals is likely to result in interference to radio and TV reception.

INSTRUCTIONS TO USER

This equipment generates and uses radio frequency energy and if not installed and used properly, i.e., in strict accordance with the operating instructions, reference manuals, and the service manual, may cause interference to radio or television reception. It has been tested and found to comply with the limits for a Class B computing device pursuant to Subpart J of Part 15 of FCC Rules, which are designed to provide reasonable protection against such interference when operated in a residential installation.

If this equipment does cause interference to radio or television reception, which can be determined by turning the equipment off and on, the user is encouraged to try to correct the interference by one or more of the following measures:

- Reorient the receiving antenna.
- Relocate the equipment with respect to the receiver.
- Move the equipment away from the receiver.
- Plug the equipment into a different outlet so that equipment and receiver are on different branch circuits.
- Ensure that side option mounting screws, attachment connector screws, and ground wires are tightly secured.
- If peripherals not offered by IBM are used with this equipment, it is suggested that you use shielded, grounded cables with in-line filters, if necessary.

If necessary, consult your dealer service representative for additional suggestions.

The manufacturer is not responsible for any radio or TV interference caused by unauthorized modifications to this equipment. It is the responsibility of the user to correct such interference.

CAUTION

This product is equipped with a line cord and plug designed for the user's safety. It is to be used with a properly grounded power receptacle to avoid possible electrical shock.

Contents

Installation Requirements	2
Tools Required	2
Installation Instructions	3
Operating Instructions	7
Controls	7
Earphone Jack	9
Tilt Stand	10
Adjustments	12
IBM PCjr Color Display Check Out Procedure ...	18
Service Information	33

Installation Requirements

Your IBM PCjr must be set up before you can install this option.

Tools Required

- none

Installation Instructions

- 1 Remove your IBM PCjr Color Display from the shipping carton. You may want to save the shipping carton for future use.

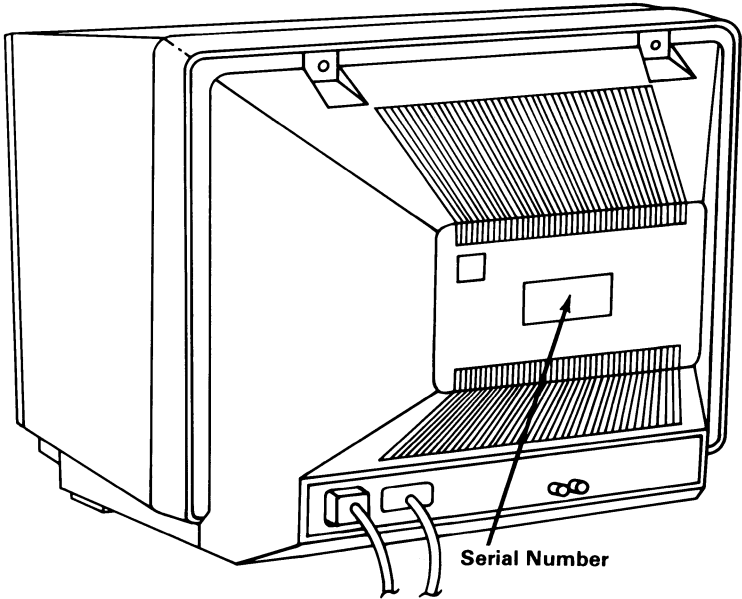

- 2 Record your IBM PCjr Color Display serial number here:

Serial Number _____

- 3 Turn your IBM PCjr power off.
- 4 If the display power cord is not attached, plug it into the back of your display.
- 5 Connect the display signal cable to the connector marked D on the rear of your IBM PCjr. The signal cable fits only one way.

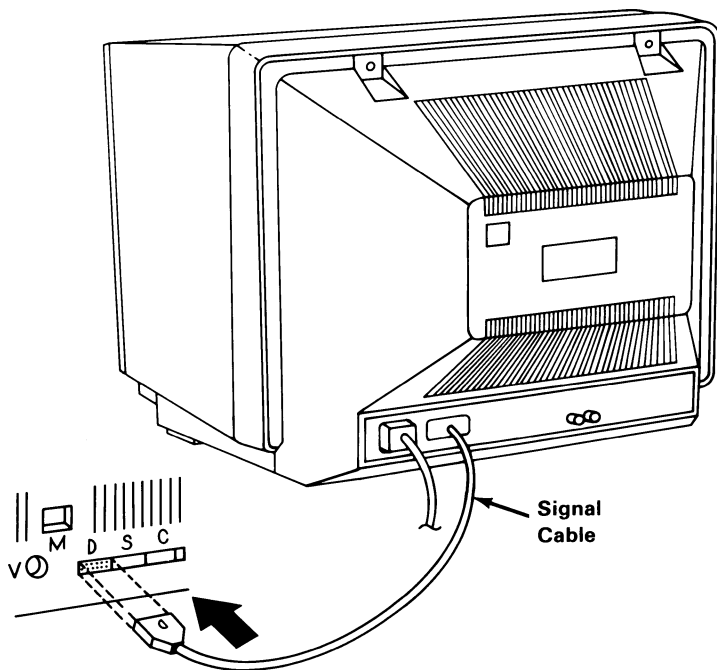

- 6** Plug the display power cord into a working electrical outlet.

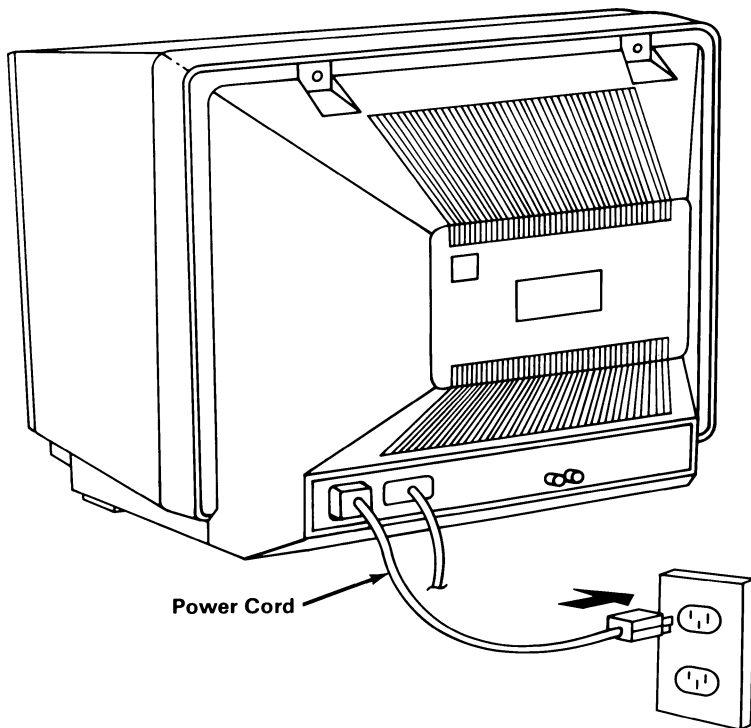

CAUTION: Connect to a properly grounded outlet

7 Your IBM PCjr Color Display is installed.

Important:

Insert these option instructions into Section 5 of the *Guide to Operations* manual.

8 If you have any other PCjr options to install, install them at this time.

If you do not have any other PCjr options to install, continue normal operation.

Note: If you have diskette errors while using the IBM PCjr Color Display, move the IBM PCjr Color Display away from your IBM PCjr.

Operating Instructions

Controls

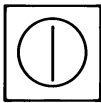
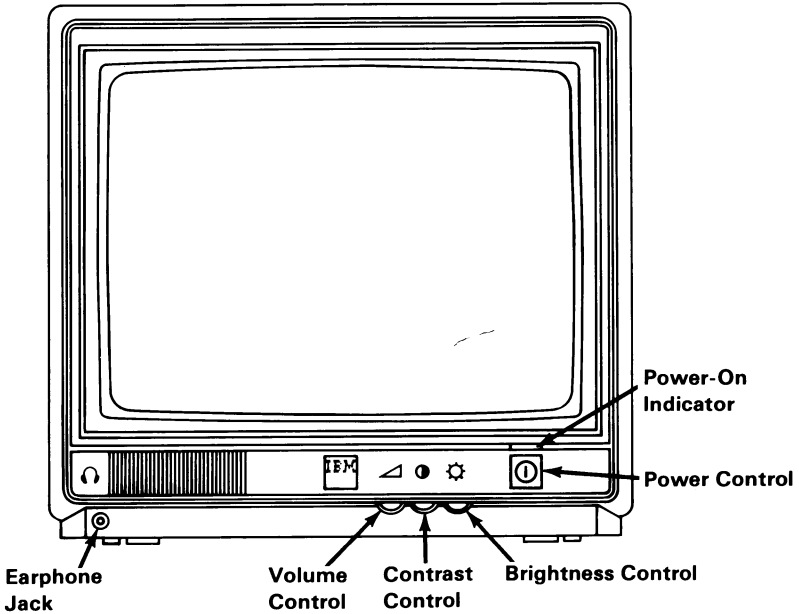

The Power control is a push button. Pushed once, the power is turned on. Pushed again, the power is turned off. The Power-on Indicator lights when the power is on.



The Brightness control increases screen brightness when turned clockwise and decreases screen brightness when turned counterclockwise.



The Contrast control changes the brightness of some colors when you compare them to other colors on the screen. When the Contrast control is turned clockwise some colors get brighter. When the Contrast control is turned counterclockwise some colors get darker.



The Volume control increases the sound volume from the display speaker when turned clockwise, and decreases the sound volume when turned counterclockwise.



Earphone Jack

The Earphone Jack is on the front of the display. When an earphone is plugged into the Earphone Jack, the display speaker is disconnected.

The Earphone Jack has an output impedance of 100 ohms and accepts a standard 3.5 millimeter monophonic plug.

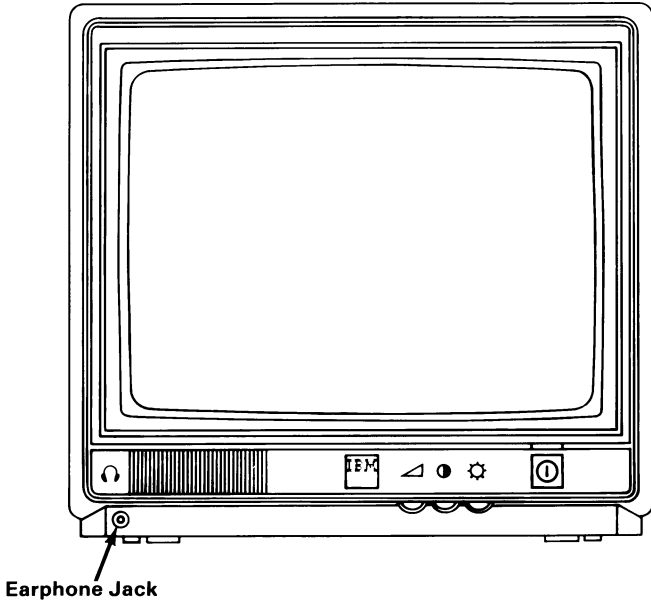

Tilt Stand

The Tilt Stand is used to adjust your display to a comfortable viewing position. There are three tilt positions: no tilt, half tilt, and full tilt. To use the stand, do the following:

- 1** Turn the display power off.
- 2** Make sure there is 304 mm (12 in.) of clear workspace behind the display.
- 3** Lift the front of the display up until the display rests on its back.

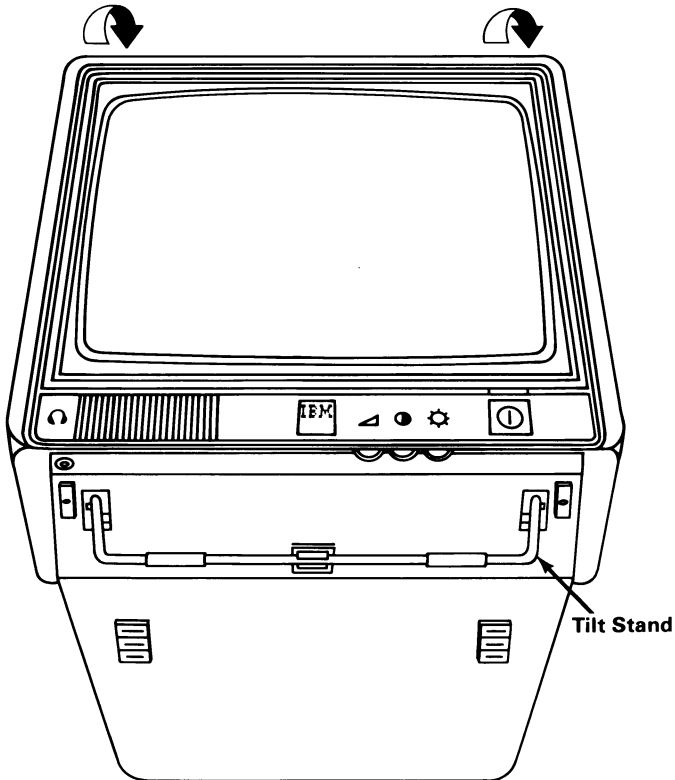

- 4** Move the Tilt Stand into one of its positions.

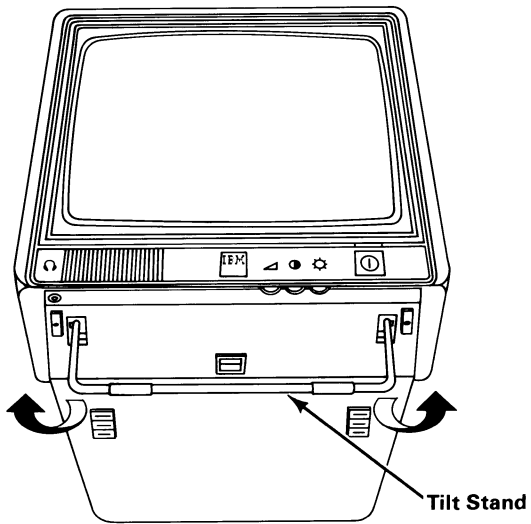

- 5** Return the display back to the viewing position.

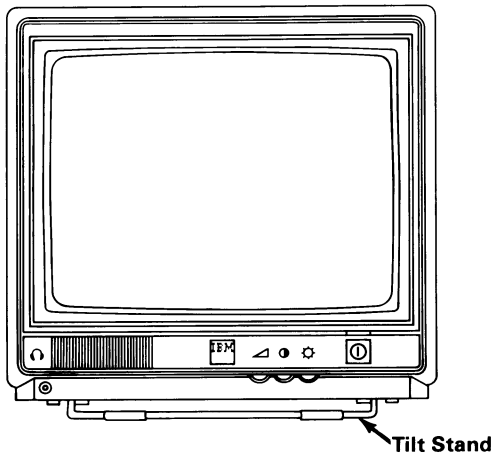

Adjustments

Vertical Hold Adjustment

Use this adjustment only if the IBM PCjr Color Display has a vertical hold problem (screen rolling top-to-bottom or bottom-to-top).

- 1** Turn the display power on. Do not turn the PCjr power on.
- 2** Turn the Brightness and Contrast controls fully clockwise.

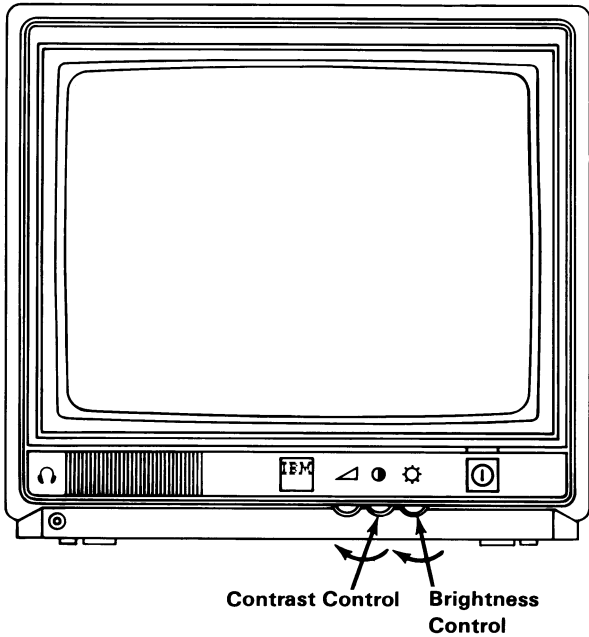

- 3** Remove any cartridges or diskettes from your IBM PCjr.
- 4** Turn your IBM PCjr power on.

- 5 When the IBM PCjr BASIC Message Screen appears, turn the Vertical Hold control fully clockwise.

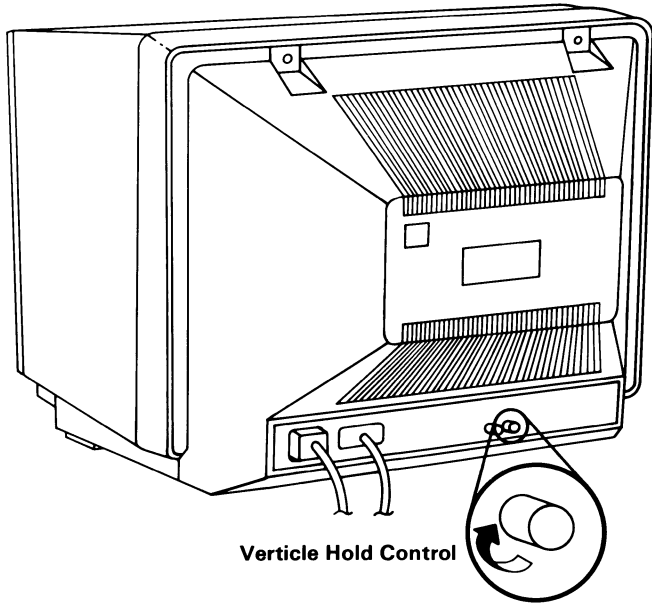

- 6 Turn the Vertical Hold control counterclockwise until the screen stops rolling and is stable.

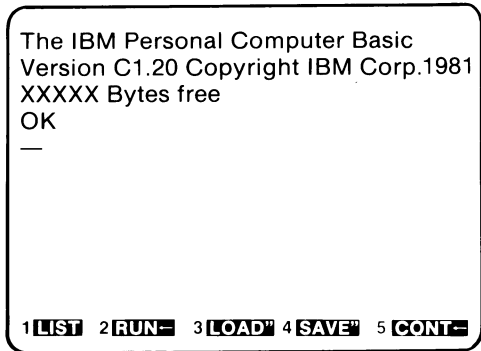

- 7 Adjust the Brightness and Contrast controls to a comfortable level.

Vertical Size Adjustment

Use this adjustment only if the height of the figures on the screen is wrong.

- 1** Turn your display power on. Do not turn the PCjr power on.
- 2** Turn the Brightness and Contrast controls fully clockwise.

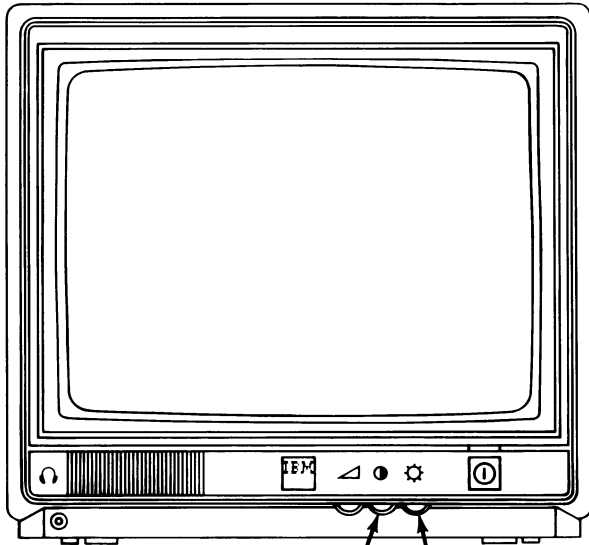

Contrast Control Brightness Control

- 3 Remove any cartridges or diskettes from your IBM PCjr.
- 4 Turn your IBM PCjr power on.
- 5 When the IBM PCjr BASIC Message Screen appears, press the Esc key. The following screen appears.

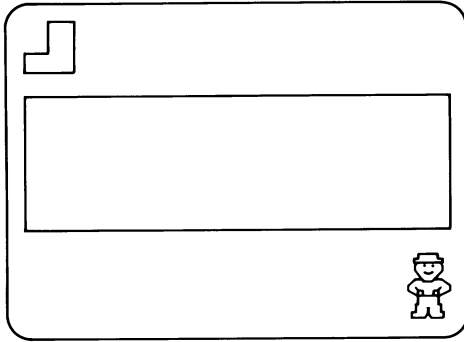

- 6** Turn the Vertical Size control fully counterclockwise.

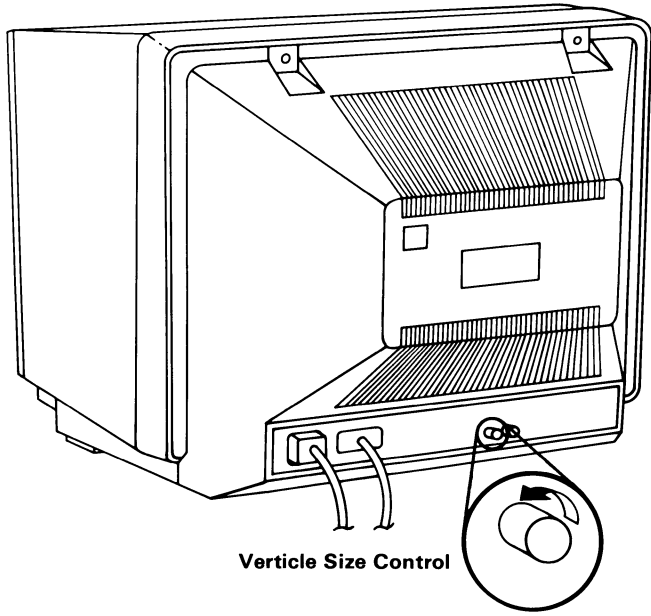

- 7** Black areas appear at the top and bottom of the screen.

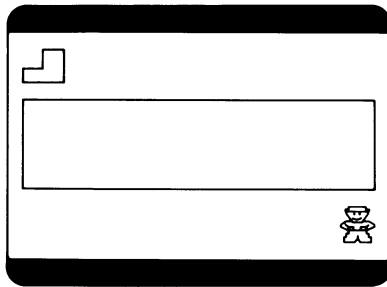

- 8** Turn the Vertical Size control clockwise until the black areas disappear from the top and bottom of the screen. One of the black areas may disappear before the other one. Continue turning until both black areas disappear.

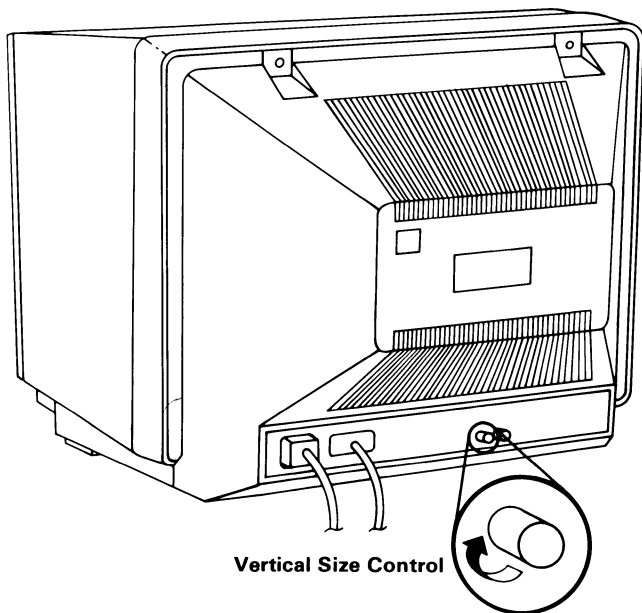

- 9** Adjust the Brightness and Contrast controls to a comfortable level.
- 10** Press and hold the Ctrl and Alt keys and then press the Del key. Continue with normal operations.

IBM PCjr Color Display Check Out Procedure

Use the IBM PCjr Color Display Check Out Procedure to make sure your IBM PCjr Color Display operates correctly.

If your display needs to be serviced, return it with the power cord.

- 1 Turn your display power on.
- 2 Is the Power-on indicator lit?

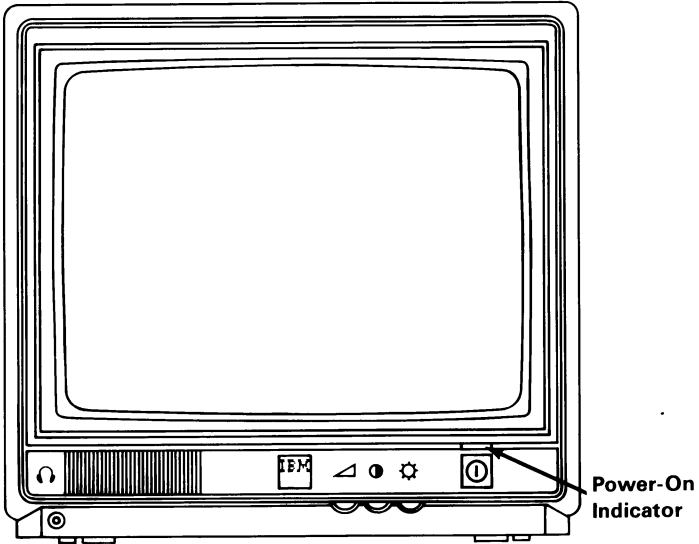

YES - Go to Step 3.

NO - See if the power cord is plugged into a working electrical outlet and into the rear of the display. If it is, have your display serviced. See "Service Information" in this section.

- 3 Turn your IBM PCjr power off.
- 4 Turn the Brightness and Contrast controls fully clockwise.

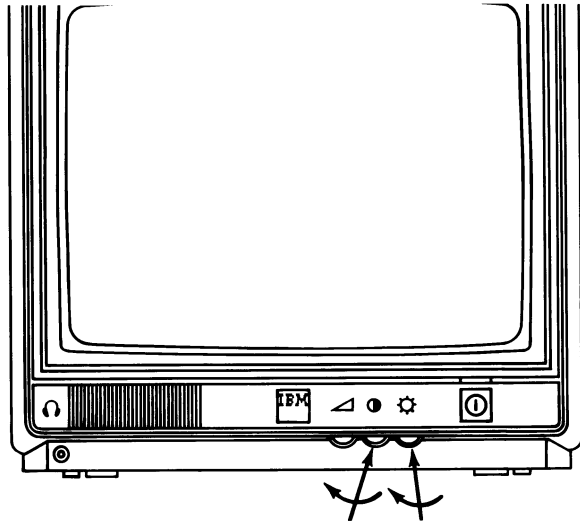

Contrast Control Brightness Control

- 5 Turn the Vertical Size control fully counterclockwise. Black areas should appear at the top and bottom of the screen.

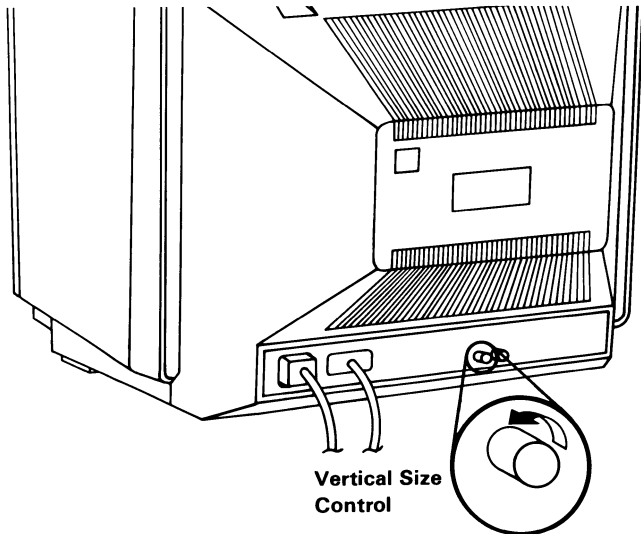

Vertical Size
Control

- 6** Do black areas appear at the top and bottom of the screen?



- YES** - Go to Step 7.
- NO** - Have your display serviced. See "Service Information" in this section.

7

Are the black areas at the top and bottom of the screen about the same size?

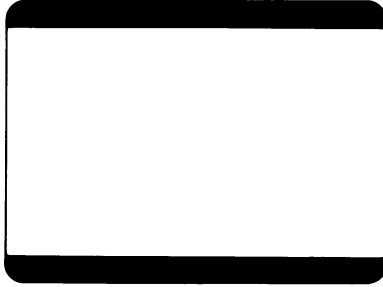

YES - Go to Step 8.

NO - Have your display serviced. See "Service Information" in this section.

- 8** Turn the Vertical Size control clockwise until the black areas at the top and bottom of the screen just disappear. If one of the black areas disappears before the other, continue to turn the control until the second black area is gone.

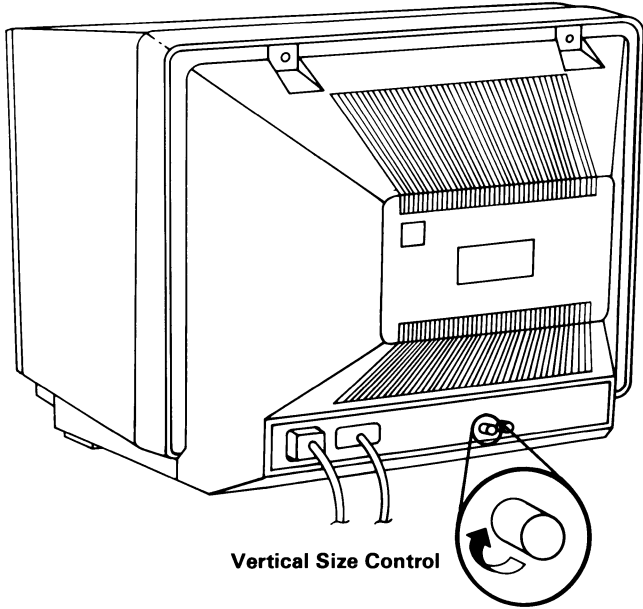

9 Is the screen white?

YES - Go to Step 15.

NO - Go to Step 10.

10 Turn your display power off.

11 Turn your IBM PCjr power off.

- 12** Disconnect the display signal cable from the rear of your IBM PCjr.

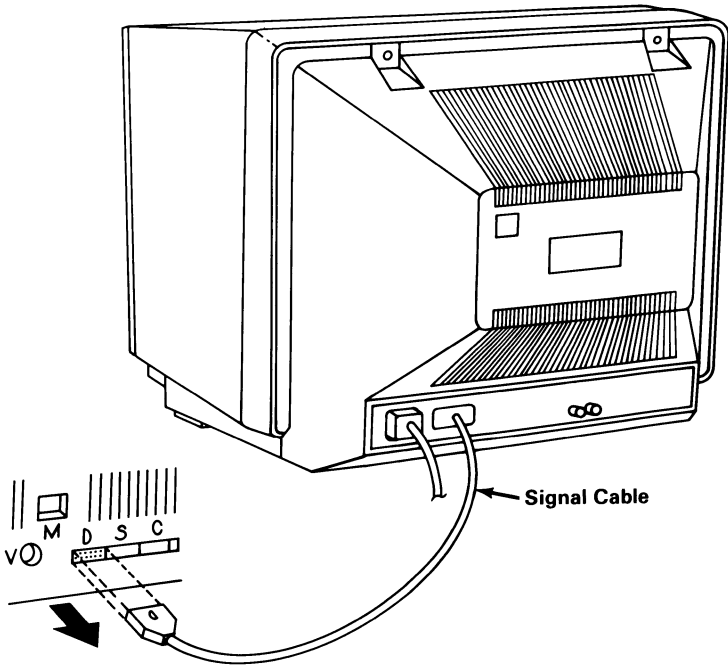

- 13** Turn your display power on.

- 14** Is the screen white?

YES - Have your IBM PCjr serviced. See "Service Information" in this section.

NO - Have your display serviced. See "Service Information" in this section.

- 15** While watching the screen, turn your IBM PCjr power on.
- 16** Did the screen change from white to black as soon as you turned your IBM PCjr power on? (This totally black condition may last only a few seconds. Then the IBM Color Bar screen appears followed by the IBM Personal Computer BASIC Message Screen.)

YES - Go to Step 17.

NO - Have your display serviced. See "Service Information" in this section.

- 17** Wait for your IBM PCjr to finish testing itself. The IBM Personal Computer BASIC Message Screen appears with a blinking cursor.

- 18** Did the IBM Personal Computer BASIC Message Screen appear?

YES - Go to Step 19.

NO - Have your IBM PCjr serviced. See "Service Information" in this section.

19 Is the screen stable?

YES - Go to Step 22.

NO - Go to Step 20.

20 Turn the Vertical Hold control clockwise as far as it will go. Then, turn it counterclockwise until the screen stops rolling and is stable.

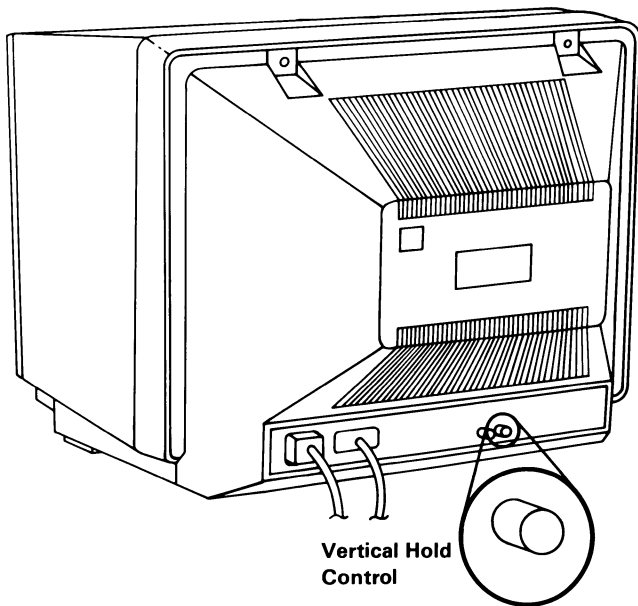

21 Were you able to make the screen stable?

YES - Go to Step 22.

NO - Have your display serviced. See "Service Information" in this section.

22 Does the screen have white characters on a dark background?

YES - Go to Step 28.

NO - Go to Step 23.

23 Turn your IBM PCjr power off.

24 Turn your display power off.

25 Disconnect the display signal cable from the rear of your IBM PCjr.

26 Turn your display power on.

27 Is the screen white?

YES - Have your IBM PCjr serviced. See "Service Information" in this section.

NO - Have your display serviced. See "Service Information" in this section.

28 Turn the Brightness control fully counterclockwise.

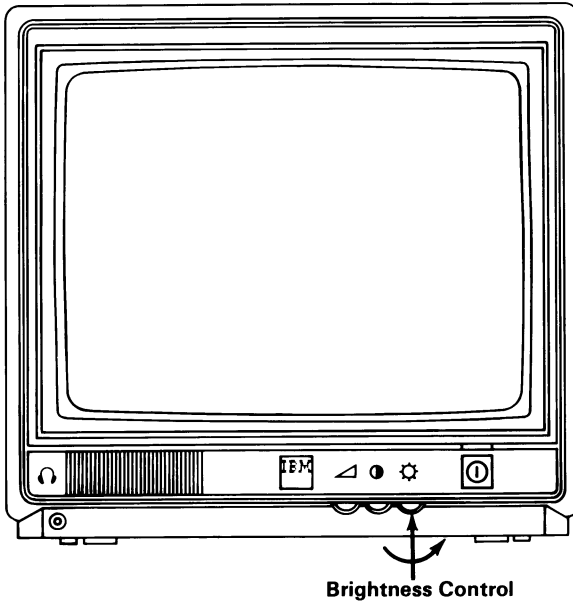

29 Did the characters get darker?

YES - Go to Step 30.

NO - Have your display serviced. See "Service Information" in this section.

- 30** Turn the Brightness control fully clockwise.

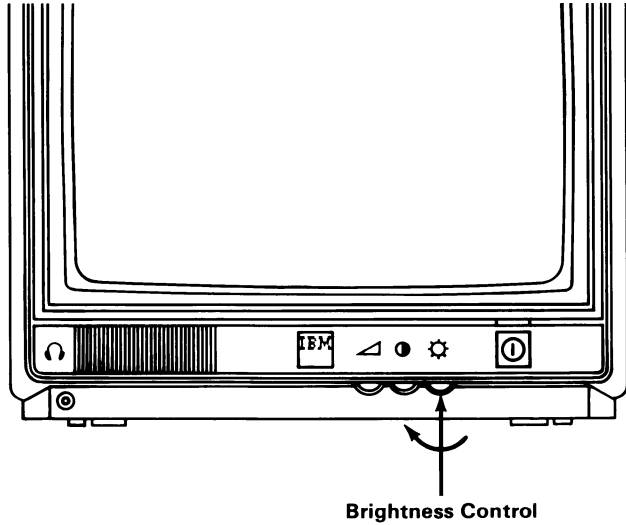

- 31** Turn the Contrast control fully counterclockwise. Did the characters get darker?

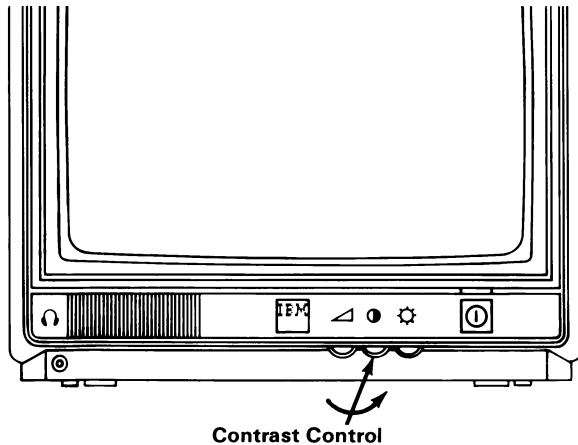

YES - Go to Step 32 .

NO - Have your display serviced. See "Service Information" in this section.

32 Turn the Contrast control fully clockwise.

33 Do you have any of the problems shown in the examples below?

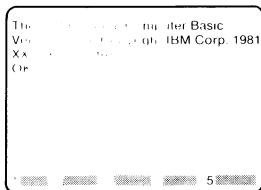

Too Dim



Too Wide

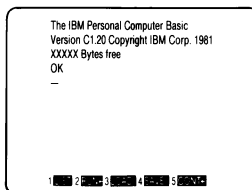

Too Narrow

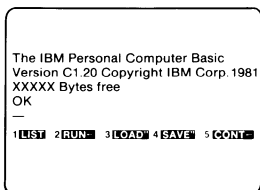

Too Short

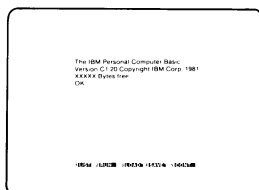

Shrunken

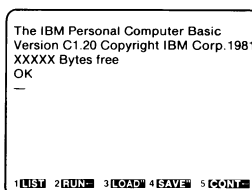

Characters Shifted Left or Right or Up and Down Off the Display Area

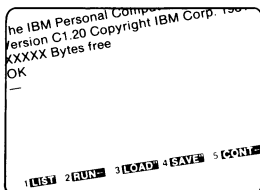

Tilted

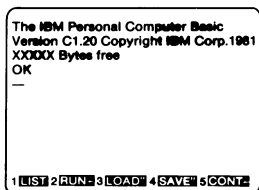

Out of Focus

YES - Have your display serviced. See "Service Information" in this section.

NO - Go to Step 34.

- 34 Adjust the Brightness and Contrast controls to a comfortable level.
- 35 Turn your IBM PCjr and display power off.
- 36 Disconnect the display signal cable from the rear of your IBM PCjr.

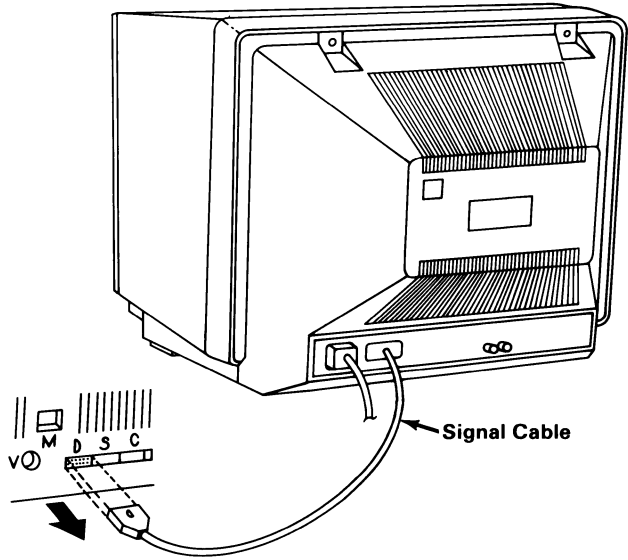

- 37** Turn the Volume control fully clockwise.

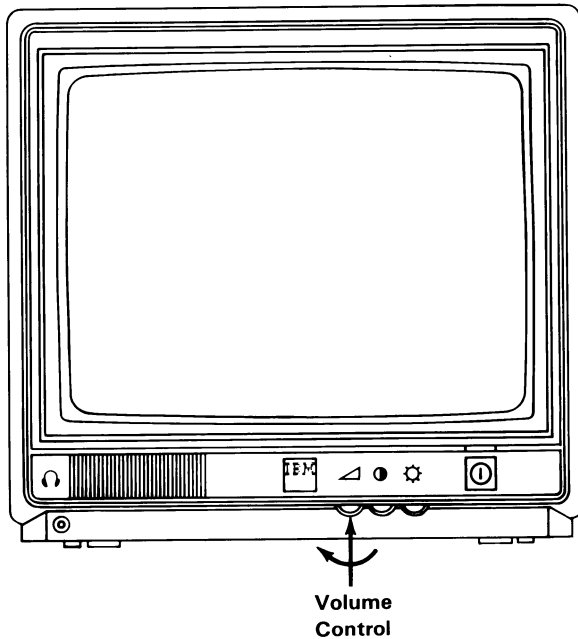

- 38** Turn your display power on.
- 39** Do you hear a constant hum from your display?
- YES -** Your display is working correctly. If you are having a sound problem while using your IBM PCjr, have your IBM PCjr serviced. See "Service Information" in this section.
- NO -** Have your display serviced. See "Service Information" in this section.

Service Information

If your IBM PCjr or IBM PCjr Color Display has a problem and must be serviced, do the following:

- 1** Turn your IBM PCjr, IBM PCjr Color Display, and all attachments off.
- 2** Unplug your IBM PCjr and IBM PCjr Color Display power cords from their electrical outlets.
- 3** Don't forget that the power cord, keyboard, and all side-attached options are considered part of the IBM PCjr, so you need to keep them with the system unit. You should also keep any cartridges or diskettes that were being used when the failure occurred with the IBM PCjr.
- 4** Call your place of purchase for specific instructions before bringing in your IBM PCjr or IBM PCjr Color Display.





