

Users Manual

BREAKthru 286



Personal Computer Support Group

Users Manual
Breakthru 286

*Exceptional speedup card
for the IBM PC, XT, COMPAQ
and most other clones.*

Personal Computer Support Group
4540 Beltway Drive
Dallas, TX 75244
1-214-404-4000

Money Back if not Satisfied.

At any time within sixty days from the date you purchased your Breakthru 286 you can return it for a full refund of your purchase price. Please ship it in accordance with the instructions below.

Limited Warranty.

PCSG, Inc. warrants its products to be in working order for a period of one year from the date of purchase. Should a PCSG hardware product fail to be in working order during this period PCSG will repair or replace that product at its option at no charge except as set forth below.

This warranty does not include service to the product to repair damage resulting from accident, misuse, disaster or modifications made to the product by non-PCSG persons.

All express and implied warranties for this product are limited in duration to a period of one year from the date of purchase, and no warranties, whether express or implied will apply after this period.

If this product is not in good working order as warranted above your sole remedy shall be repair or replacement as provided above.

In no event will PCSG, Inc be liable to you for any damages, including lost profits, lost savings or any other incidental or consequential damages arising out of the use of or inability to use such product, even if PCSG or a PCSG representative has been advised of the possibility of such damages, or for any claim by any other party.

If you do not accept the terms of this warranty, please return the product immediately for a full refund.

This warranty gives you specific legal rights, and you may also have other rights which may vary from state to state.

Shipping Instructions.

Deliver the product with a copy of the original invoice to:

Personal Computer Support Group, Inc.
11035 Harry Hines #206
Dallas, Texas 75229

You are responsible for the cost of shipping, and for loss or damage in shipment, so we recommend that you insure it.

Turbo motherboards.

A conflict exists between some turbo motherboards and the software switching of the Breakthru 286. It can be compensated for by careful setting of the * jumper.

If the turbo motherboard can switch between fast and slow with a hot key, and it uses the same technique to switch speeds as does Breakthru, it may accidentally switch the Breakthru speed. This will usually crash Breakthru, since a Breakthru speed switch can only be properly done by the BSS or Lightning software. There are many ways around this which will be outlined below, but bear in mind that the problem is caused by the motherboard switching speeds, which can happen automatically at boot up, or when the hot key combination is pressed.

The problem will not arise if you disable Breakthru software speed switching by leaving the * jumper off altogether. But this may cause problems for you accessing your floppy disk if you desire to cache your BIOS (R jumper on), and may sometimes stop your computer booting.

If you allow Breakthru Speed Switching, but power up not caching, (*jumper vertical), your computer will almost certainly crash at some point in the boot up sequence when the motherboard accidentally enables the Breakthru caching but does it wrong.

The alternative is to put the * jumper in the horizontal position, so that when the motherboard switches on caching, it is already on, and no harm is done. The drawback of this technique is that your computer may not boot properly in this configuration with the R jumper on, so you may have to forego BIOS caching.

In any case, best results are usually achieved by jumpering your motherboard to run at 8MHz, jumpering the Breakthru F/S jumper to F, and never trying to switch motherboard speeds with the motherboard hot key combination. Always speed switch with the Breakthru speed switch combination that you set in your CONFIG.SYS file with the BSS "key" command.

Breakthru 286 Manual Addendum

This note covers three topics; command line options for BSS.SYS, clock speeds for 80287 math coprocessors and more information about turbo motherboards.

Command line options for BSS.SYS.

You can switch on your caching at load time with BSS.SYS, and avoid having to use Lightning if you don't want to. This is done by putting the command

```
device = BSS.SYS cache on
```

in your CONFIG.SYS file. This is useful if you want to cache your BIOS (put the R jumper on), but your computer won't boot with the BIOS cached and caching on. Simply put the * jumper in the vertical position, so that speed switching is enabled and the computer powers up slow. The above command will kick Breakthru into high speed to complete your boot. Put this command in front of any EMS device driver to avoid long waiting during power on self test.

You can define the "hot key" for speed switching from the keyboard without Lightning, too. The "KEY =" parameter will work with BSS.SYS just the same as it works with L.COM. See Appendix 7 for details. Sample "key" command with BSS.SYS:

```
device = BSS.SYS key = RC
```

Clock speeds for the 80287 coprocessor.

The 80287 math coprocessor can be run at two speeds. The two speeds available depend on how your computer is set up, but they are always:

1. The speed of the Breakthru 286
2. The speed of your system board.

On the 287 jumper of your Breakthru 286, the first setting is labelled 8 and the second setting is labelled 5. These would be the megahertz speeds on a regular PC and an 8 MHz Breakthru 286. If you have a turbo motherboard that runs at 8 MHz, the setting labelled 5 will run the 287 at 8 MHz. If you have a Breakthru 286-12, the setting labelled 8 will run the 287 at 12 MHz. It is important to buy a 287 that is rated at the speed you intend to run it, since unlike many chips, it is unlikely to work at a higher speed than rated.

Breakthru 286 Installation

How detailed do you need your instructions?

Use the set of instructions which suits your needs. Whether you are Expert, Experienced or Novice, we have instructions that will tell you what you need to know.

This manual is divided into three sections. Each section covers the same installation steps, but the second is more detailed than the first and the third is the most detailed and is illustrated.

Please take care.

By the way, the installation process is simple and virtually foolproof. But do be careful when plugging the cable and the 8087 blanking plug in. It is possible to bend the pins if they are not lined up perfectly.

Additional Documentation.

Please check the Lightning diskette included with this Breakthru 286 for a file called

EXTRA.DOC

If present, this file contains additional information not included in this manual. Just print it out or use the 'TYPE' DOS command to view it.

Compaq.

If you have a Compaq the installation steps are very different from those for a regular PC. Please turn to Appendix 4 for complete instructions.

Contents

Section 1	Quick View Guide
Section 2	Brief Explanation
Section 3	Detailed Instructions
Appendix 1	Special jumper settings
Appendix 2	How a cache works
Appendix 3	Unique features of Breakthru 286
Appendix 4	Installation on a Compaq
Appendix 5	Installation on other clones
Appendix 6	Compatibility with add-ons.
Appendix 7	Software Utilities

Section One

QUICK VIEW GUIDE

Simple Steps:

- 1. Turn computer off and remove cover.**
- 2. Remove the 8088 processor.**
- 3. Insert the math coprocessor dummy plug in the PC.**
- 4. Set the cache memory switches on Breakthru 286.**
- 5. If you have one, plug the 80287 math coprocessor into Breakthru 286.**
- 6. Install the Breakthru 286 in any slot and plug the cable into the vacant 8088 socket.**
- 7. Replace the cover on the computer and power up.**

Section Two

Explanation of the Quick View steps.

This is section two. The third section of this manual has even more detailed explanations of each step, along with illustrations.

- 1. Remove the cover.**
 - a. Turn the computer off.
 - b. Unplug the power cord.
 - c. Unscrew the computer cover and carefully pull forward then lift the front to remove.

- 2. Locate and remove the 8088 processor.**
 - a. Using the tool provided, carefully pry the processor from its socket, lifting both ends evenly.
 - b. Check that no pins are bent or broken and store the 8088 safely for later use.

- 3. Insert the dummy plug into the 8087 math coprocessor socket.**
 - a. If an 8087 math coprocessor is present, remove it by gently lifting it with the hooked tool provided and store it safely with the 8088.
 - b. Place the dummy plug provided in the coprocessor socket. Ensure that pin one is to the left. Pin one is by the embossed triangle.

4. **Set the cache memory switches on Breakthru 286.**
 - a. Use the chart in section 3 to determine the correct setting for your memory allowance.
 - b. ON position covers both pins in a row; OFF leaves one pin uncovered.

5. **Plug the 80287 coprocessor into Breakthru 286.**

This step is not necessary if you do not have a 287 processor.

- a. Set the JMP3 jumper to the 80287 chip's clock speed (5 or 8MHz).
- b. Carefully press the 80287 math coprocessor into the socket at the top of the board, notched end to the left.

6. **Install Breakthru 286 and cable.**

- a. Choose an expansion slot near the 8088 socket. Remove and save the screw and bracket.
- b. Push the cable plug into the vacant 8088 socket. This is the most critical step. The first thing to suspect if the board fails to work is a bent pin on this connector due to careless installation.
- c. Slide bottom edge of Breakthru 286 card into expansion slot and secure bracket with screw.

7. **Replace computer cover and connect power.**

Don't forget to reconnect the keyboard and display as well.

Section Three - Detailed Installation Instructions

It is easy! Follow these step-by-step instructions and give your computer superior speed-up capabilities.

Step 1. Turn computer off and remove cover.

- a. Turn your computer off.
- b. Disconnect the power cord, and unplug the keyboard and display unit.
- c. Remove the screws securing the computer cover as shown in Illustration #1. Release the cover from the spring closures with a sharp tap with the heel of your hand, then gently pull the cover forward and swing up the front to remove. Set cover and screws aside in a safe place. Note that there is a little screw lug at the center of the back of the cover. Take care not to snag this on any internal cables that may be running over the tops of your expansion boards. This lug will catch on the front panel of the computer, which is why you must swing up the front of the cover in order to completely disengage it.

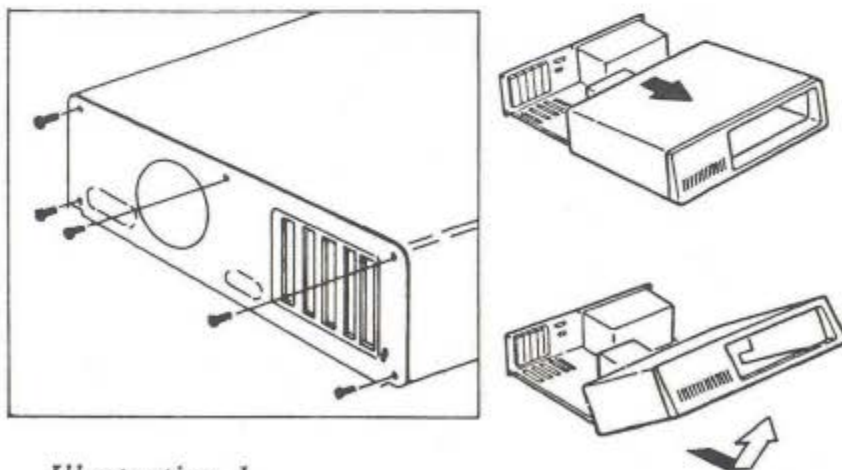

Illustration 1

Step 2. Remove the 8088 processor.

- a. Now that the cover has been removed, look inside the back of the exposed computer. You may wish to use an additional source of light to see more clearly inside.
- b. Use Illustration 2 as a guide to help you locate the expansion slots, the 8088 processor socket, and the 8087 math coprocessor socket. These are the components that you will need to familiarize yourself with to install Break-thru 286.
- c. Using the chip pulling tool that we have provided, carefully lift one end of the 8088 processor chip then the other to loosen it. Make sure that you lever both ends evenly, working back and forth until the chip is free.
- d. Check that no pins are bent or broken and store on an anti-static foam pad for possible later use.

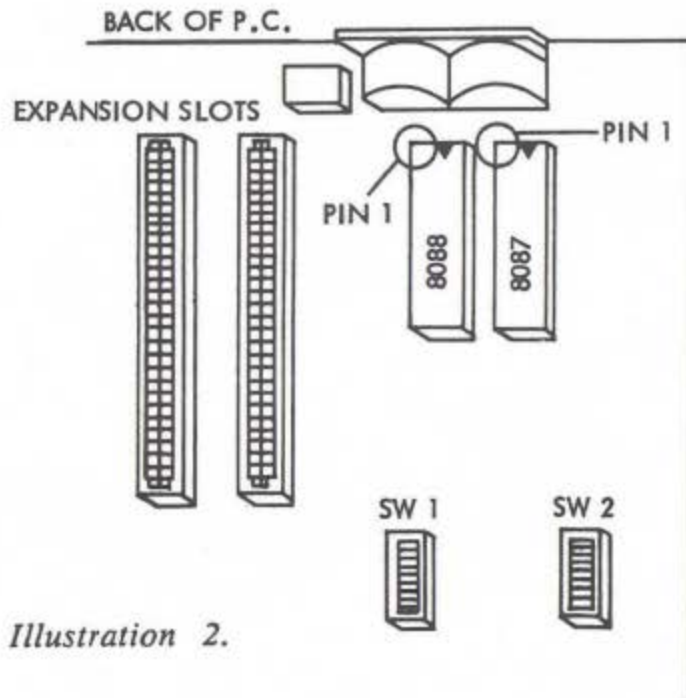

Illustration 2.

Step 3. Insert coprocessor dummy plug in the PC.

- a. On some PC's there will be an 8087 math coprocessor installed to the right of the 8088 socket. If present, it must be removed:
 - i. With the chip pulling tool that we have provided, carefully remove the 8087 chip the same way you did the 8088 in step 2 above.
 - ii. Store the chip on the anti-static foam pad with the 8088 processor.
- d. Push the dummy plug that we provide into the now empty 8087 socket. Be careful to put the pin 1 end in the right orientation. On a regular IBM PC or XT this is toward the back of the computer. You can recognise pin 1 by the embossed triangle. Also be very careful that each leg of the plug is aligned exactly over the socket it is to go in before you press it home. The commonest problem in the installation of devices like this is bent pins due to missing the holes.
- e. If you had an 8087 but you don't have a 287, or if you didn't have an 8087 but you do have a 287 you will need to reset the math coprocessor switch on the motherboard. This is switch 2 on switch block 1 (SW1). Set this switch ON if you DON'T have a 287. If you DO have a 287, set this switch to OFF. See Illustration 2 for the location of SW1.

Step 4. Set the jumpers on Breakthru 286.

This section deals with two jumper blocks, one at the top left of the board labelled JMP1, and one half way down the right hand side of the board by the metal mounting bracket labelled FS.

- a. Breakthru 286 has five jumper clips on five pairs of pins at the top left of the board

labeled JMP1. You must set three of these clips to indicate the total amount of your system memory. The other two clips deal with caching the BIOS ROM and software speed switching. The FS jumper pins on the right of the board are only of concern to you if you have a 'turbo clone' that runs at 8MHz. Here are the settings for the system memory jumpers; the settings for the other jumpers are discussed in detail in Appendix 1.

TOP LEFT CORNER OF BREAKTHRU 286

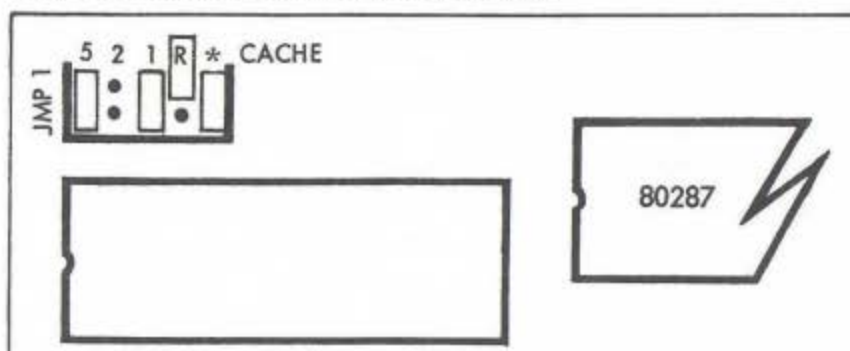

Illustration 3

5	2	1	R	*	
off	off	off	-	-	no memory cached
off	off	on	-	-	128K cached
off	on	off	-	-	256K cached
off	on	on	-	-	384K cached
on	off	off	-	-	512K cached
on	off	on	-	-	640K cached
-	-	-	on	-	BIOS ROM cached
-	-	-	-	horiz	Cache on at power up
-	-	-	-	vert	Cache off at power up
-	-	-	-	off	No software switch

See Appendix 1 for an explanation of R and *

- b. Use this chart to determine the right settings for your memory size. Remember to include both system memory and any additional expansion memory boards, but not any EMS 'above board' memory.
- c. Set your clips as specified on the chart. ON

means the clip connects the two pins in a pair. OFF means the clip is positioned to one side so the pins are not connected. We recommend that you do not completely remove any clips. While they may be in the OFF position, you may need to change them in the future due to changes in amount of memory.

Step 5. If you have one, plug the 80287 math coprocessor into Breakthru 286.

- a. Locate the 80287 socket and the JMP3 switch on Breakthru 286 as shown in Illustration 4.
- b. Look at your 80287 chip. If 80287-3 is printed on top, set the JMP3 clip to connect the bottom two pins (5Mhz). If 80287 is printed on top of the chip, set the JMP3 clip to connect the top two pins (8MHz).
- c. Carefully press the 80287 math coprocessor into the socket provided (see Illustration 4) with its indented end to the left.

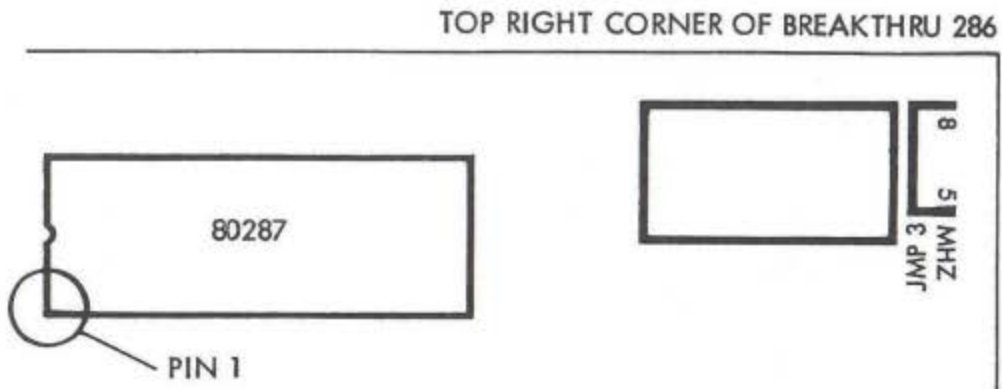

Illustration 4

Step 6. Install Breakthru 286 and cable.

- a. Connect the Breakthru 286 cable to the 8088 socket as shown in Illustration 5. Ensure that the pins are carefully aligned before you press the plug home. The commonest problem encountered when installing plugs of this kind is bent or broken pins due to misalignment.
- b. Choose an expansion slot near the 8088 socket for installing Breakthru 286. Breakthru 286 is a half slot card so you don't even have to give up a full slot. Remove the screw and mounting bracket from the chosen slot and set them aside.
- c. With the Breakthru 286 mounting bracket facing towards the back of the system unit, insert the connecting bottom edge of Breakthru 286 into the expansion slot (see Illustration 5). Secure its bracket with the screw removed earlier.

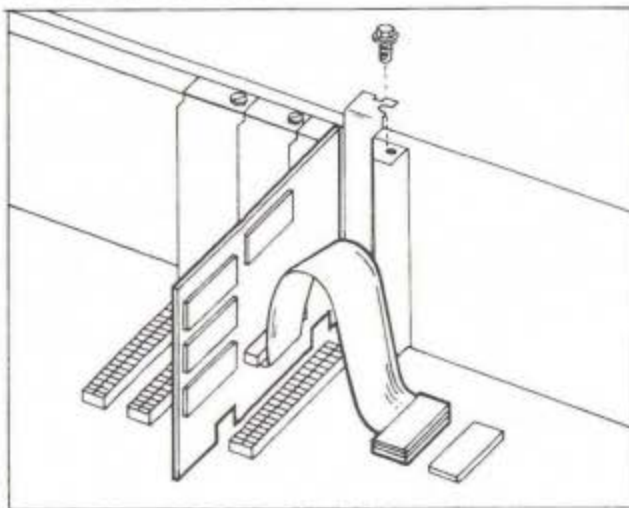

Illustration 5

Step 7. Replace cover and connect power.

Replace your computer's cover and reconnect the power cord, keyboard, and display unit. Breakthru 286 is now installed and ready to run.

Appendix 1 - The * , R and FS jumpers.

Additional jumpers on the Breakthru 286.

The * and R jumpers are in the top left corner of the board, in the same jumper block as the main memory size jumpers.

The * jumper sets the software speed switching. Software speed switching requires the use of Lightning to switch it on and off. There are three positions for this jumper:

- horizontal - connecting the top two pins at the right of JMP1
- vertical - connecting the rightmost pair of pins of JMP1
- off - not connecting any pins

As shipped to you, the "*" jumper is horizontal. This makes the Breakthru 286 power up going at full speed, and it makes it possible for software such as Lightning to switch the speed of the Breakthru 286 for compatibility with speed sensitive software and slow disk drives.

If you need to power up in slow (non caching) mode, you must put the "*" jumper in the vertical position. When you do this the Breakthru 286 first powers up in the slow mode, and must be switched into high speed with a command on the DOS command line. The command is:

L CACHE ON

This can be in your AUTOEXEC.BAT file or not, as you please. It will not load Lightning, so if you want to take advantage of Lightning disk speedup, you should still have a command in your AUTOEXEC.BAT

file such as:

L 1800 abx

which would reserve 1.8MB of your EMS memory for disk caching - see Appendix 7.

Leaving the "*" jumper off altogether will cause the software speed switching to not work at all, the Breakthru 286 will run at full speed under all circumstances. This is for compatibility with computers which conflict with the method Breakthru uses to switch speeds in software.

The R jumper enables caching of the ROM BIOS area (E0000H to FFFFFH). Switching it on increases the speed of screen updates by up to 30%. It has an even more dramatic effect on interpreted BASIC programs. Unfortunately, with the BIOS ROM cached, the power on self test fails, and the computer will not start up. For this reason, you cannot set the R jumper if you wish to power up caching. That is to say, you cannot have the * jumper horizontal, and the R jumper on. If you wish to cache the BIOS ROMs, you will need to put the * jumper in the vertical position, and enable caching with the Lightning command:

L cache on

in your AUTOEXEC.BAT file.

The F/S jumper is located half way down the edge of the Breakthru board right by the metal bracket. The S position is the standard one, for 4.77MHz motherboards such as the regular IBM PC and XT. The F position is for turbo motherboards which run at 8MHz.

NOTE: When EEMS boards that do backfilling in software are used, (JRAM uses a software program in CONFIG.SYS to do this) and this memory below 640K is not used for paging (unlike "DESQview" type multi-taskers) the "5","2","1" jumpers should be set to

reflect the amount of memory after backfilling
(typically 640K) and caching should initially be off
("**" jumper vertical).

Appendix 2 - How a cache works.

A cache is a relatively small, super fast memory physically close to the processor chip. Whenever the processor fetches a byte or word for an instruction or for data, the memory request passes first to the cache. The cache checks to see if it already has the data that the processor wants. If it does (a cache 'hit'), it passes it back to the processor, which proceeds at full speed. Because the cache logic is all in hardware, the cache does all the figuring out for a hit virtually instantaneously, and the processor receives data as fast as it would from fast system memory with no wait states and with no special software.

Unfortunately there is another side to this coin. If the requested byte is not in the cache (a cache 'miss') there is an overhead associated with fetching it from the main system memory. This means that it is possible for a caching type board to be actually slower than a regular PC under some circumstances.

Fortunately these circumstances are sufficiently rare in real applications that they are almost never encountered. One case however will be familiar to you. The power on system test of the PC must not be cached, because if it was, some of the timing sensitive tests would fail. This means that on power up, every memory access for the power up self test is a cache miss, and the power up sequence takes a little longer with the Breakthru than without it.

Appendix 3 - Unique features of the Breakthru 286.

There are two kinds of speedup board, memory-on-board and caching. Memory-on-board products tend to be more expensive, more bulky and have compatibility problems. Caching products tend to be a little slower. This is because in their quest for lower cost and simpler design, most caching boards run their clock from the system color burst clock at 7.14 MHz, while the memory-on-board products run at 8MHz.

With Breakthru 286 we decided to build in the extra value of an asynchronous clock running at 8MHz. This called for more sophisticated circuit design to synchronize the system bus cycles and some more parts, but we have proved that the 10% speed bonus was worth it.

Competitive caching boards only have 8K bytes of cache. Breakthru 286 offers double this, 16K. This means that the Breakthru 286 is less likely to suffer a cache miss than the competition. More sophisticated circuit design enabled us to use fewer memory chips for this 16K cache than competitors use for the 8K cache!

Although the Intel 86 series of processors is word (two bytes as a pair) oriented, many instructions execute byte memory fetches. Competitive caching boards must always refresh their cache after a cache miss with an entire word even if they only need one byte. This causes two system memory request cycles when only one is needed. Breakthru 286 only fetches the byte it needs, saving an entire system memory access cycle.

When the 286 processor writes to memory, it completes the write cycle about twice as fast as the memory can take it, since it is running at 8MHz and the memory is only running at 4.77MHz. Competitive boards have the 286 wait until the write is complete

before continuing to the next instruction. The Breakthru 286 buffers its writes, so that the 286 can write to the buffer at high speed, then continue without pause to the next instruction. The buffer logic makes sure that the memory receives the data at the slower rate that it demands, while the processor is getting on with the next operation.

These design refinements justify our claim that the Breakthru 286 is without exception the most technologically advanced speedup board available.

Appendix 4 - Installation on the Compaq.

Installation on the Compaq is considerably more complicated than installation on a regular PC, but if you follow these steps carefully you will have no problems.

Before you start.

We recommend you have the right tools. It is quite possible to remove the screws without a nut driver, but there is a danger of dropping splinters of metal into the computer. So begin by taking off the plastic cover of your computer and checking whether the aluminum inner cover is secured by slot headed hex bolts or torx screws. Torx screws look a bit like phillips screws except that they have a star shaped hole in them rather than a cross. In any event you will need the nut driver. Nut drivers and torx screwdrivers are available for a few dollars at any auto parts store. The sizes you need are Torx T10 (only for more recent models of Compaq), nut driver 1/4" (all models) and nut driver 3/16" (older models only).

You will also need both a medium and a small phillips screwdriver.

1. Switch off and unplug the power cord.

Also unplug all the cables to the expansion boards, such as the printer cable, the serial RS232 cable and so on.

2. Remove the plastic top cover.

This is tough to do unless you know the trick. Even with the trick you need strong hands.

Without the trick: Stick a large flat bladed screwdriver under the cover by the carrying handle and lever it off. This is a frightening process due to the cracking noise, and may take two screw-

drivers, but you are unlikely to cause any damage. But save this technique as a last resort, using the trick is much better.

With the trick: Stand in front of the computer facing the screen. Lean forwards and place your thumbs on the cover about nine inches apart about two inches in from the back of the cover. Your right thumb should be just below and to the left of the nameplate. Make sure your shoulders are directly above your hands so you can apply your entire weight. Curl your fingers over the back of the cover to the seam where the cover and the case meet by the carrying handle. Press downwards on your thumbs very firmly (use your entire weight). The back of the cover will spring outwards. Curl your fingers under the back of the cover and lift it off. Once you get the hang of this you will never mess about with a screwdriver to get it off again.

3. Remove the aluminum inner casing.

- a. Slacken the screws shown in figure 1, but there is no need to remove them entirely, since they engage in slots not holes.
- b. Lift out the aluminum cover.

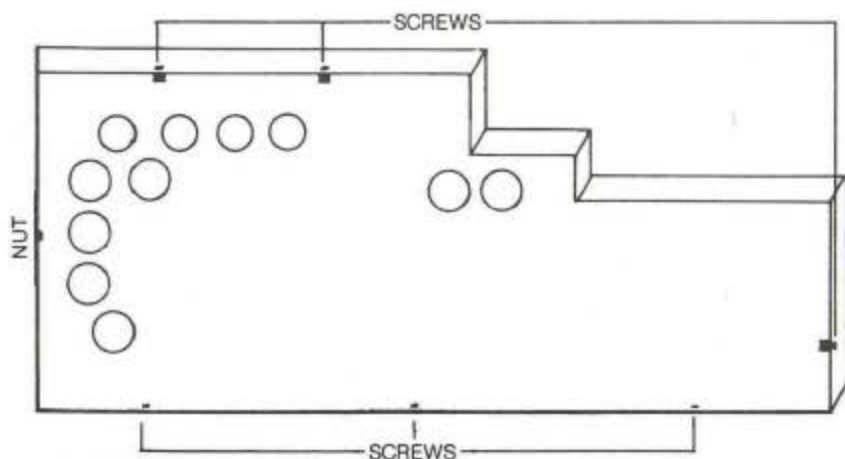

Illustration A4-1

4. Remove the expansion boards.

- a. Take a look at the plug in boards. The two nearest the front of the computer come with it, the shorter one is the disk controller card and the longer one is the video controller card.

Any other cards are add-ons. These could include memory expansion cards, modem cards and hard disk controller cards. If you don't have a slot empty you will have to sacrifice one of these. I got rid of my old modem card because my multifunction card has a serial port on it and external modems are so cheap these days.

- b. Remove the retaining screws from all the expansion boards including the disk controller and video board. The retaining screws for these two are on the outside of the computer.
- c. Disconnect any cables attached to your add-on cards, marking them carefully for location and sense (direction of plugging in). Pull out the add-on cards and put them carefully to one side.
- d. Disconnect the round, grey cable from the video board, noting carefully where it came from. Pull out the video board and lay it to one side.
- e. Disconnect the ribbon cable from the top of the disk controller card. Don't just yank it off, it is retained by the little ears at each end. Lever the ears outwards and the connector will pop off. Pull out the disk controller card and lay it to one side.

5. Remove the 8088 and 8087

- a. This illustration shows the position of the 8088 just behind drive B:

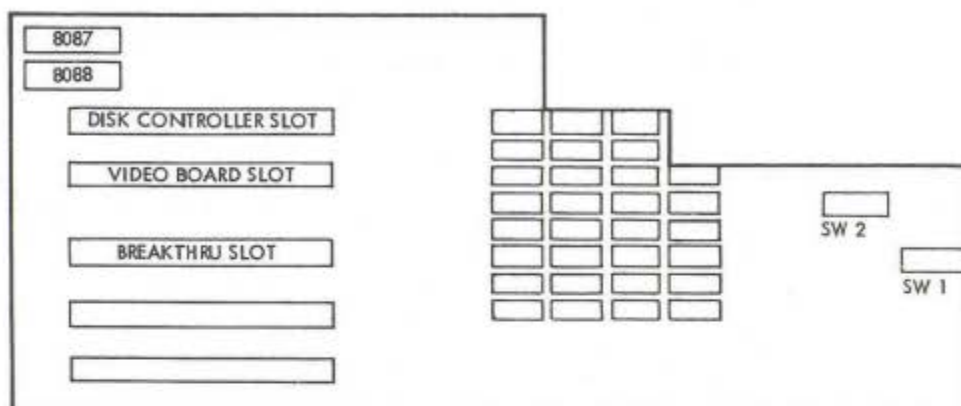

Illustration A4-2

- b. Using the tool provided, lever the 8088 from its socket, making sure that both ends are lifted evenly to avoid bent pins.
 - c. The 8087 socket is next to the 8088 processor, almost under drive B. If you have an 8087, remove it using the tool provided.
- ## 6. Install the 8087 blanking plug
- a. Rest the blanking plug over the 8087 socket. Make sure that pin 1 of the blanking plug is toward the side and the back of the computer. When you are sure that each pin is engaging exactly in the correct socket, carefully rock the plug in all directions to verify that it is exactly in place. Then press it firmly home applying even pressure over the entire top with your fingers. Bear in mind that bent pins is the commonest cause of problems when inserting plugs of this kind.
 - b. If you had an 8087 but you don't have a 287, or if you didn't have an 8087 but you do have

a 287 you will need to reset the math coprocessor switch on the motherboard. This is switch 2 on switch block 1 (SW1). Set this switch ON if you DON'T have a 287. If you DO have a 287, set this switch to OFF.

7. Set up the switches on the Breakthru 286.

See section 3 parts 4 and 5 to set up the memory switches and math coprocessor.

8. Install the Breakthru cable plug

- a. Next we need to plug in the Breakthru 286 cable. Hold the Breakthru card in your left hand and locate the plug end of the cable in the 8088 socket with your right. The cable should be oriented away from the disk drive. When the pins are resting exactly into the correct sockets, press the plug firmly home. Bear in mind that bent pins due to faulty installation is the commonest cause of problems when inserting plugs of this kind.
- b. Rest the Breakthru card on top of the disk drive for a moment.

9. Replace the disk and video cards.

- a. Reinsert the disk controller card, taking care that the inner end engages in the plastic retaining slot. Carefully plug in the disk controller ribbon cable, making sure that it is properly engaged.
- b. Reinsert the video card, again taking care that the inner end engages in the plastic retaining slot. Carefully plug in the round grey video cable to the prongs at the top of the board. Make sure that both rows of prongs are properly engaging in the plug. With this

connector it is possible to have one row of prongs miss the plug altogether, which would cause it not to work.

10. Install the Breakthru card.

- a. Fold the Breakthru cable over the top of the disk controller card and the video card, and plug the Breakthru card into the third slot.

11. Put it all back together

- a. Plug in any other add-on cards that you have.
- b. Replace all the retaining screws for the cards.
- c. Replace the aluminum cover. Make sure that none of the screw heads are caught under the flange, and make sure that the plastic retaining spacers attached to the inside of this cover are engaging properly on the tops of the boards inside. Tighten up the cover retaining screws.
- d. Replace the plastic lid. Do it like this: Holding the lid almost vertically make sure that the three hook-lips are engaging properly at the front end of the computer. Also make sure that the lid is centered laterally. Swing the lid down while holding it firmly into the pivot point. Press it gently into place with a satisfying click.

12. Plug in and power up.

- a. Now plug in and power up. If the cursor doesn't swim into view within a few seconds, turn up the brightness. If still no cursor, take it apart and go through all the steps above again. But more carefully.

Appendix 5 - Installation on other clones

1. Unusual locations for the 8088 and 8087.

The cable on the BREAKTHRU 286 is long enough to reach the processor socket on all the clones we have tested.

Sometimes the 8088 processor is mounted backwards compared to the IBM PC. You can easily accommodate this situation by putting a twist in the cable.

The main point to remember is that the colored stripe on the BREAKTHRU 286 cable should go to the pin 1 end of the 8088 socket. The pin 1 end of the 8088 has a notch in it, and sometimes the number 1 is printed on your motherboard.

2. Turbo Clones.

Some clones offer you the option of running your computer at 8MHz or faster. You must change your FS jumper to work with this higher speed bus - see Appendix 1.

It is VERY IMPORTANT that you don't use any 'Hot Key' combination at your keyboard to try to switch your motherboard to turbo speed and back to regular speed. Your system will certainly crash.

Also, due to the switching method used by some of these clones, it is unfortunately sometimes impossible to set the * jumper vertical to power up in slow mode with software speed switching enabled. If your system hangs with the cursor showing when you switch it on, make sure the * jumper is not in the vertical position.

3. 8086 Clones.

The BREAKTHRU 286 is not compatible with computers using an 8086 processor. The pinout on the 8086 is very different from that of the 8088, and there's no way to adapt it.

Computers that use the 8086 include the IBM PS2 System 30, and the Compaq Deskpro.

Appendix 6 - Compatibility with add-ons.

If you have a board in your system that can only go in slot 8 of an XT, such as the IBM 3270 board, you will need to disable software speed switching by leaving the * jumper off.

If you have an EEMS board that you are using to backfill your system RAM, for example the JRAM III or the AST Premium, you must boot with the caching disabled, or the EEMS board will be confused by the cache. This means that you will be unable to cache your BIOS, which is no great loss unless you run lots of interpreted BASIC programs. Remember to put L CACHE ON in your AUTOEXEC.BAT file to enable caching after startup - see Appendix 1.

Generally speaking it is most unlikely that you will encounter a hardware incompatibility with the BREAKTHRU 286. Software incompatibilities are also rare. If you do find a program that will not run at the BREAKTHRU 286 high speed, try typing L CACHE OFF at the DOS prompt to slow BREAKTHRU 286 down before running that program. You can go back to L CACHE ON after exiting the incompatible program.

Appendix 7 - Software utilities

Software Speed Switching

If you enable software speed switching with the * jumper (see Appendix 1), you will need to install the software that does the switch. The switching is performed by two programs acting in concert, namely BSS.SYS (Breakthru Speed Switch) and L.COM (a special version of Lightning).

BSS.SYS

BSS.SYS must be copied into your boot directory (the same directory as CONFIG.SYS) and specified in your CONFIG.SYS file with the following command:

```
device=BSS.SYS
```

BSS.SYS performs several functions. One of these is to work as a GACD. If you have an EMS application such as Desqview that requires a GACD, you must install BSS.SYS whether you need software speed switching or not.

Lightning

In addition to performing disk speedup, the Lightning provided with Breakthru can switch the speed of operation by enabling or disabling the Breakthru cache. This switch can happen three ways:

1. With a command from the DOS prompt.
2. With a hot key combination.
3. Automatically for diskette operations.

To slow down the BREAKTHRU 286 from the DOS command line type

```
L CACHE OFF
```

To restore the BREAKTHRU 286 to turbo speed from the DOS command line type

L CACHE ON

These commands can either be entered interactively from the keyboard, or they can be in a batch file such as AUTOEXEC.BAT.

To define a hot key combination for switching the cache, you use the the command 'L KEY=' and then a combination of letters saying what the hot key combination should be. Select two or more letters from this list:

- L Left shift key
- R Right shift key
- C Control (Ctrl) key
- A Alt key

So if for example you wanted to switch Breakthru speed by the right shift key and the Ctrl key together, you would type the command

```
L KEY=RC
```

Like all Lightning commands, this is typed at the DOS prompt, and it can be in a batch file or typed directly from the keyboard.

Lightning is smart enough to figure out when you want to access one of your slow floppy disks while running at full speed. With Breakthru running at full speed your floppy disk drive may be too slow and give error messages such as

```
Not ready error reading drive A
```

Lightning can automatically slow down your BREAKTHRU 286 for floppy accesses, for dramatically better floppy compatibility.

If you are unfortunate enough to get an error message like the above, tell Lightning to slow Breakthru down for the problem drive. You do it like this: suppose the problem drive was A. Use the parameter AX when you first invoke Lightning. If drives B and A gave errors, you would use the parameter ABX and so on. The command line for Lightning would look like this:

L 1800 AX

This would reserve 1.8 megabytes of above board memory for Lightning and install speed compensation for drive A. If due to lack of memory you don't want to take advantage of Lightning's disk caching, but you still want to use the speed compensation feature, simply tell Lightning to use zero memory for caching like this:

L 0 AX

If you have switched on speed compensation for drive A, but want to switch it off for some reason, you can tell Lightning like this:

L AY

TEST286 and INVEN

To help verify that your Breakthru is running as it should, we have included two utilities on your Lightning diskette. They are called TEST286.EXE and INVEN.EXE.

TEST286.EXE puts your Breakthru through it's paces. It is run on every board before it is shipped, so it is very unlikely to register an error.

INVEN.EXE explores your system and tries to figure out what's installed. It will give you a list of what it finds. Try it out for fun. If it's wrong we'd appreciate a call so we can update the program. It's main use is to help pinpoint math coprocessor or floppy diskette problems due to motherboard switch settings being faulty.



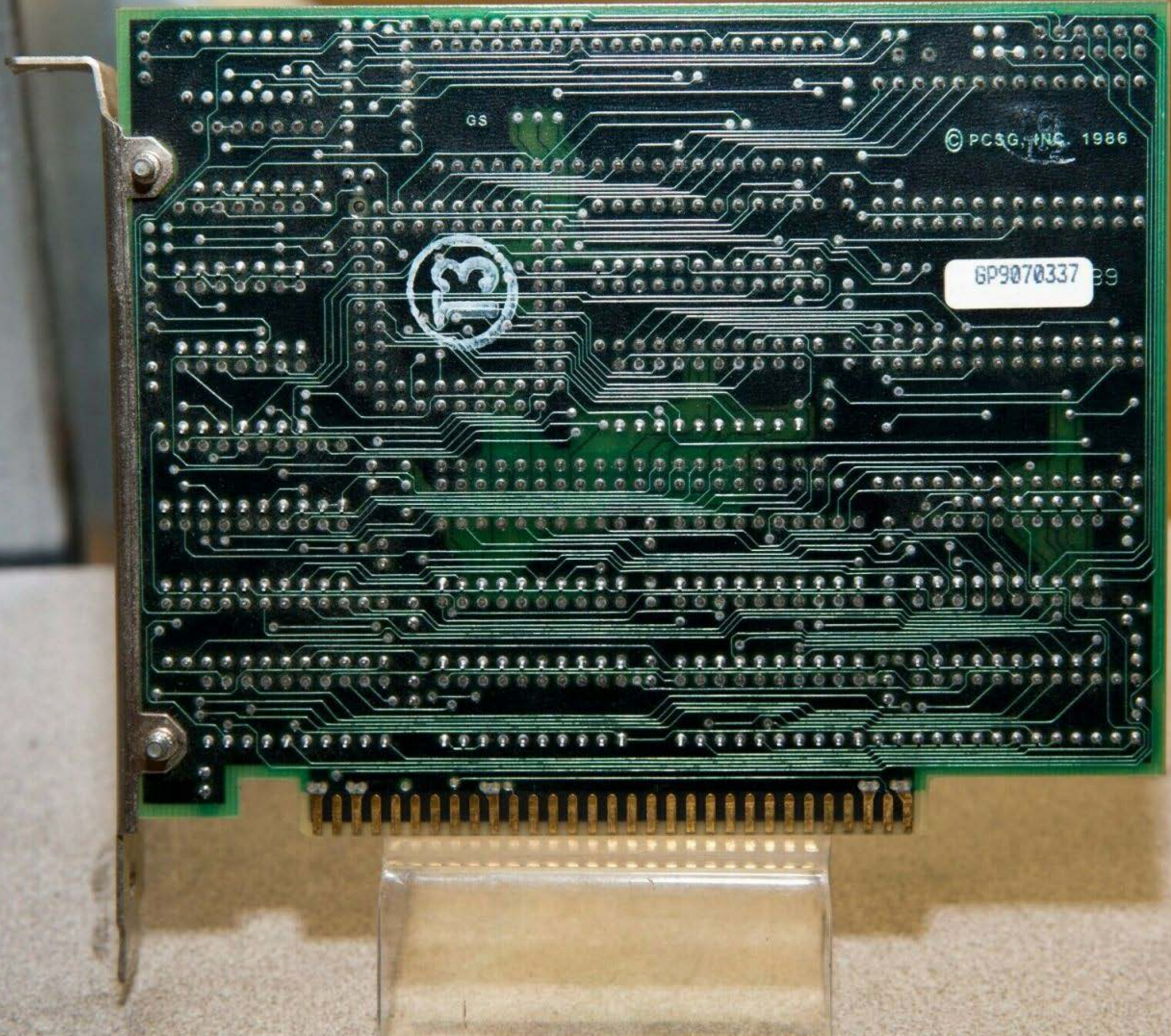

GS

© PCSG, INC. 1986



GP9070337 B9

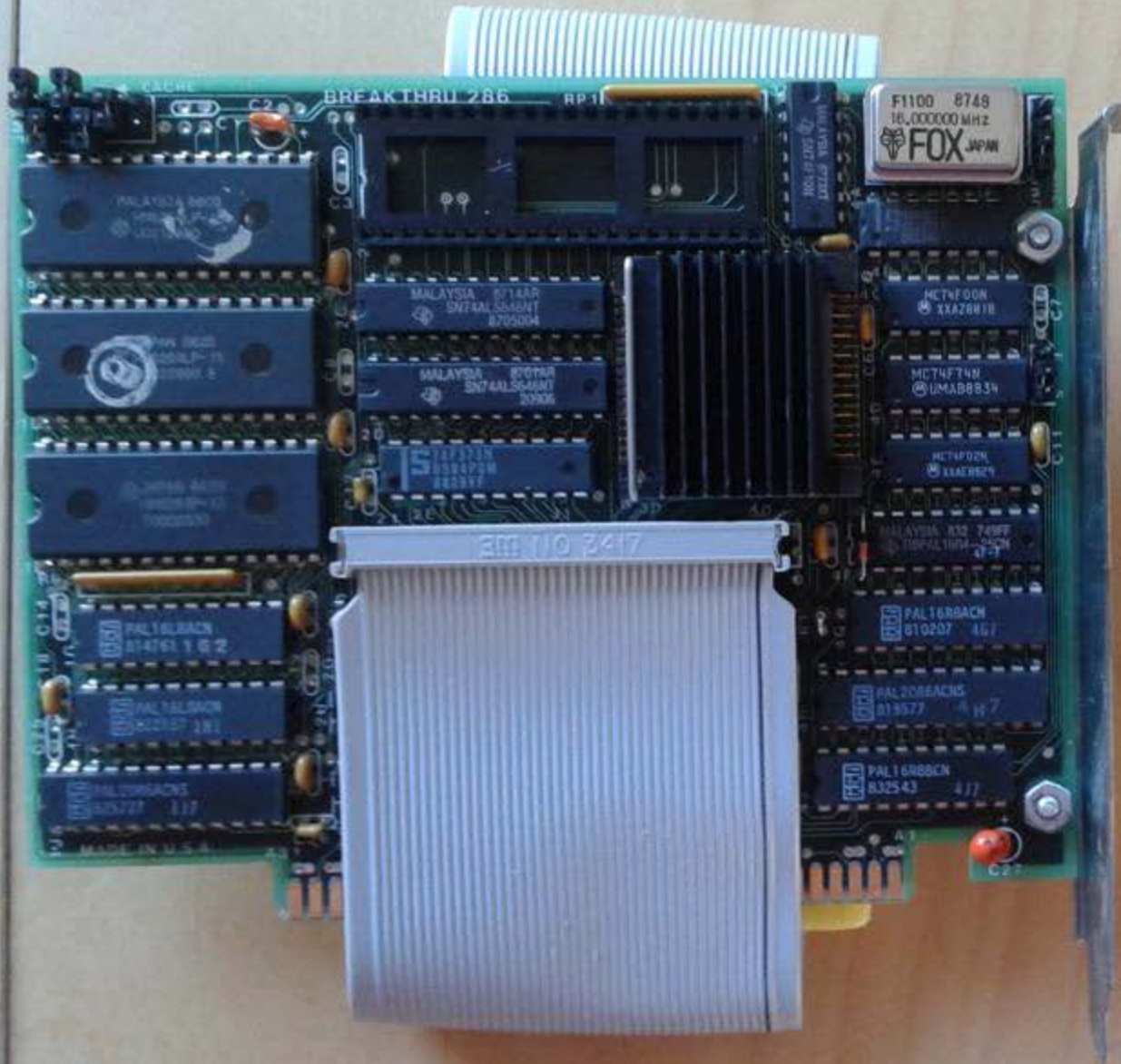

BREAKTHRU 286 BLANKING PLUG
FOR 8087 SOCKET.
MUST BE INSTALLED IN
P.C. MOTHERBOARD

PCSG

PIN 1
↓

MAKE YOUR IBM PC FASTER THAN AN AT.

IN JUST 5 MINUTES!

Introductory
Offer —
~~\$395.00~~



**DON'T TAKE OUR WORD FOR IT.
USE THE BREAKTHRU 286 SPEEDUP
BOARD FOR 60 DAYS. IF YOU ARE NOT
TOTALLY SATISFIED RETURN IT FOR A
FULL REFUND.**

It sounds great; the idea of a speedup board that you can just plug right in as easily as putting bread in a toaster. How wonderful to be able to convert a PC or XT to a \$4000 AT without the expense. But even when you get ready to spend \$595.00 you want to be sure your choice is the very best.

Here at PCSG we sell our IBM PC disk access speedup software by the thousands. But software doesn't do anything about speeding up the microprocessor (or CPU) speed. As you know the microprocessor is the brain of the computer that controls all the operations like screen updates and calculations like a spreadsheet makes.

*Faster and smarter than an AT—
PCSG guarantees it.*

We wanted to offer a speedup card that would be the complement to our disk speedup software, (incidentally included at no extra charge.) We wanted it to be literally the most advanced, compatible and feature rich board available today. We could only be satisfied with a board that was the finest example of the engineering art.

There is no question we have met our every objective by developing and manufacturing the *BREAKTHRU 286* card. This is the best designed and most functional speed up card available today. We guarantee it.

HERE IS WHAT MAKES IT SO SPECIAL.

First, it installs so easily. It is a half slot card, only five inches in length. You don't even have to give up a full slot. What's more, unlike competing products it works in the Compaq and most clones. The instructions are so simple we considered showing a picture of a child putting it in. Easy diagrams show how you just place the card in an open slot, remove the original processor and connect a single cable. There is no software required. From that moment you are running faster than an AT.

Second, it is advanced. The *BREAKTHRU 286* replaces the CPU of the PC or XT with an 80286 microprocessor that is faster

than the one found in the AT. A 16K cache memory provides zero-wait-access to the most recently used code and data. In benchmark tests the card accelerated software programs—both custom and off-the-shelf anywhere from 200% to as much as 700%. Acceleration factor is up to 7.8x on the Norton SysInfofest! Wow!

Third, you have full compatibility. All existing system RAM, hardware, and peripheral cards can be used without software modification. It operates with LAN and mainframe communication products and conforms to the Lotus/Intel/Microsoft Expanded Memory Specification (EMS). Software compatibility is virtually universal.

Fourth, it is the best there is. There are several other boards on the market. Some are priced about the same as the *BREAKTHRU 286* and some are cheaper. We at PCSG have compared them all, but there simply was no comparison. What we discovered is that many cards being sold offer only a marginal speed up in spite of their claims. We found some to be merely versions of the obsolete 8088 or 8086, and others to be just poorly engineered. The 8MHz *BREAKTHRU 286* is unequivocally the best executed and most completely reliable speedup board manufactured today.

PCSG has since early 1983 dominated the lap portable market with ROM software such as a Lucid spreadsheet and Write ROM that reviewers rated as excellent. We were proud to successfully enter the IBM PC market last year with disk access speedup software. Now we are so pleased with the *BREAKTHRU* speedup card. We use them on our own PC's to make them faster than AT's. We are really excited about this product.

PCSG makes the unabashed statement that the *BREAKTHRU 286* card represents more advanced technology than boards by Orchid, Quadram, Victor, Mountain, P.C. Technologies, Phoenix... we could go on.

But an ad can't let you experience it for yourself. That's why we sell the *BREAKTHRU 286* on a 60 day trial. If you aren't completely satisfied return it within 60 days for a full refund. It is priced at \$395. Call today with your MasterCard, Visa, American Express or COD instructions and we will ship your card the very next day.



PERSONAL COMPUTER SUPPORT GROUP

11035 Harry Hines Blvd. #207 • Dallas, Texas 75229

214-351-0564



The Next Generation in

Make Your IBM PC Faster Than an AT in Just 5 Minutes!

<u>ITEM</u>	<u>PRICE</u>	<u>NORTON SI TEST</u>
Breakthru 286 (8MHz)	\$395	7.3 X faster
Breakthru 286-12 (12MHz)	\$595	10.2 X faster
LIGHTNING™ speedup software	FREE with Breakthru \$89.95 purchased separately	

DON'T TAKE OUR WORD FOR IT. USE EITHER BREAKTHRU 286 SPEEDUP BOARD FOR 60 DAYS. IF YOU ARE NOT TOTALLY SATISFIED SIMPLY RETURN FOR A FULL REFUND.

© Copyright 1987 PCSG

We are excited about our three speedup products. You probably know about our Lightning disk access speedup software that was awarded PC magazines's Best of 1986 award (see box). After the smashing success of Lightning, we developed the Breakthru 286 board to be literally the most advanced, fastest, most feature-rich board available. Now we go ourselves one better with the Breakthru 286-12. This new board has the clock speed cranked up from 8 to 12MHz for speeds up to 10.2 times faster than an IBM PC.

From September 1986 we guaranteed that Breakthru was the best designed and most functional speedup card available. And the runaway success it has enjoyed truly proved that assertion.

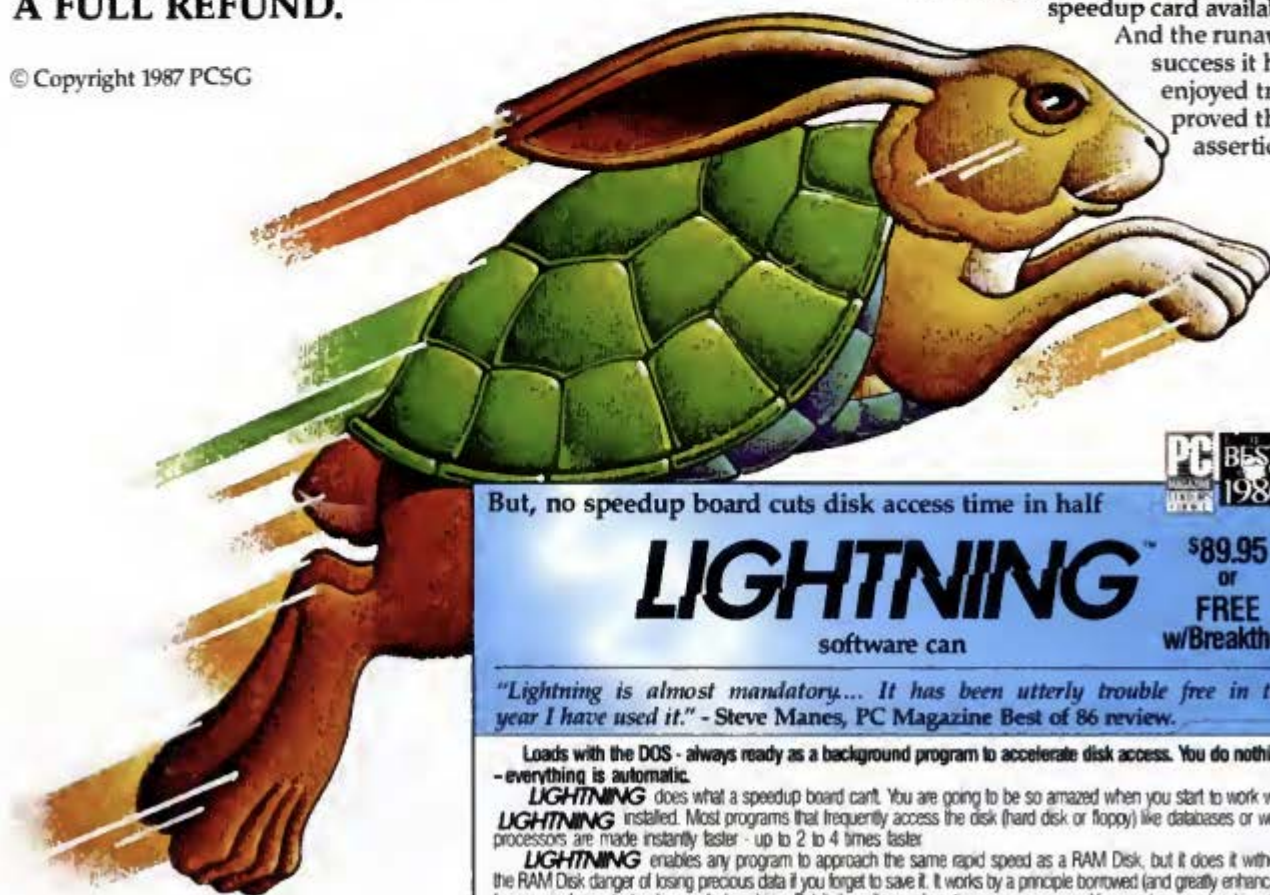

But, no speedup board cuts disk access time in half

LIGHTNING™

software can

PC BEST
AWARD
1986

\$89.95
OR
FREE
w/Breakthru

"Lightning is almost mandatory... It has been utterly trouble free in the year I have used it." - Steve Manes, PC Magazine Best of 86 review.

Loads with the DOS - always ready as a background program to accelerate disk access. You do nothing - everything is automatic.

LIGHTNING does what a speedup board can't. You are going to be so amazed when you start to work with **LIGHTNING** installed. Most programs that frequently access the disk (hard disk or floppy) like databases or word processors are made instantly faster - up to 2 to 4 times faster.

LIGHTNING enables any program to approach the same rapid speed as a RAM Disk, but it does it without the RAM Disk danger of losing precious data if you forget to save it. It works by a principle borrowed (and greatly enhanced) from main frame technology called caching. But it doesn't speed up the microprocessor. You need a speedup board to improve operational speed.

LIGHTNING is the standard against which all our competition measures itself because we achieve universal compatibility with other software and with complete reliability. Data is never lost. **LIGHTNING** fully exploits Above Board memory.

Order **LIGHTNING** separately or get it free with your Breakthru 286 board.

Turn back for
test results

IBM PC Speedup Boards

And now we have a new Breakthru 286-12 board that is 50% faster than the regular Breakthru or regular 8MHz IBM AT, and up to a whopping 1,000% faster than a regular PC.

How wonderful to convert a PC or XT or clone to a \$4000 AT without

the expense. But when you get ready to spend \$395.00 or \$595.00 you want to be sure your choice is the very best.

Faster and smarter than an AT. PCSG guarantees it.

HERE'S WHY THESE TWO BOARDS ARE SO SPECIAL.

First, they install so easily. It is a half-slot card, only five inches in length. You don't even have to give up a full slot. What's more, unlike competing products it works in the Compaq Portable and most clones. Easy diagrams show how you just place the card in an open slot, remove the original processor and connect a single cable. There is no software required. From that moment you are running faster than an AT.

Second, it is advanced. The BREAKTHRU 286 replaces the CPU of the PC or XT with an 80286 microprocessor that is faster than the one found in the AT. You have your choice of 8MHz at \$395 or 12 MHz at \$595. You can plug in an optional 80287 math coprocessor chip

for numeric intensive applications. A 16K cache memory provides zero-wait-access to the most recently used code and data. Look at the benchmark tests box to see how our two boards compare with the PC and the AT. Speed is addictive. You'll never want to go back to slow again.

Third, you have full compatibility. All existing system RAM, hardware, and peripheral cards can be used without software modification. Our boards operate with LAN and mainframe communication products and conform to the Lotus/Intel/Microsoft Expanded Memory Specification (EMS). Software compatibility is virtually universal.

Fourth, these are the best. There are several other boards on the market. We at PCSG have compared them all, but there simply is no comparison. What we discovered is that many cards being sold offer only a marginal speedup in spite of their claims and others are just poorly engineered. For example some boards have a cumbersome mechanical switch for going back to 8088 speed, but the Breakthru boards have speed switching software that allows you to drop back to a lower speed on the fly for timing sensitive applications. The 8MHz BREAKTHRU 286 and the 12MHz are unequivocally the best executed and most completely reliable speedup boards manufactured today.

CIRCLE 489 ON READER SERVICE CARD

We are so pleased with the BREAKTHRU speedup card. We use them on our own PC's to make them faster than AT's. We are really excited about this product.

PCSG makes the unabashed statement that the BREAKTHRU 286 card represents more advanced technology than boards by Orchid, Quadram, P.C. Technologies, Phoenix...we could go on. The Breakthru 286 is undisputedly the fastest turbo board with the biggest bang for the buck. And we include FREE the \$89.95 acclaimed Lightning software, which complements the Breakthru 286 by dramatically speeding up disk operations.

But an ad can't let you experience it for yourself. That's why we sell either BREAKTHRU 286 8MHz or 12MHz on a 60-day trial. If you aren't completely satisfied return it within 60 days for a full refund. Call today with your MasterCard, Visa, American Express or COD instructions and we will ship your card the very next day.



(214) 351-0564

11035 Harry Hines Blvd.
Suite 206
Dallas, Texas 75229

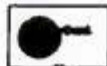

"The Breakthru 286 performed flawlessly with every application we handed it, including copy-protected programs and nine memory-resident utilities at one."
Stephen Manes, PC Magazine

"...the Breakthru 286 was the card of choice."
PC BusinessSoftwareview (Rated #1)

"...Breakthru 286 is a good value and a quality product backed by effective support."

Dan A. Griffin
The Newsletter of the AutoCAD User's Group

"The PCSG Breakthru 286 achieved the best performance results of the caching boards tested."
Ted Mirecki, PC Tech Journal (Rated #1)

"The 12-MHz Breakthru 286-12 speedup board is the fastest of those tested, but not the most expensive. On a dollar per-horsepower basis, it could be called the cheapest boost available for an XT."

Mark Welch, InfoWorld (Rated #1)

Think You Need an AT?

Make Your IBM PC Faster Than an AT in Just 5 Minutes!

Accelerator Cards: Speed and Value

Speed figures are consolidated results from 10 tests of CPU performance (See Accelerator Boards Special Report, December 1, 1986.)

<input type="checkbox"/> Microspeed Fast 88	\$149
<input type="checkbox"/> Microsoft Mach 10	\$395
<input type="checkbox"/> Univation Dream Board	\$512
<input type="checkbox"/> Orchid Turbo EGA	\$945
<input type="checkbox"/> ST&D Standard 286	\$995
<input type="checkbox"/> Classic Speedpack	\$995
<input type="checkbox"/> Orchid PC-Turbo 286e	\$1,195
<input type="checkbox"/> Breakthru 286-12	\$595

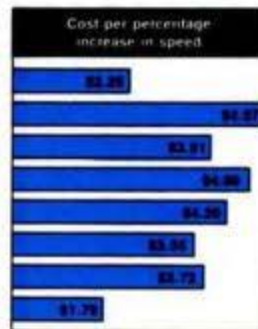
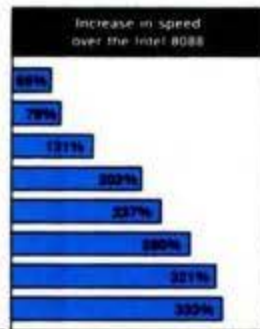

REPRINTED FROM INFOWORLD, APRIL 27, 1987

Breakthru 286-8MHz-\$395
Breakthru 286-12MHz-\$595

LIGHTNING™—FREE with Breakthru
speedup hardware—\$89.95 purchased separately

We are excited about our three speedup products. You probably know about our Lightning disk access speedup software that was awarded PC Magazine's Best of 1986 award (see box). After the smashing success of Lightning, in late '86, we

guaranteed the Breakthru 286 board to be literally the most advanced, fastest, most feature-rich board available. The runaway success it has enjoyed truly proved that assertion. Now we go ourselves one better with the Breakthru 286-12. This new board has the clock speed cranked up from 8 to 12 MHz for speeds up to 10.2 times faster than an IBM PC. It is 50% faster than an 8MHz IBM AT, and up to a whopping 1,000% faster than a regular PC.

HERE'S WHY THESE TWO BOARDS ARE SO SPECIAL.

First, they install so easily. A half-slot card means you don't even have to give up a full slot. What's more, unlike competing

products it works in the Compaq Portable and most clones. Easy diagrams show how you just place the card in an open slot, remove the original processor and connect a single cable. There is no software required. From that moment you are running faster than an AT.

Second, they are advanced. The BREAKTHRU 286 replaces the CPU of the PC or XT with an 80286 microprocessor that is faster than the one found in the AT. Has a 80287 math coprocessor slot for numeric intensive applications. A 16K cache memory provides zero-wait-access to the most recently used code and data. Speed switching software allows you to drop back to a lower speed on the fly for timing sensitive applications.

Third, you have full compatibility. All existing system RAM, hardware, and peripheral cards can be used without software modification. Our boards operate with LAN and mainframe communication products and conform to the Expanded Memory Specification (EMS). Software compatibility is virtually universal.

Faster and smarter than an AT - PCSG guarantees it.

Fourth, these are the best. There are several other boards on the speedup market. We at PCSG have compared them all, but there simply is no comparison. Many cards offer only a marginal speedup in spite of their claims and others are just poorly engineered.

We are really excited about these products. PCSG makes the unabashed statement that the BREAKTHRU 286 card represents more advanced technology than boards by Orchid, Quadram, P.C.

Technologies, Phoenix...we could go on. Breakthru 286 is undisputedly the turbo board with the biggest bang for the buck. And we include FREE the \$89.95 acclaimed Lightning software. Call today with your credit card or COD instructions and we will ship your card the very next day.

But, no speedup board cuts disk access time in half

LIGHTNING™

software can - \$89.95 or FREE w/Breakthru

"Lightning is almost mandatory..." -
Steve Manes, PC Magazine
Best of 86 review

Loads with the DOS - always ready as a background program to accelerate disk access. You do nothing - everything is automatic. Programs that frequently access the disk (hard or floppy) are made instantly up to 2 to 4 times faster. Uses a principle greatly enhanced from mainframe technology called caching. Fully exploits Above Board memory.

LIGHTNING is the standard against which all our competition measures itself because we achieve universal compatibility with other software. Data is never lost. Order **LIGHTNING** separately or get it free with your Breakthru 286 board.

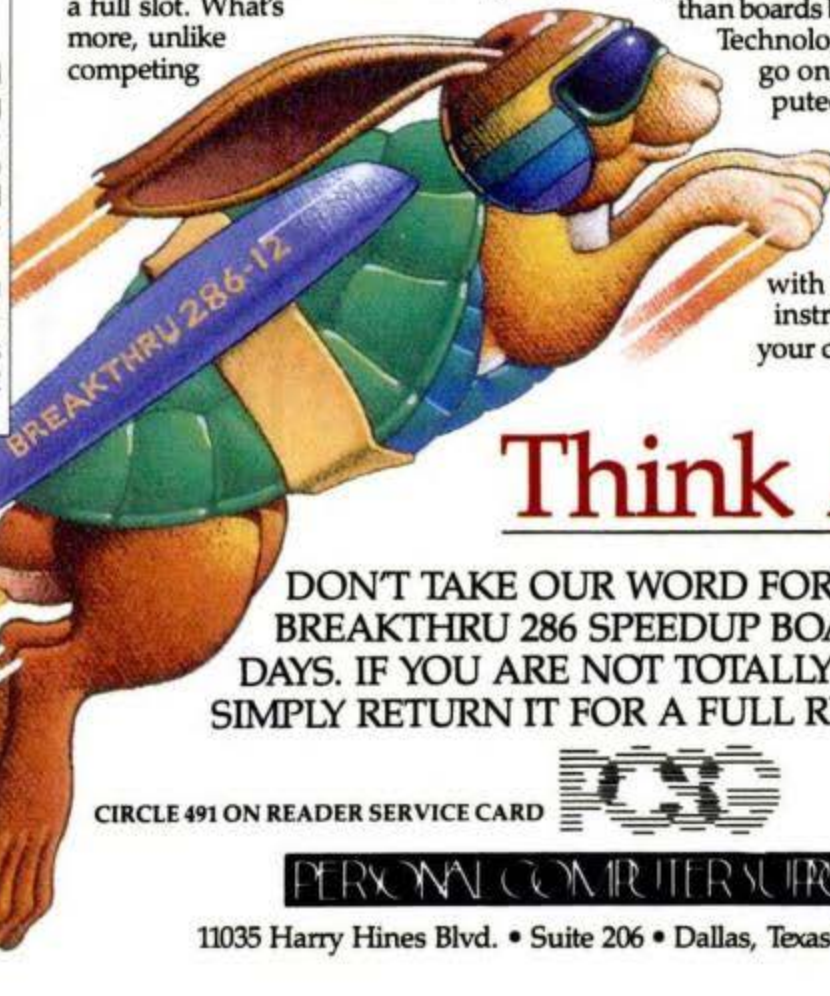

Think Again.

DON'T TAKE OUR WORD FOR IT. USE EITHER BREAKTHRU 286 SPEEDUP BOARD FOR 60 DAYS. IF YOU ARE NOT TOTALLY SATISFIED SIMPLY RETURN IT FOR A FULL REFUND.

CIRCLE 491 ON READER SERVICE CARD



PERSONAL COMPUTER SUPPORT GROUP

11035 Harry Hines Blvd. • Suite 206 • Dallas, Texas 75229 • (214) 351-0564



Personal Computer Support Group
4540 Beltway Drive
Dallas, TX 75244
1-214-404-4000