

1918

Service Manual

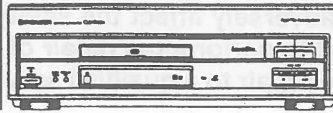

ORDER NO.
RRV1693

CD CDV LD PLAYER

CLD-D406

THIS MANUAL IS APPLICABLE TO THE FOLLOWING MODEL(S) AND TYPE(S).

Type	Model	Power Requirement	Remarks
	CLD-D406		
KU	○	AC120V	
KC	○	AC120V	

CONTENTS

1. SAFETY INFORMATION.....	2	7.2 DIAGNOSIS.....	58
2. EXPLODED VIEWS AND PARTS LIST.....	3	7.2.1 SELF-DIAGNOSTIC FUNCTIONS.....	58
3. SCHEMATIC DIAGRAMS.....	14	7.2.2 AGEING MODE.....	60
4. PCB CONNECTION DIAGRAMS.....	26	7.2.3 DISASSEMBLY/ASSEMBLY.....	61
5. PCB PARTS LIST.....	33	7.3 EXPLANATION.....	64
6. ADJUSTMENTS.....	36	7.3.1 BLOCK DIAGRAM.....	64
7. GENERAL INFORMATION.....	48	7.3.2 DIAGNOSTIC LAND MARK AND PATTERN.....	70
7.1 PARTS.....	48	8. PANEL FACILITIES AND SPECIFICATIONS.....	71
7.1.1 IC.....	48		
7.1.2 DISPLAY.....	57		

1. SAFETY INFORMATION

This service manual is intended for qualified service technicians; it is not meant for the casual do-it-yourselfer. Qualified technicians have the necessary test equipment and tools, and have been trained to properly and safely repair complex products such as those covered by this manual. Improperly performed repairs can adversely affect the safety and reliability of the product and may void the warranty. If you are not qualified to perform the repair of this product properly and safely, you should not risk trying to do so and refer the repair to a qualified service technician.

WARNING

Lead in solder used in this product is listed by the California Health and Welfare agency as a known reproductive toxicant which may cause birth defects or other reproductive harm (California Health & Safety Code, Section 25249.5).

When servicing or handling circuit boards and other components which contain lead in solder, avoid unprotected skin contact with the solder. Also, when soldering do not inhale any smoke or fumes produced.



NOTICE

(FOR CANADIAN MODEL ONLY)

Fuse symbols  (fast operating fuse) and/or  (slow operating fuse) on PCB indicate that replacement parts must be of identical designation.

REMARQUE

(POUR MODÈLE CANADIEN SEULEMENT)

Les symboles de fusible  (fusible de type rapide) et/ou  (fusible de type lent) sur CCI indiquent que les pièces de remplacement doivent avoir la même désignation.

(FOR USA MODEL ONLY)

1. SAFETY PRECAUTIONS

The following check should be performed for the continued protection of the customer and service technician.

LEAKAGE CURRENT CHECK

Measure leakage current to a known earth ground (water pipe, conduit, etc.) by connecting a leakage current tester such as Simpson Model 229-2 or equivalent between the earth ground and all exposed metal parts of the appliance (input/output terminals, screwheads, metal overlays, control shaft, etc.). Plug the AC line cord of the appliance directly into a 120V AC 60Hz outlet and turn the AC power switch on. Any current measured must not exceed 0.5mA.

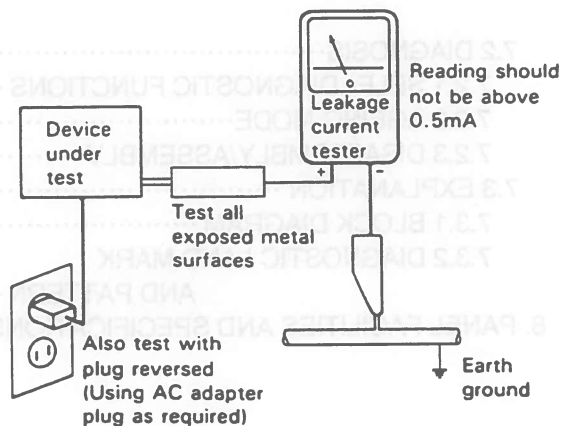

AC Leakage Test

ANY MEASUREMENTS NOT WITHIN THE LIMITS OUTLINED ABOVE ARE INDICATIVE OF A POTENTIAL SHOCK HAZARD AND MUST BE CORRECTED BEFORE RETURNING THE APPLIANCE TO THE CUSTOMER.

2. PRODUCT SAFETY NOTICE

Many electrical and mechanical parts in the appliance have special safety related characteristics. These are often not evident from visual inspection nor the protection afforded by them necessarily can be obtained by using replacement components rated for voltage, wattage, etc. Replacement parts which have these special safety characteristics are identified in this Service Manual.

Electrical components having such features are identified by marking with a Δ on the schematics and on the parts list in this Service Manual.

The use of a substitute replacement component which does not have the same safety characteristics as the PIONEER recommended replacement one, shown in the parts list in this Service Manual, may create shock, fire, or other hazards.

Product Safety is continuously under review and new instructions are issued from time to time. For the latest information, always consult the current PIONEER Service Manual. A subscription to, or additional copies of, PIONEER Service Manual may be obtained at a nominal charge from PIONEER.

2. EXPLODED VIEWS AND PARTS LIST

- NOTES:
- Parts marked by "NSP" are generally unavailable because they are not in our Master Spare Parts List.
 - The Δ mark found on some component parts indicates the importance of the safety factor of the part. Therefore, when replacing, be sure to use parts of identical designation.
 - Screws adjacent to \blacktriangledown mark on the product are used for disassembly.

2.1 PACKING

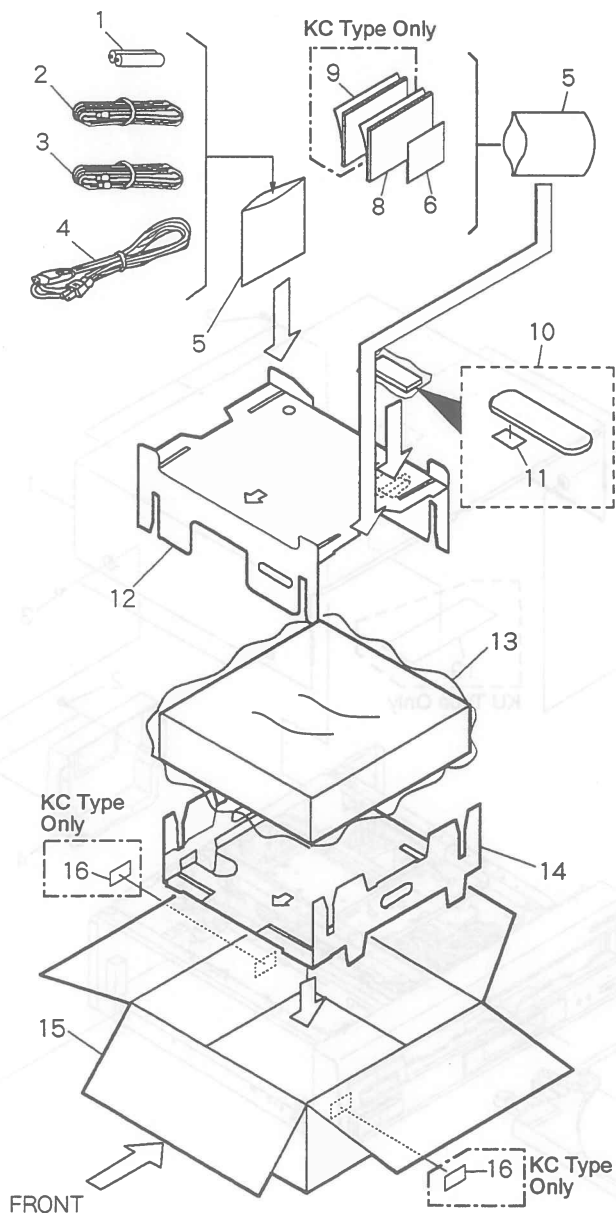

(1) PARTS LIST

Mark	No.	Description	Part No.
NSP	1	Dry Cell Battery (R6P, AA)	VEM-013
	2	Video Cord	VDE1036
	3	Audio Cord	VDE1033
Δ	4	AC Power Cord	ADG1152
	5	Polyethylene Bag 0.03 x 230 x 340	Z21-038
NSP	6	Warranty Card	See Contrast table (2)
	7	•••••	
	8	Operating Instructions (English)	VRB1179
	9	Operating Instructions (French)	See Contrast table (2)
	10	Remote Control Unit (CU-CLD134)	VXX2400
	11	Battery Cover	VNK2806
	12	Protector (Upper)	VHB1042
	13	Mirror Mat	DHL1006
	14	Protector (Under)	VHB1041
	15	Packing Case	VHG1651
	16	KC Label	See Contrast table (2)

(2) CONTRAST TABLE

CLD - D406/KU and KC have the same construction except for the following:

Mark	No.	Symbol & Description	Part No.		Remarks
			CLD - D406/KU	CLD - D406/KC	
NSP	6	Warranty Card	ARY1044	ARY1039	
	9	Operating Instructions (French)	Not used	VRC1052	
	16	KC Label	Not used	VRW1402	

2. EXPLODED VIEWS AND PARTS LIST

2.2 EXTERIOR AND DISC TRAY SECTION

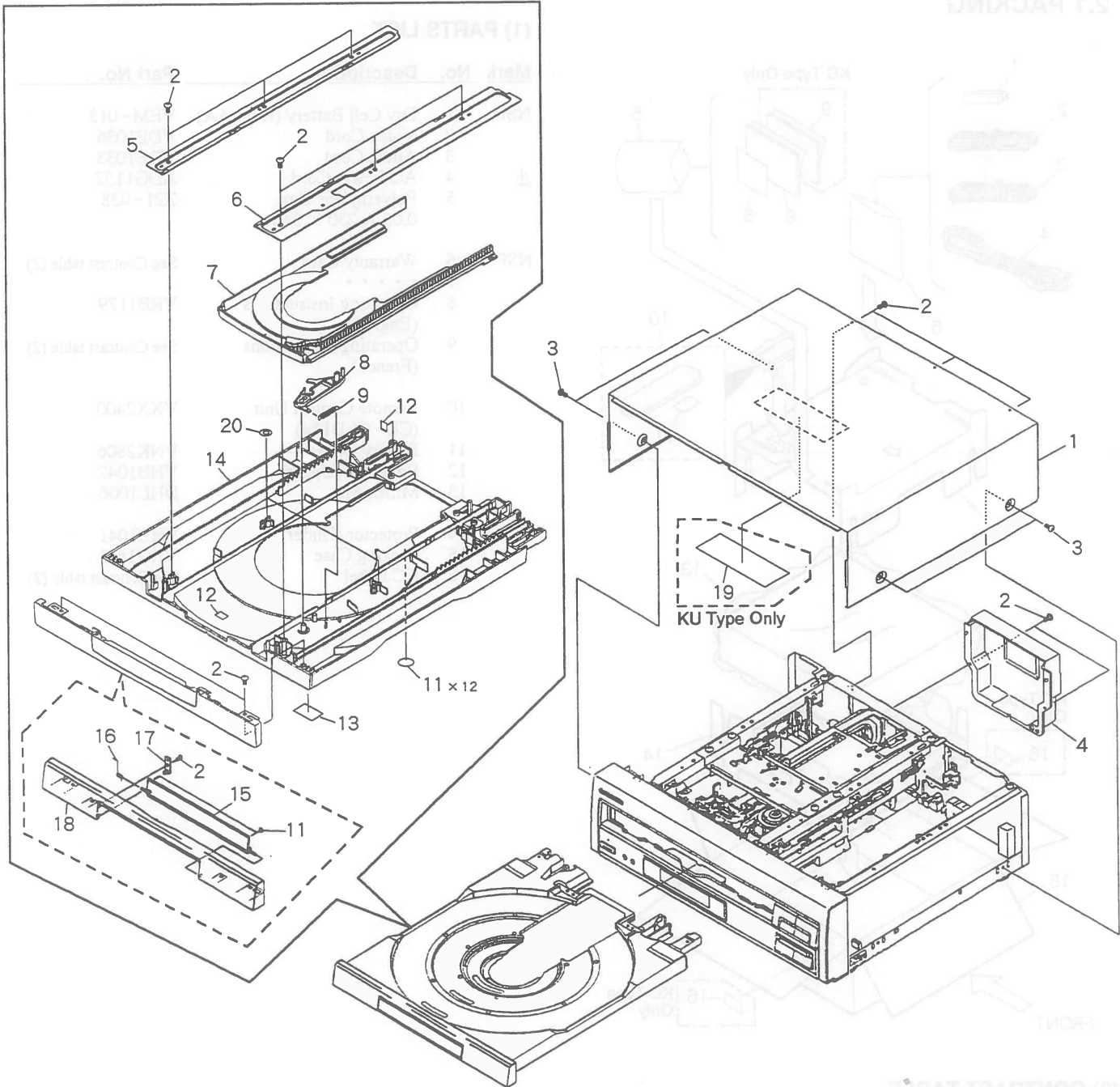

Mark No.	Symbol & Description	Part No.	Remarks
10	KC Label	VRW1402	Not used
9	Operating Instructions (French)	VRG1022	Not used
8	Warranty Card	ARY1044	Not used

(1) PARTS LIST

Mark	No.	Description	Part No.	Mark	No.	Description	Part No.
	1	Bonnet S	VXX2252		11	Cushion	VEC1682
	2	Screw	BBZ30P080FMC		12	Damp Cushion	VEC1683
	3	Screw	BCZ40P060FZK	NSP	13	Label	VRW1289
	4	Rear Cover	VNK3950		14	LD Tray Assy	VXA2173
	5	Guide Plate (R)	VNE1939		15	CD Door Assy	VXA2321
	6	Guide Plate (L)	VNE1938		16	Door Spring	VBH1248
	7	CD Tray	VNK3007		17	Door Holder	VNL1704
	8	Look Plate	VNL1703		18	Tray Panel	VNK3929
	9	Look Plate Spring	VBH1188		19	65 Label	See Contrast table (2)
	10			20	Washer	VEC1254

(2) CONTRAST TABLE

CLD - D406/KU and KC have the same construction except for the following:

Mark	No.	Symbol & Description	Part No.		Remarks
			CLD - D406/KU	CLD - D406/KC	
	19	65 Label	ORW1069	Not used	

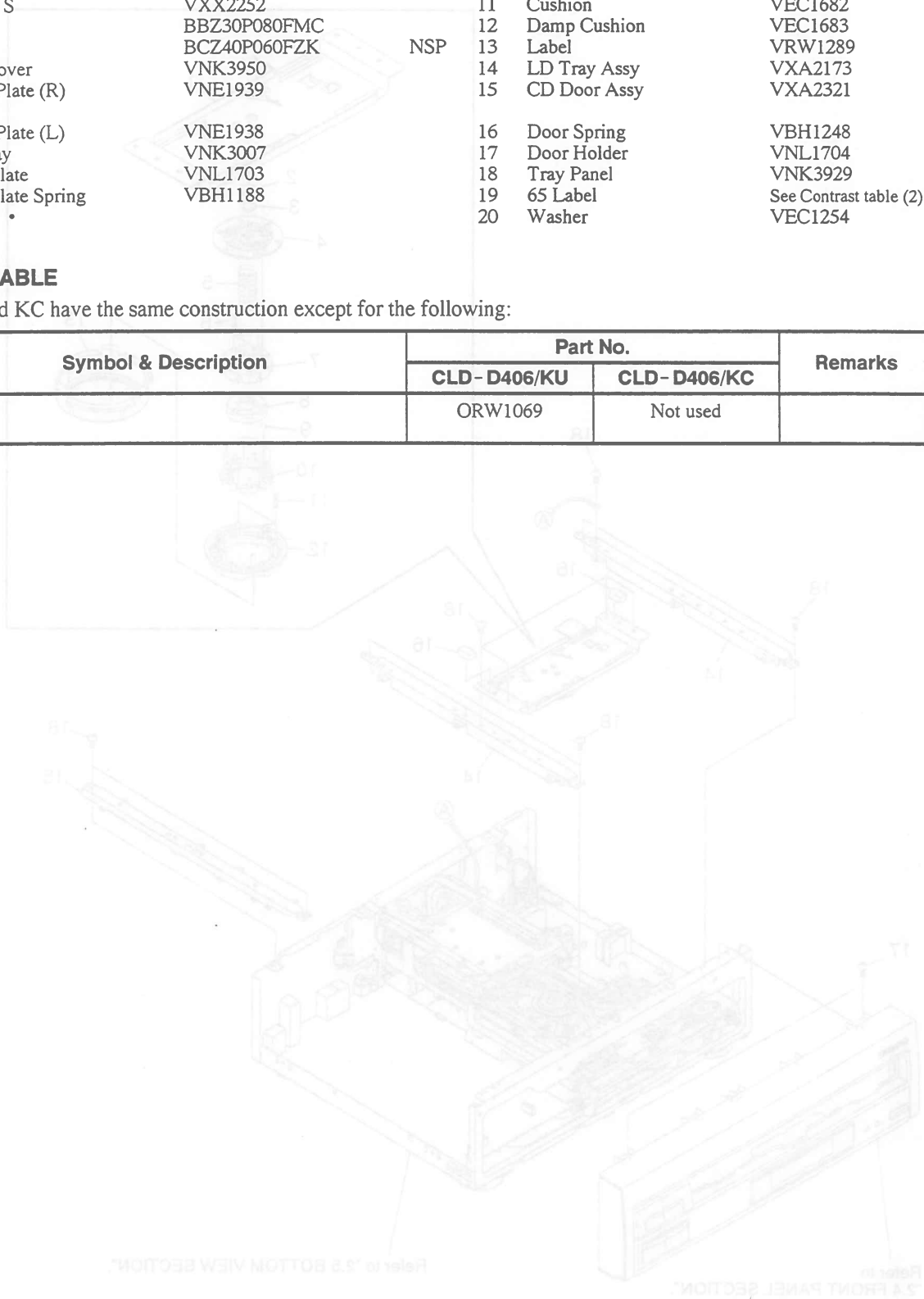

2.3 TOP VIEW SECTION

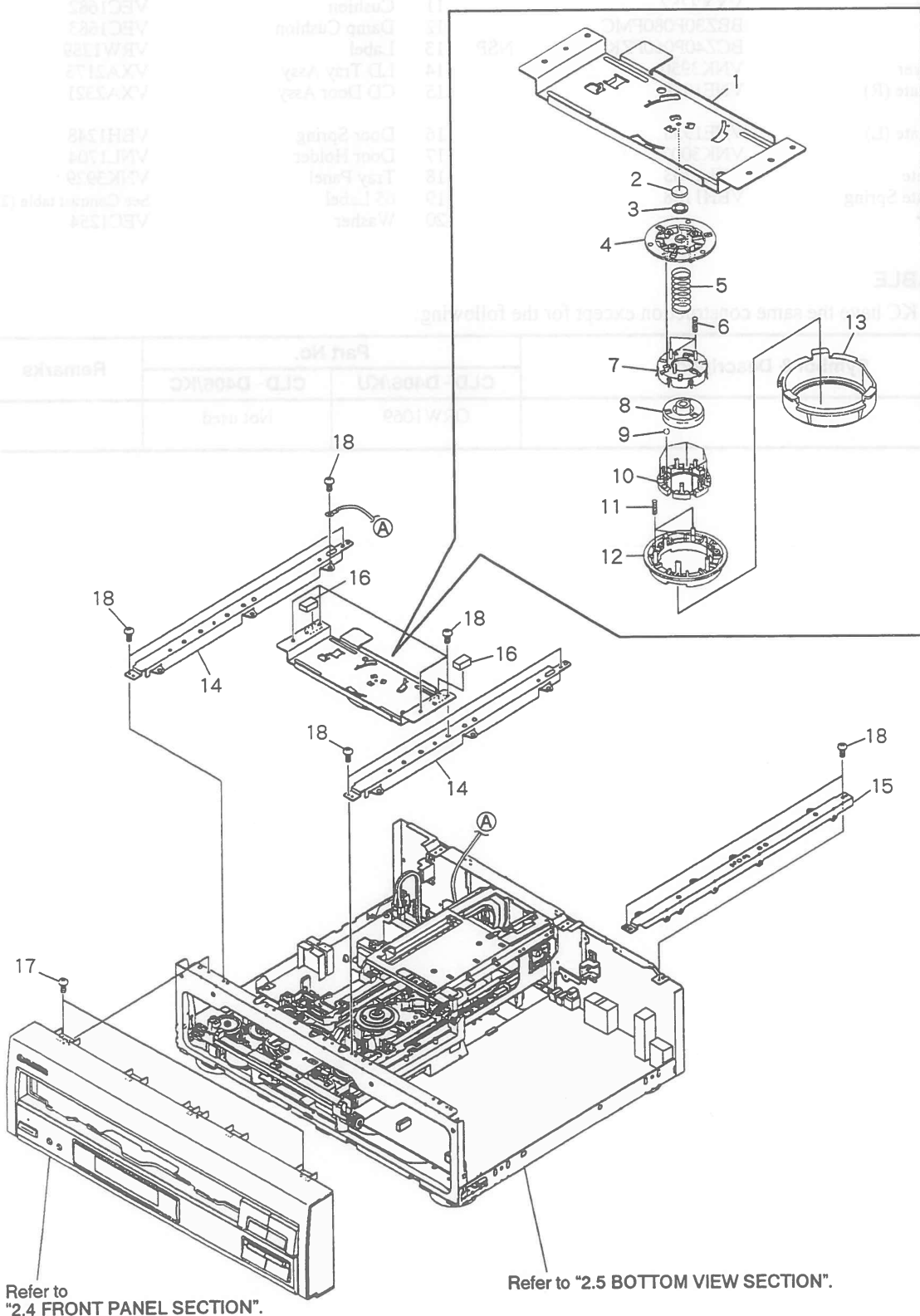

Parts List

Mark No.	Description	Part No.	Mark No.	Description	Part No.
1	Center Plate	VNE1971	11	Clamp Spring	VBH1239
2	Rubber Mat	VEB1114	12	Clamper	VNL1604
3	Thrust Holder	VNL1663	13	Clamper Holder	VNL1680
4	Clamper Head	VNL1603	14	Center Angle	VNE1965
5	LD Spring	VBH1240	NSP 15	PCB Holder	VNE1964
6	Cover Spring	VBH1234	NSP 16	Damp Cushion	VEC1602
7	Ball Cover	VNL1602	17	Screw	IBZ30P080FMC
8	LD Hab	VNT1047	18	Screw	BBZ30P080FMC
9	Ball	VNX1013			
10	Ball Guide	VNL1616			

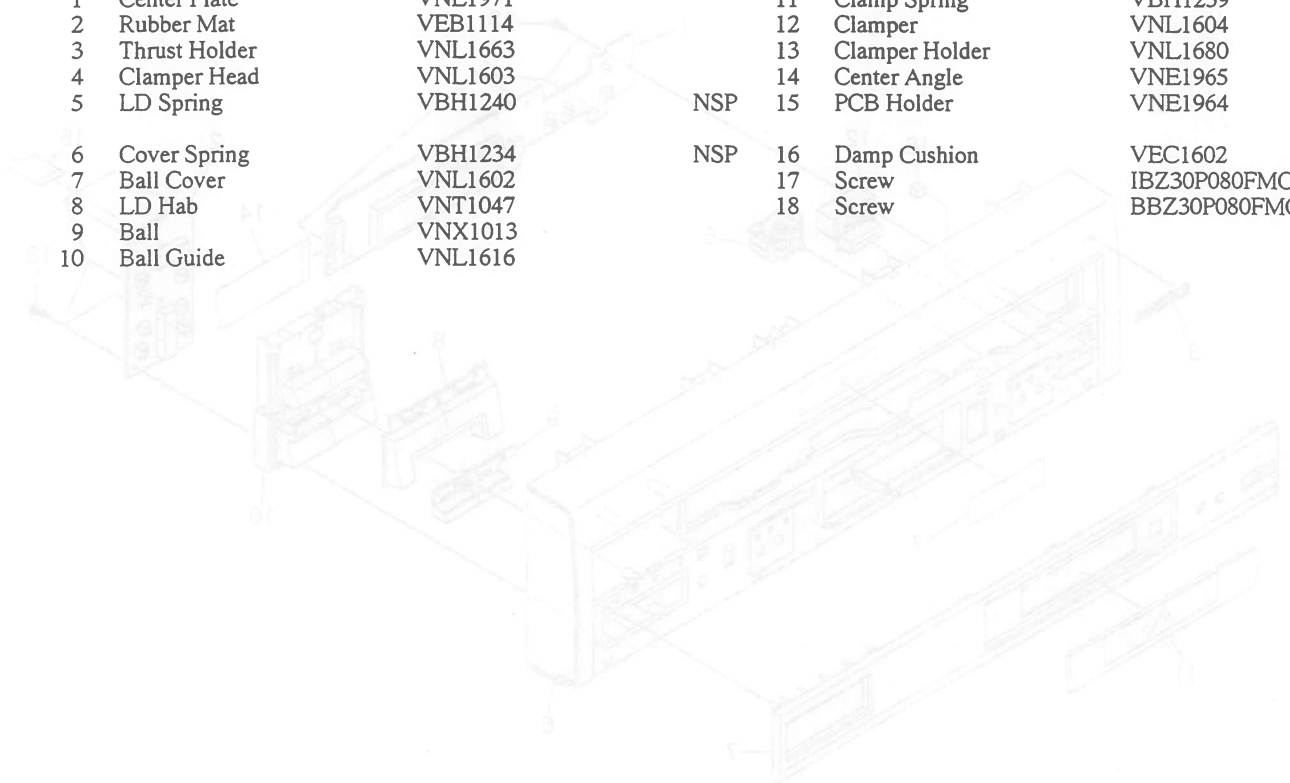

Parts List

Mark No.	Description	Part No.	Mark No.	Description	Part No.
1	FLKY Assy	VWG1810	11	FL Lens	VEC1402
2	KEYB Assy	VWG1811	12	PW Emission	VNK339
3	Main Panel	PAM1808	13	Socket	BBZ30P080FMC
4		14	Flexible Cable (21P)	VDA1587
5	J. Key-C	VNK3070		FLKY CN101-KEYB CN201	
6	Front Panel	VNK3926	15	Flexible Cable (16P)	VDA1588
7	Sub Panel	VNK3931		KEYB CN103-MOTHER CN121	
8	Open Key	VNK3933	16	LED Lens	BWV2019
9	Strip Key	VNK3935	NSP 17	Getter Label	VRW1530
10	Main Key	VNK3937			

2.4 FRONT PANEL SECTION

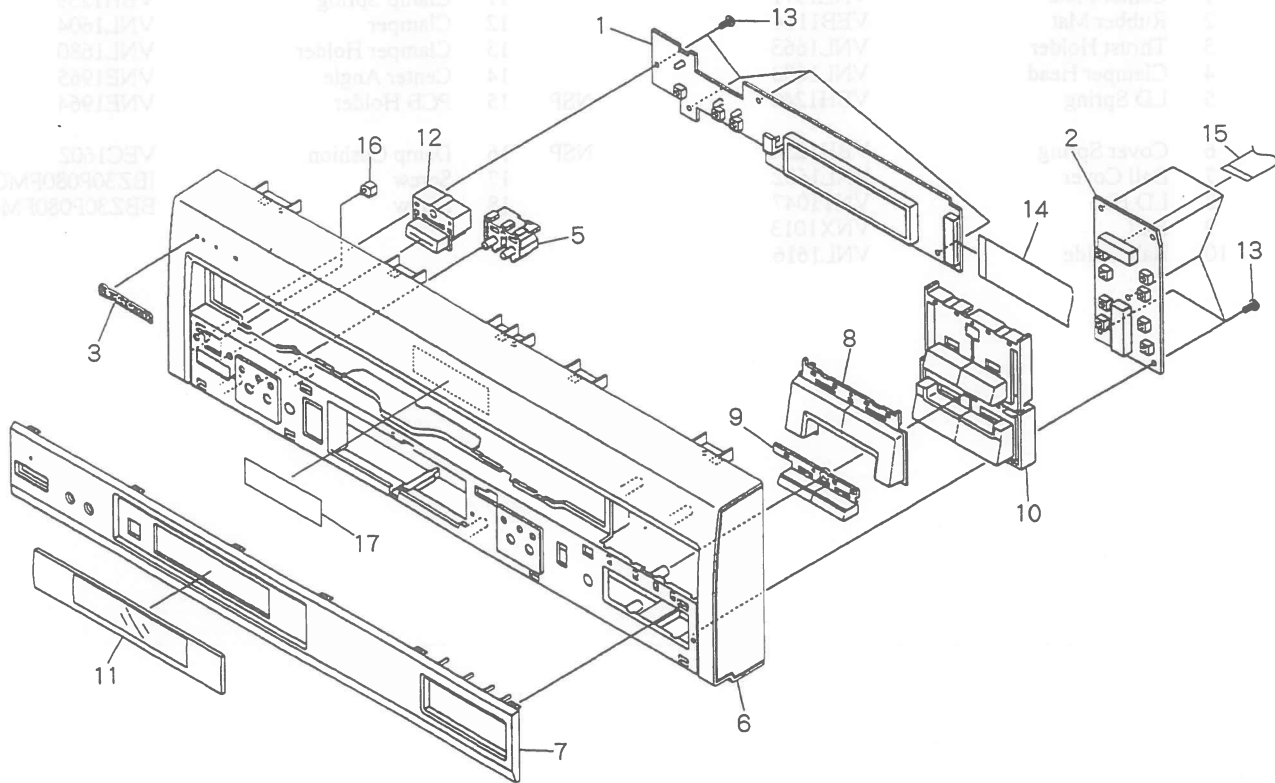

Parts List

Mark No.	Description	Part No.	Mark No.	Description	Part No.
1	FLKY Assy	VWG1810	11	FL Lens	VEC1903
2	KEYB Assy	VWG1811	12	PW Button	VNK2329
3	Name Plate	PAM1608	13	Screw	BBZ30P080FMC
4	•••••		14	Flexible Cable (21P) (FLKY CN101 - KEYB CN201)	VDA1567
5	L Key C	VNK3070	15	Flexible Cable (16P) (KEYB CN203 - MOTHER CN121)	VDA1566
6	Front Panel	VNK3926	16	LED Lens	PNW2019
7	Sub Panel	VNK3931	NSP 17	Getter Label	VRW1636
8	Open Key	VNK3933			
9	Skip Key	VNK3935			
10	Main Key	VNK3937			

2.5 BOTTOM VIEW SECTION

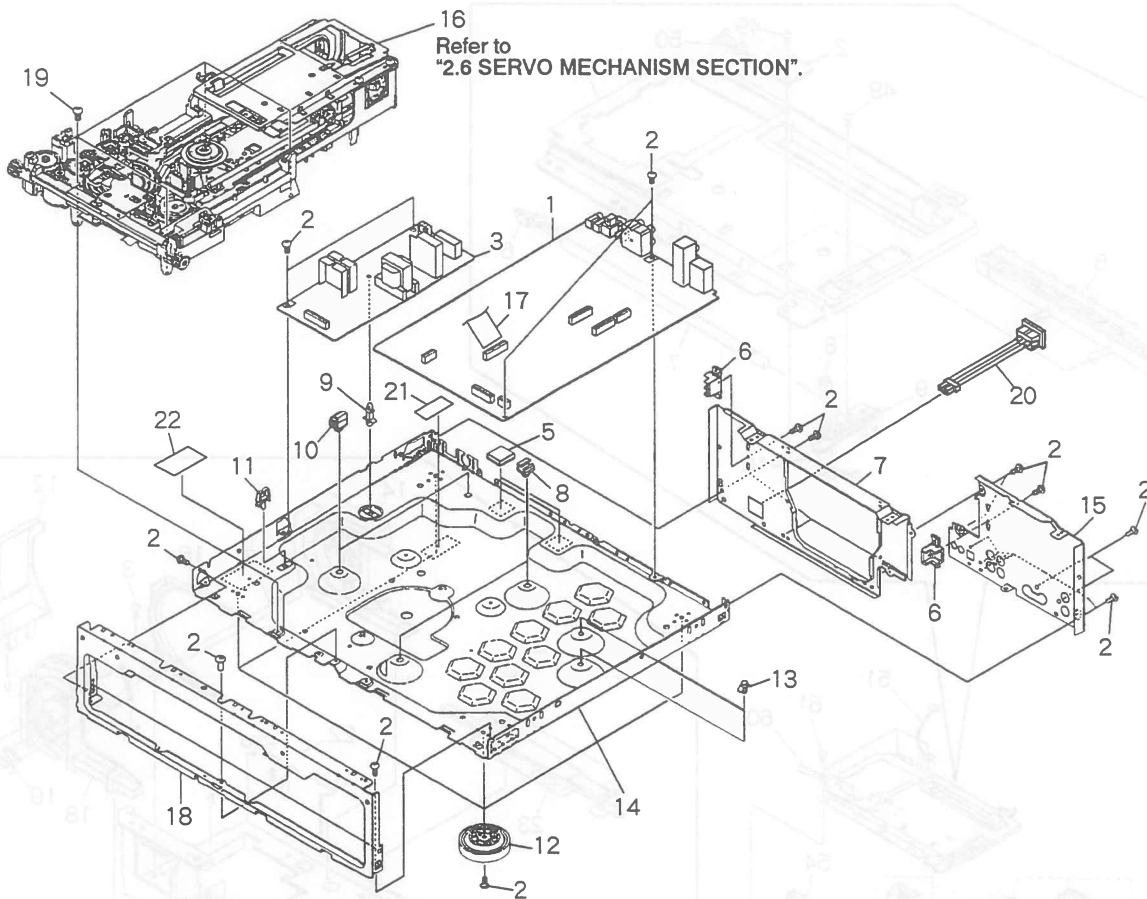

Parts List

Mark	No.	Description	Part No.	Mark	No.	Description	Part No.
	1	MOTHER Assy	VWS1281		11	Wire Clip (H)	VEC1181
	2	Screw	BBZ30P080FMC		12	Insulator	PNW1912
△	3	POWER SUPPLY Assy	VWR1232		13	Card Spacer A	VEC1708
	4	•••••		NSP	14	Chassis	VNA1461
NSP	5	Rubber Spacer	VEB1252		15	Rear Panel L	VNA1819
	6	Tray Stopper	VNL1657	NSP	16	Mechanism Assy	VWT1131
	7	Rear Panel R	VNA1606		17	Flexible Cable (21P) (MOTHER CN102- POWER SUPPLY CN3)	VDA1465
NSP	8	P. Plate Holder	PNY-405	NSP	18	Panel Holder	VNA1835
NSP	9	PC Support	VEC-269		19	Screw	BBZ30P100FMC
	10	PCB Hinge	VEC1174		20	AC Inlet Assy	VKP2126
				NSP	21	Fuse Caution Label (G)	VRW-548
					22	Caution Label	VRW1486

2.6 SERVO MECHANISM SECTION

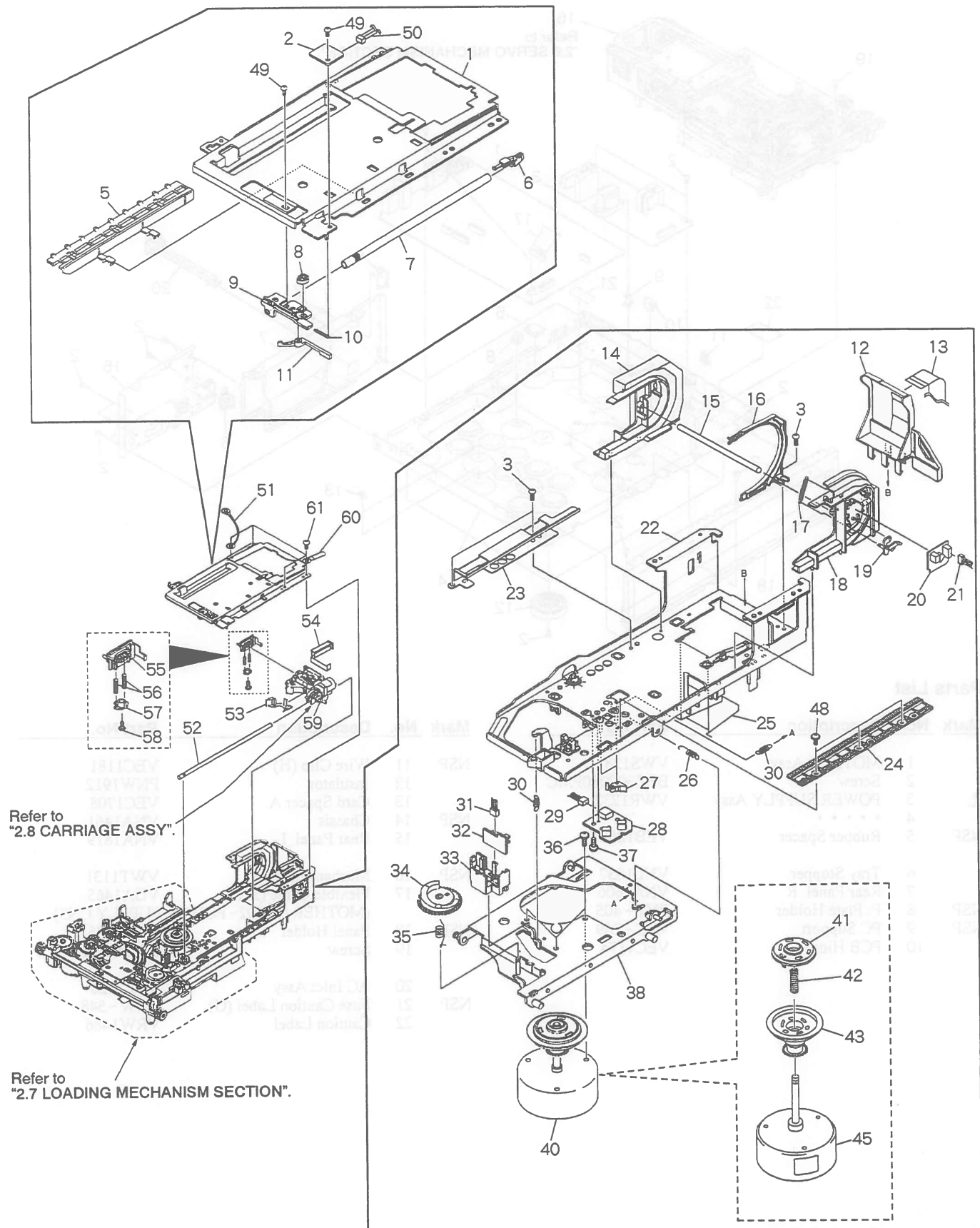

Parts List

Mark	No.	Description	Part No.	Mark	No.	Description	Part No.
NSP	1	Tilt Base (upper)	VNE1969	NSP	31	Housing Assy (3P, Yellow)	VKP2046
	2	BISB Assy	VWG1558		32	FG Assy	VWG1556
	3	Screw	BBZ30P060FMC		33	FG Base	VNL1781
	4	•••••			34	Tilt Cam	VNL1643
	5	Rack (Upper)	VNL1679		35	Tilt Cam Spring	VBH1243
	6	Shaft Stay	VNL1671		36	Screw	PMA30P050FMC
	7	Carriage Shaft (upper)	VLL1478		37	Screw	IBZ26P120FMC
	8	B Cam	VNL1673		38	Motor Base	VNE1941
	9	Shaft Support	VNL1672		39	•••••	
	10	Support Spring	VBH1265		40	Spindle Motor Assy	VXA2271
	11	SW Lever (B)	VNL1678		41	PRC Hub	VNL1684
	12	Large hill	VNL1682		42	Centering Spring	VBH1269
	13	Flexible Cable (23P)	VDA1528		43	R Turn Table Assy	VXA2225
	14	Turn Guide	VNL1701		44	•••••	
	15	FFC Style Shaft	VLL1474		NSP	45	Spindle Motor
NSP	16	Guide	VNL1674	46	•••••		
	17	Lever Spring	VBH1266	47	•••••		
	18	Turn Gear	VNL1702	48	Screw	IBZ26P060FMC	
	19	SW Lever (T)	VNL1695	49	Screw	BPZ20P040FZK	
	20	TNSB Assy	VWG1557	50	Housing Assy (2P, Red)	VKP2060	
	21	Housing Assy (3P, Black)	VKP2059	NSP	51	Earth Lead Unit	DE007VF0
	22	Tilt Base (Under)	VNL1670	52	Carriage Shaft (Under)	VLL1493	
	23	TAN Guide	VNE1973	53	Body Guard	VNL1681	
	24	CA Rack	VNL1647	54	FFC Holder	VNL1706	
	25	FFC Style Spring	VBH1270	55	CA Guide	VNL1668	
NSP	26	Thrust Spring	VBH1245	56	TAN Spring (B)	VBH1264	
	27	CA - SW Lever	VNL1644	57	TAN Lever (B)	VNL1669	
	28	PKSB Assy	VWG1555	58	Screw	PMZ20P060FZK	
	29	Housing Assy (3P, Blue)	VKP2045	59	Carriage Assy	VWT1110	
	30	Tilt Spring	VBH1263	NSP	60	Cord Binder	ZCB-069Z
				61	Screw	BBZ30P080FMC	

2.7 LOADING MECHANISM SECTION

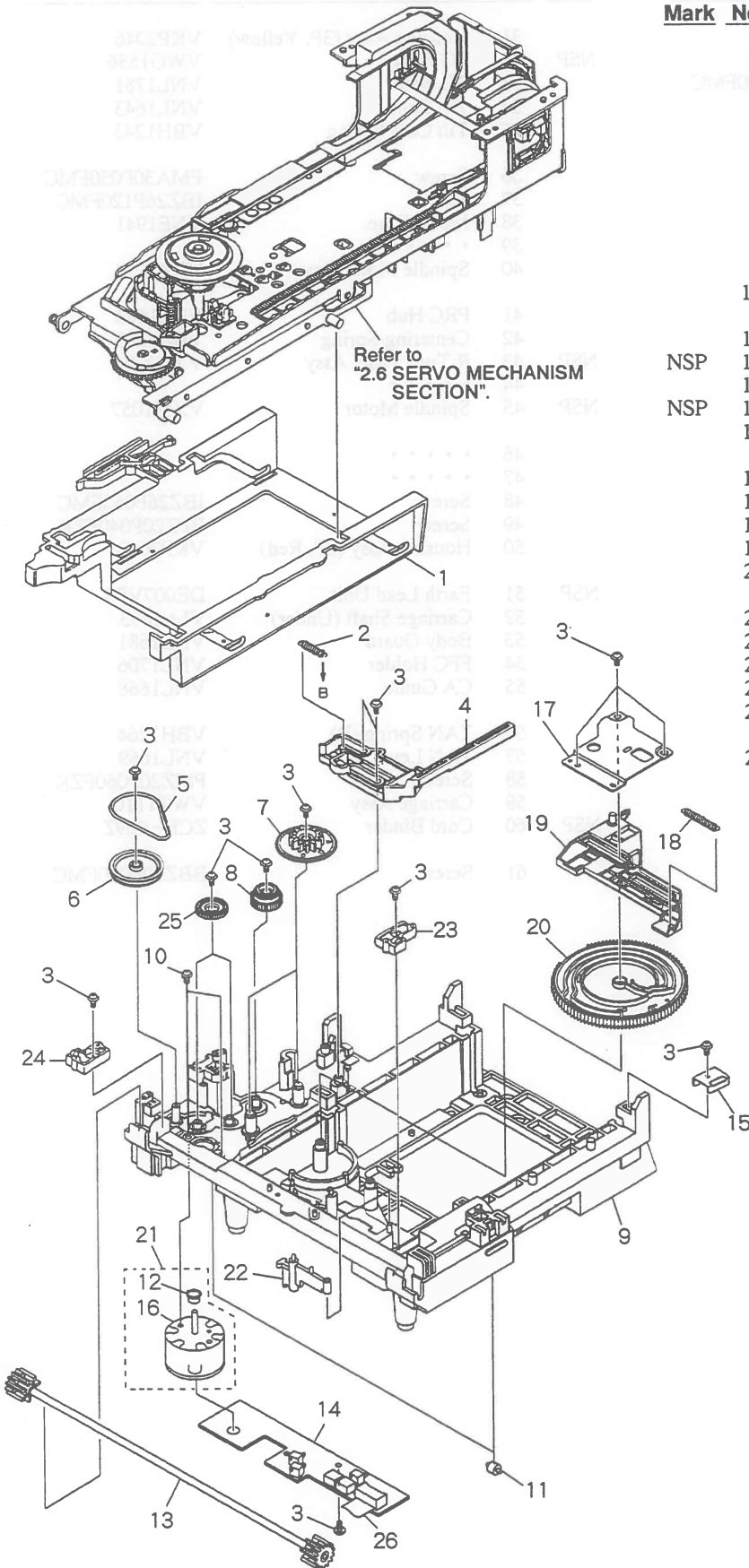

Parts List

Mark	No.	Description	Part No.
	1	Clamp Cam	VNL1633
	2	CDP Spring	VBH1191
	3	Screw	Z39-019
	4	CD Plate	VNL1685
	5	Rubber Belt	VEB1184
	6	Gear Pulley	VNL1662
	7	Twin Gear	VNL1626
	8	Center Gear	VNL1660
	9	Mechanism Base	VNK3239
	10	Screw	BMZ26P040FMC
NSP	11	Roller	VNL1042
	12	Motor Pulley	VNL1630
	13	Synchro Gear Assy	VXA2105
NSP	14	LMSB Assy	VWG1612
	15	Cam Holder	VNE2032
	16	Carriage Motor	VXM1033
	17	Shaft Holder	VNE1942
	18	CAS Spring	VBH1190
	19	Cam Plate	VNL1631
	20	Cam Gear	VNL1625
	21	Loading Motor Assy	VXX2045
	22	MB - SW Lever	VNL1664
	23	Slider (R)	VNL1666
	24	Slider (L)	VNL1665
	25	Double Gear	VNL1661
	26	Flexible Cable (12P)	VDA1485

2.8 CARRIAGE ASSY

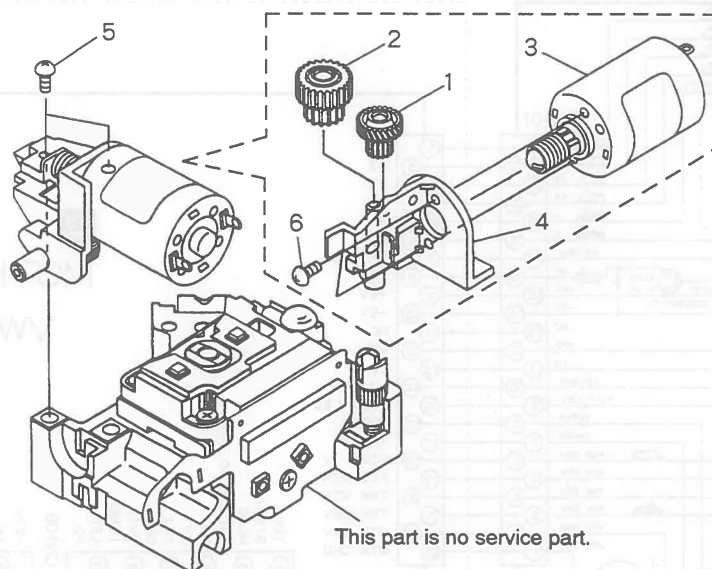

This part is no service part.

Parts List

Mark No.	Description	Part No.
1	CA Gear (A)	VNL1638
2	CA Gear (B)	VNL1639
3	Slider Motor Assy	VXX2082
4	M Holder	VNL1700
5	Screw	PBZ20P060FMC
6	Screw	PMZ20P030FMC

3. SCHEMATIC DIAGRAMS

3.1 OVERALL CONNECTIONS, PKSB, FG, TNSB, BISB, LMSB AND CARRIAGE ASSEMBLIES

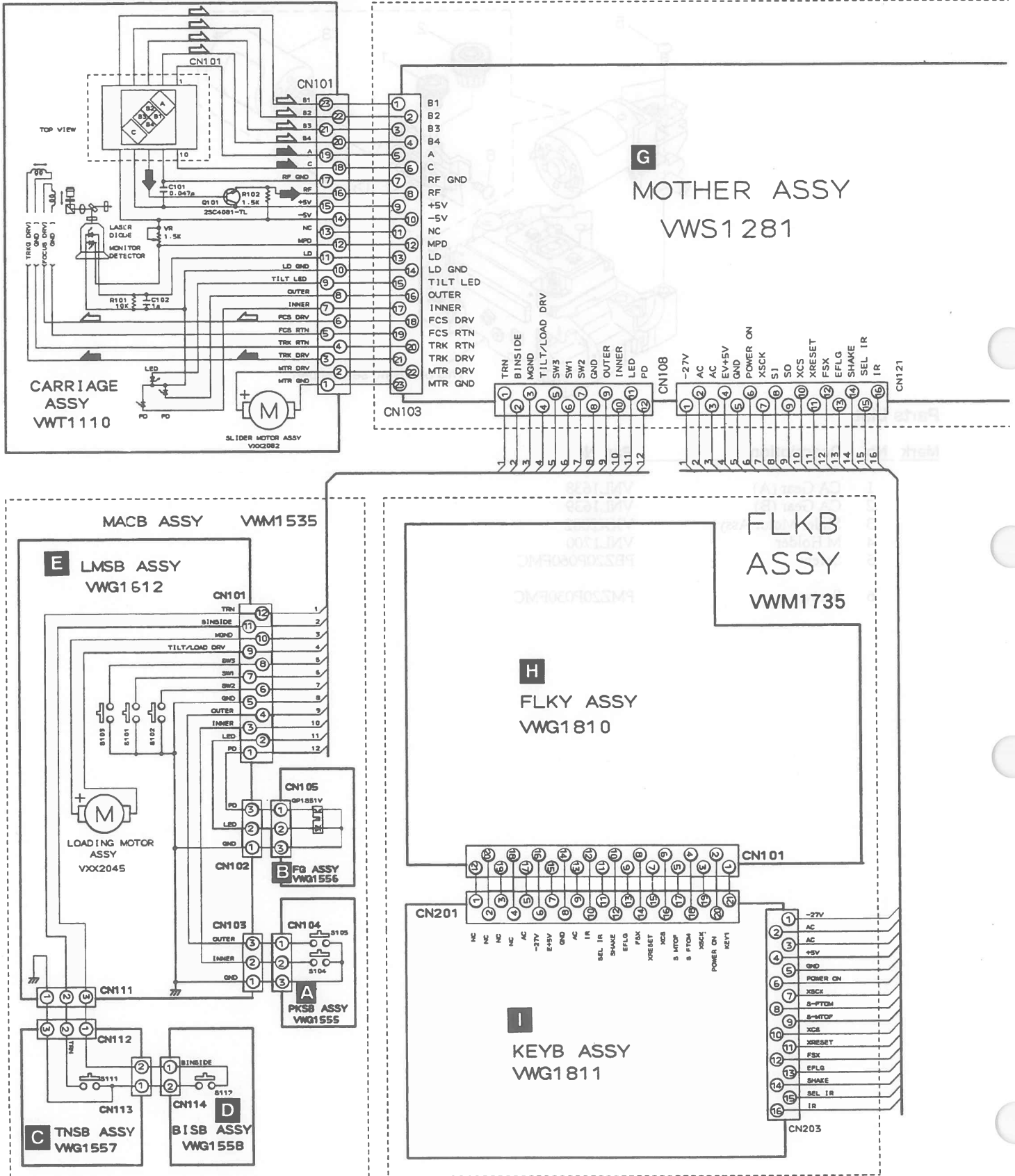

NOTE FOR SCHEMATIC DIAGRAMS

(Type 4A)

1. When ordering service parts, be sure to refer to "PARTS LIST of EXPLODED VIEWS" or "PCB PARTS LIST".

2. Since these are basic circuits, some parts of them or the values of some components may be changed for improvement.

3. RESISTORS:

Unit: k Ω , M:M Ω , or Ω unless otherwise noted.
 Rated power: 1/4W, 1/6W, 1/8W, 1/10W unless otherwise noted.
 Tolerance:(F): $\pm 1\%$, (G): $\pm 2\%$, (K): $\pm 10\%$, (M): $\pm 20\%$ or $\pm 5\%$ unless otherwise noted.

4. CAPACITORS:

Unit : p:F or μ F unless otherwise noted.
 Ratings : capacitor (μ F) /voltage (V) unless otherwise noted.
 Rated voltage : 50V except for electrolytic capacitors.

5. COILS:

Unit : m:mH or μ H unless otherwise noted.

6. VOLTAGE AND CURRENT:

or \leftarrow V :
 DC voltage (V) in PLAY mode unless otherwise noted.
 \leftrightarrow mA or \leftarrow mA :
 DC current in PLAY mode unless otherwise noted.
 Value in () is DC current in STOP mode.

7. OTHERS:

- or ○ : Adjusting point.
- ◀ : Measurement point.
- The Δ mark found on some component parts indicates the importance of the safety factor of the parts. Therefore, when replacing, be sure to use parts of identical designation.

8. SWITCHES (Underline indicates switch position):

- | | |
|-----------------------------------|---------------|
| FLKY ASSY | LMSB ASSY |
| S301 : DISPLAY OFF | S101:SW1 |
| S302 : QUICK TURN | S102:SW2 |
| S303 : POWER STANDBY/ON | S103:SW3 |
| KEYB ASSY | PKSB ASSY |
| S201 : STOP (■) | S104:INNER |
| S202 : ◀◀ ◀◀ | S105:OUTER |
| S203 : A (DISC SIDE) | TNSB ASSY |
| S204 : CD OPEN/CLOSE (Δ) | S111:TURN |
| S205 : LD OPEN/CLOSE (Δ) | BISB ASSY |
| S206 : B (DISC SIDE) | S112:B INSIDE |
| S207 : ▶▶ ▶▶ | |
| S208 : PLAY/PAUSE (▶ /) | |

9. View point of Large size SCH diagram :

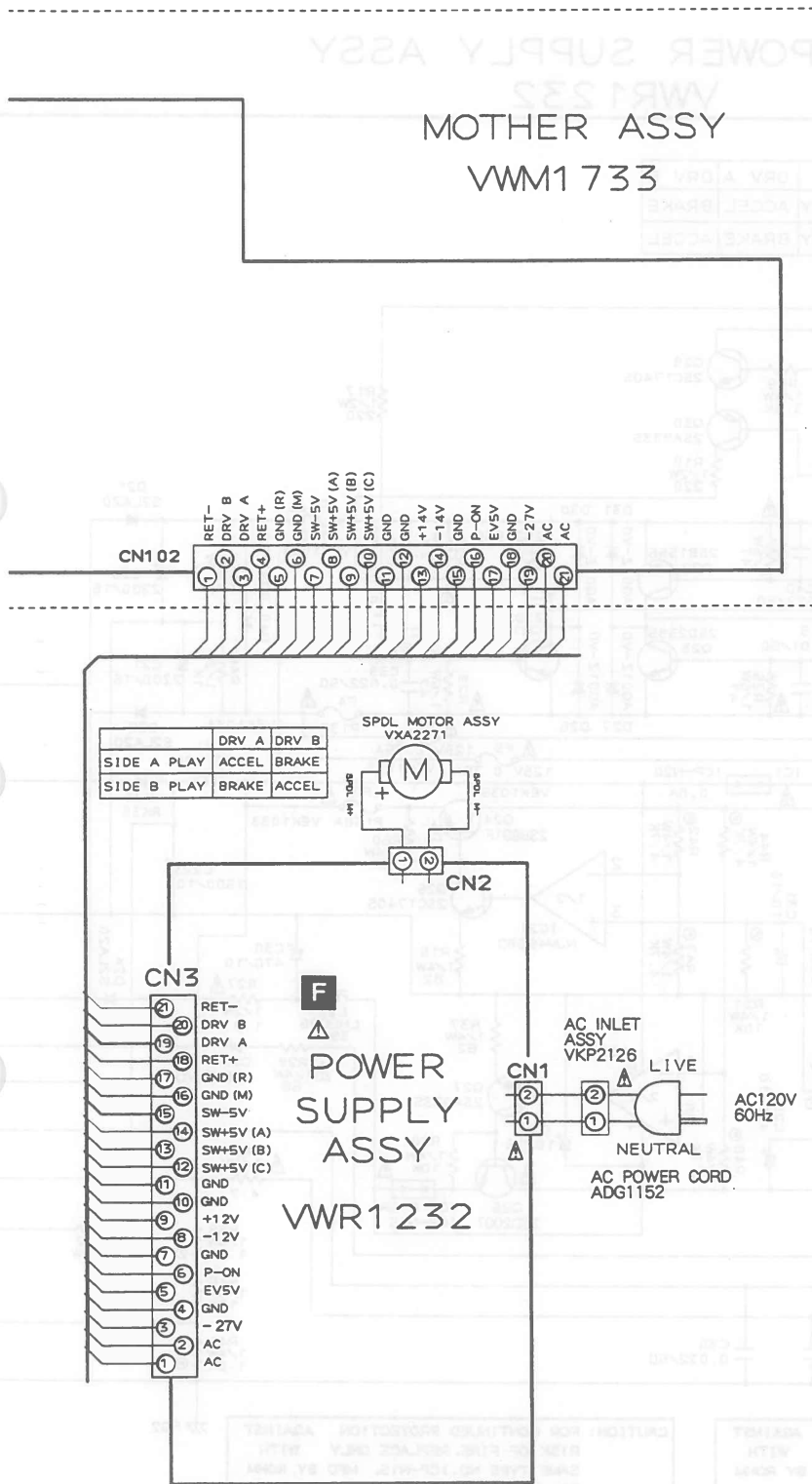
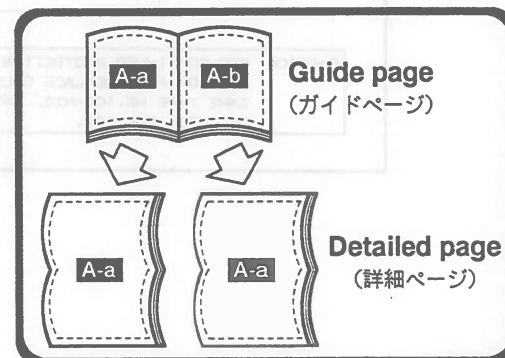
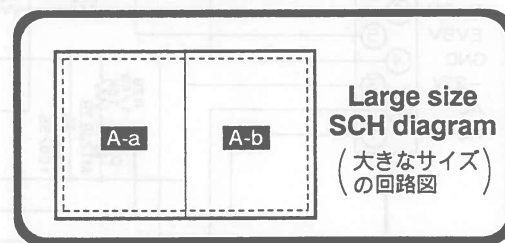

SIGNAL ROUTE

- ➡: RF SIGNAL ROUTE
- ⇄: FOCUS SERVO LOOP LINE
- ➡: TRACKING SERVO LOOP LINE

3.2 POWER SUPPLY ASSY

F Δ POWER SUPPLY ASSY
VWR1232

SPDL MOTOR ASSY
VXA2271

	DRV A	DRV B
SIDE A PLAY	ACCEL	BRAKE
SIDE B PLAY	BRAKE	ACCEL

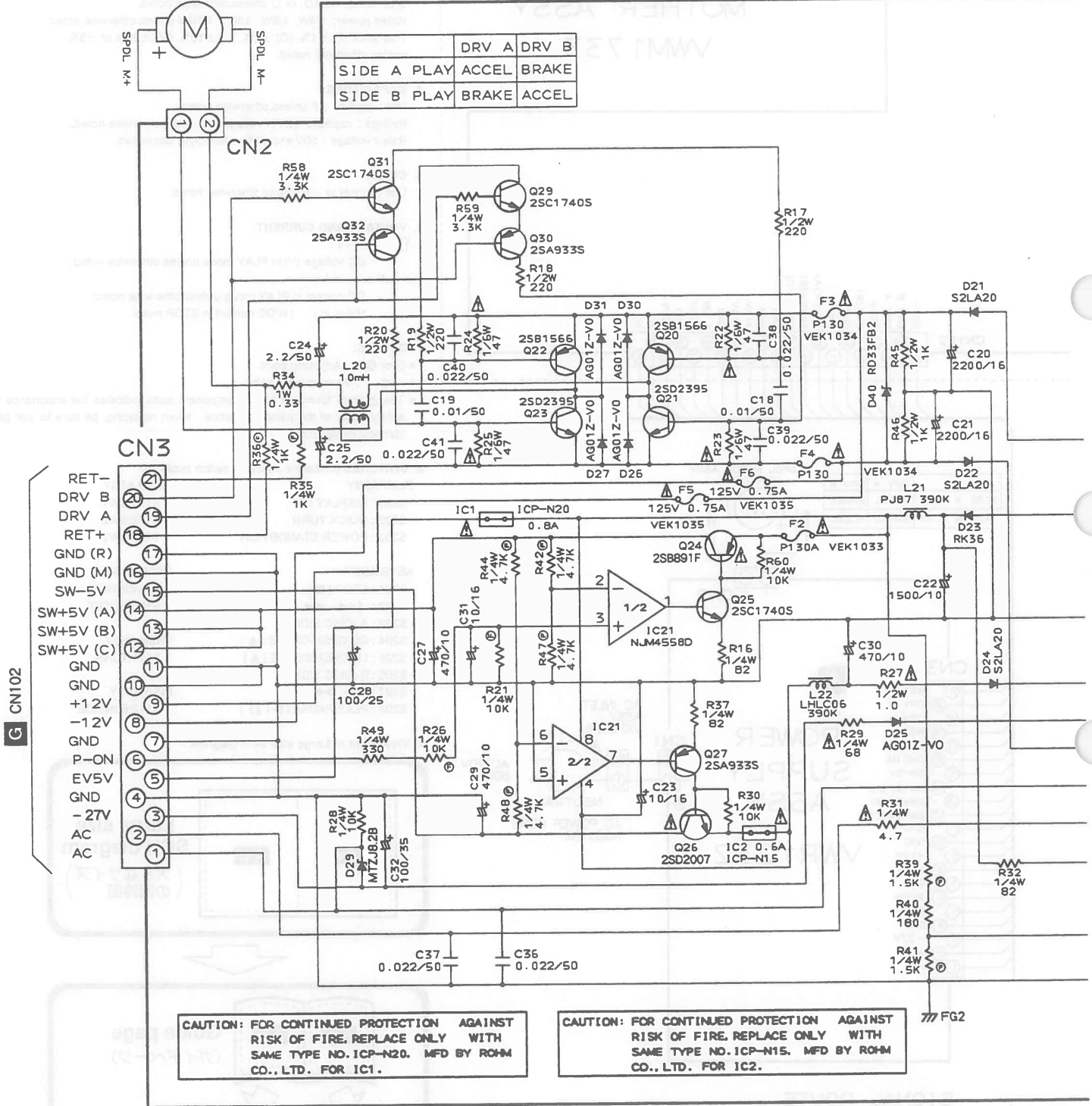

CAUTION: FOR CONTINUED PROTECTION AGAINST RISK OF FIRE, REPLACE ONLY WITH SAME TYPE NO. ICP-N20. MFD BY ROHM CO., LTD. FOR IC1.

CAUTION: FOR CONTINUED PROTECTION AGAINST RISK OF FIRE, REPLACE ONLY WITH SAME TYPE NO. ICP-N15. MFD BY ROHM CO., LTD. FOR IC2.

《NOTE OF SPARE PARTS IN POWER SUPPLY (SYPS) ASSY》

- In case of repairing, use the described parts only to prevent an accident.
- Please write the red ✓ mark on the board when the primary section of POWER SUPPLY (SYPS) Assy is repaired.
- Please take care to keep the space, not touching other parts when replacing the parts.

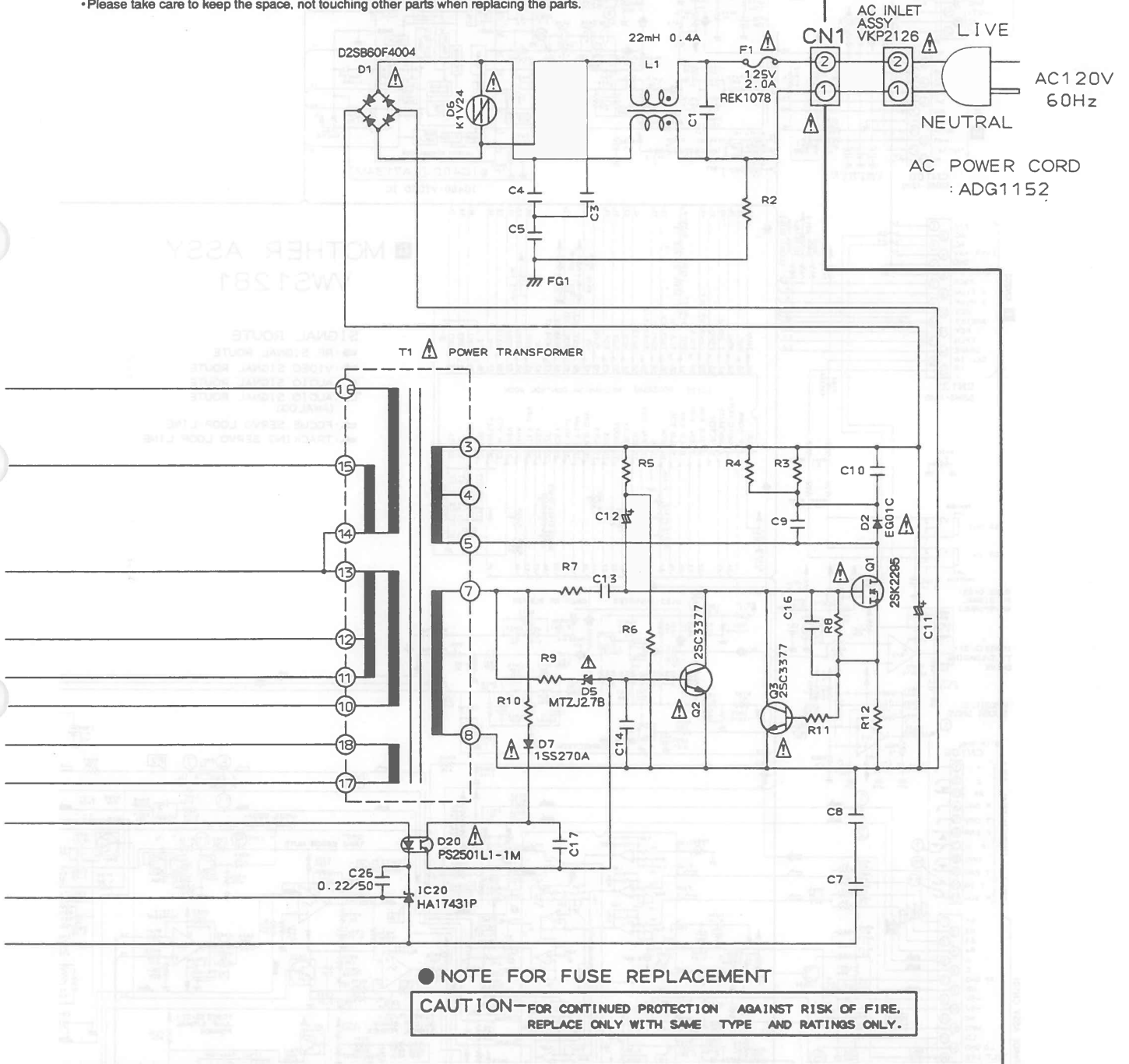

● NOTE FOR FUSE REPLACEMENT

CAUTION—FOR CONTINUED PROTECTION AGAINST RISK OF FIRE, REPLACE ONLY WITH SAME TYPE AND RATINGS ONLY.

3.3 MOTHER ASSY

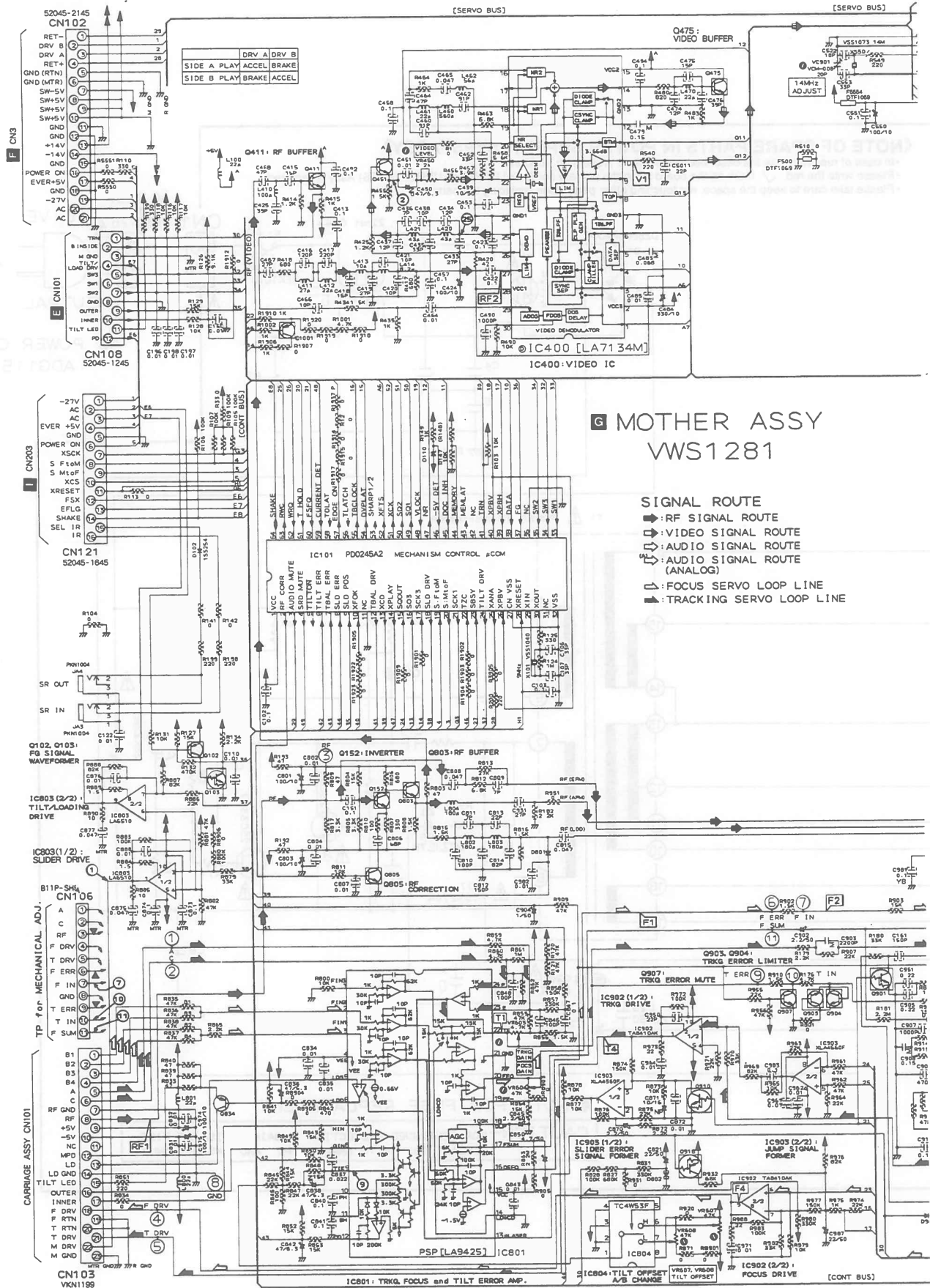

G MOTHER ASSY
WVS1281

- SIGNAL ROUTE**
- ▶: RF SIGNAL ROUTE
 - ◻: VIDEO SIGNAL ROUTE
 - ◻: AUDIO SIGNAL ROUTE
 - ◻: AUDIO SIGNAL ROUTE (ANALOG)
 - ◻: FOCUS SERVO LOOP LINE
 - ◻: TRACKING SERVO LOOP LINE

G-b

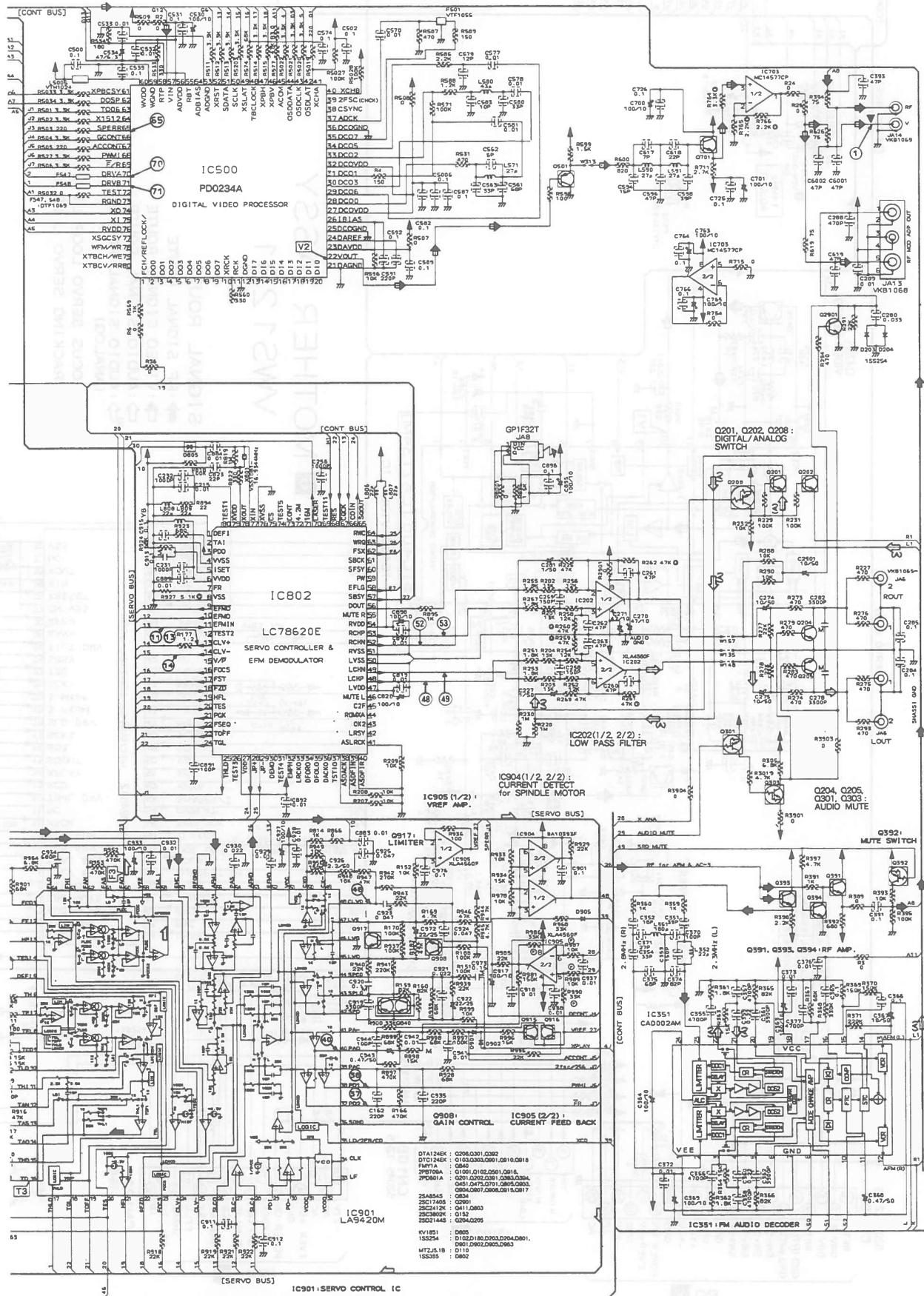

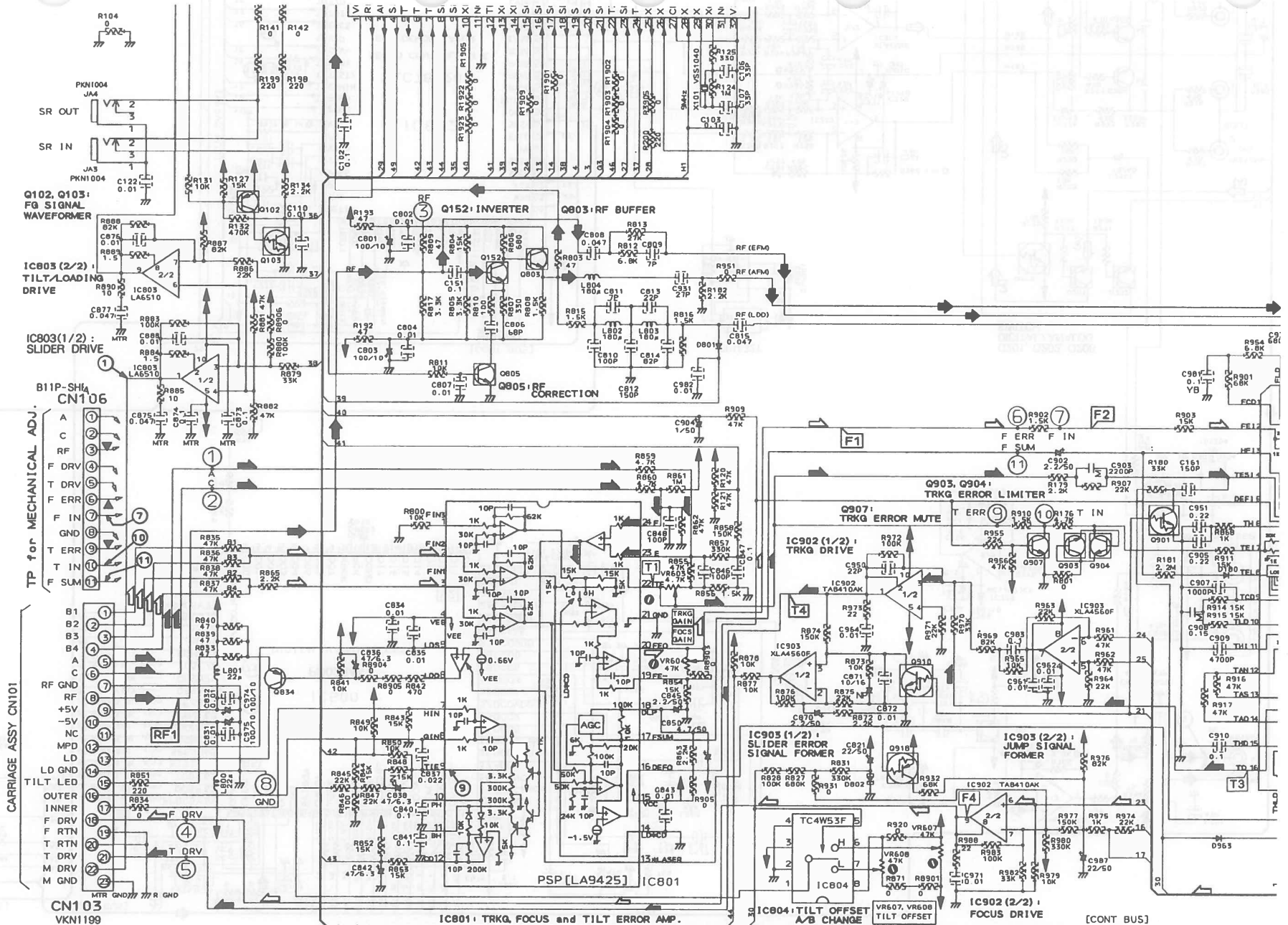

IC801: TRKG, FOCUS and TILT ERROR AMP.

IC804: TILT OFFSET A/B CHANGE

IC902 (2/2): FOCUS DRIVE

[CONT BUS]

WAVEFORMS AND VOLTAGE OF THE MOTHER ASSY

Note : (No.) in the table correspond to the pin number.

Measurement condition : In case when (D. audio) is written, at time when disc that has digital audio recording is played.

MOTHER ASSY					
IC801 (LA9425)	IC901 (LA9420M)	CN106	IC701 (CXD2046Q)	IC400 (LA7134M)	IC500 (PD0234A)
T1(22) 5ms/div 200mVp-p 0V DC mode	T3(19) 5ms/div 500mVp-p 0V DC mode	⑦ (F2) 5ms/div 200mVp-p 0V DC mode	⑳ 10 μsec/div 2.2Vp-p DC mode	V1(10) 10μs/div 1.6Vp-p 0V DC mode	V2(22) 10μs/div 1Vp-p DC mode
F1(20) 5ms/div 100mVp-p 0V DC mode	F3(60) 5ms/div 1Vp-p 0V DC mode	⑩ 5ms/div 100mVp-p 0V DC mode	⑳ 10 μsec/div 1Vp-p —GND DC mode	RF2(27) 2ms/div 400mVp-p AC mode	⑥⑤ 5ms/div 5Vp-p 0V DC mode
⑨ 10ms/div 0.2Vp-p 0V DC mode	⑳ 10μs/div 5Vp-p 0V DC mode	⑪ 5ms/div 0V 0.2Vp-p DC mode	⑳ 10 μsec/div 2.2Vp-p DC mode	⑳ 10μs/div 1Vp-p 0V DC mode	⑦① 10μs/div 5Vp-p 0V DC mode
IC802 (LC78620E)	④① 10ms/div 0.3Vp-p 0V DC mode	CN103		Q451 Emitter	
⑪ 0.5μs/div 1.6Vp-p 0V DC mode	④⑧ 50μs/div 1Vp-p 0V DC mode	RF1(8) 2ms/div 600mVp-p AC mode		② 10μs/div 400mVp-p AC mode	
⑬ 50μs/div 5Vp-p 0V DC mode	IC902 (TA8410AK)			JA14 VIDEO OUT	
⑭ 50μs/div 5Vp-p 0V DC mode	T4(1) 5ms/div 2Vp-p 0V DC mode			① 10μs/div 1Vp-p (75Ω termination) 0V DC mode	
④⑧(53) 0.2μs/div 5Vp-p 0V DC mode					
④⑨(52) 0.2μs/div 5Vp-p 0V DC mode					
IC803 (LA6510)	F4(9) 5ms/div 5Vp-p 0V DC mode				
① 2ms/div 1.8Vp-p 0V DC mode					

3.4 FLKY AND KEYB ASSEMBLIES

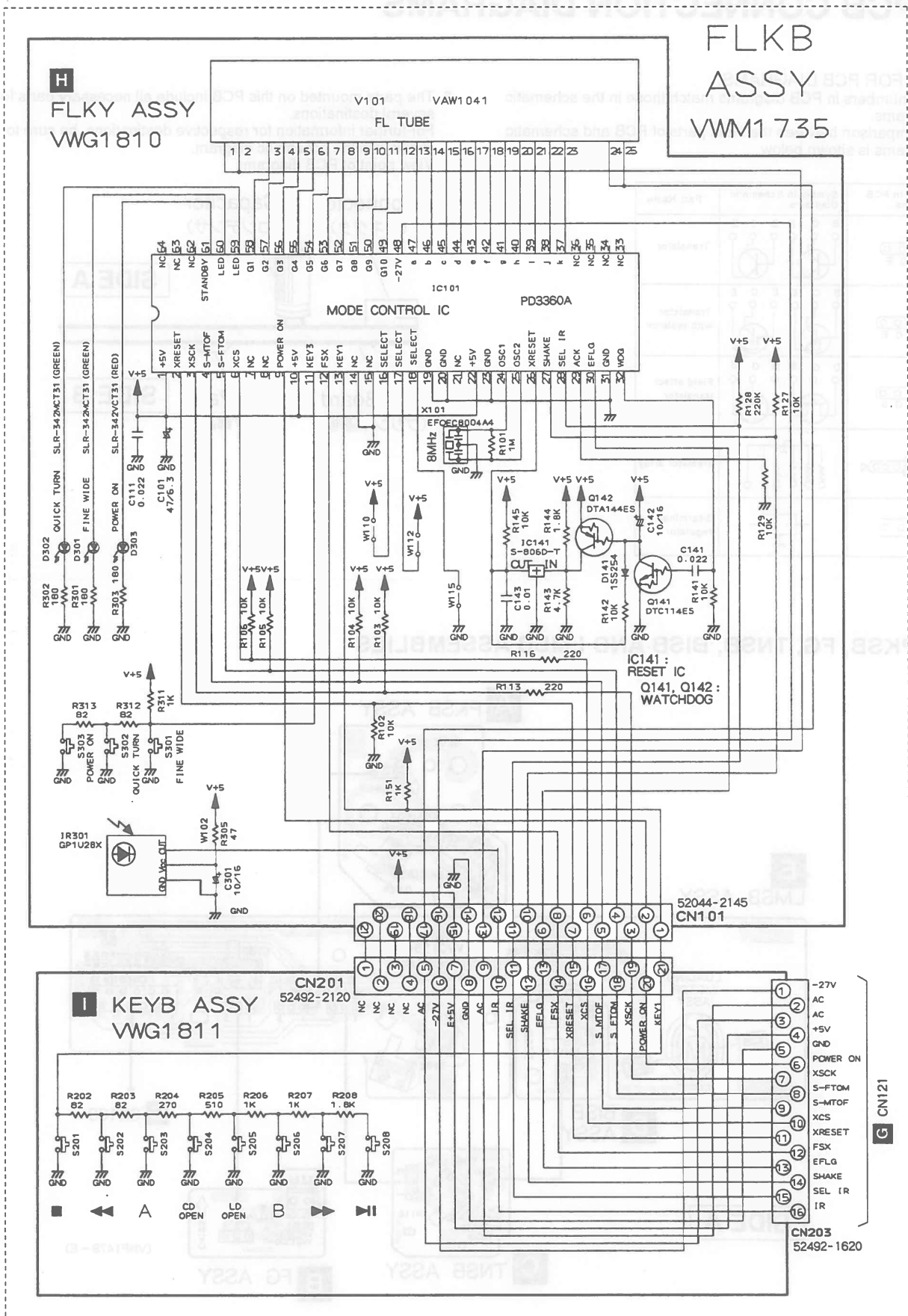

4. PCB CONNECTION DIAGRAMS

NOTE FOR PCB DIAGRAMS:

1. Part numbers in PCB diagrams match those in the schematic diagrams.
2. A comparison between the main parts of PCB and schematic diagrams is shown below.
3. The parts mounted on this PCB include all necessary parts for several destinations.
4. View point of PCB diagrams

Symbol In PCB Diagrams	Symbol In Schematic Diagrams	Part Name
		Transistor
		Transistor with resistor
		Field effect transistor
		Resistor array
		3-terminal regulator

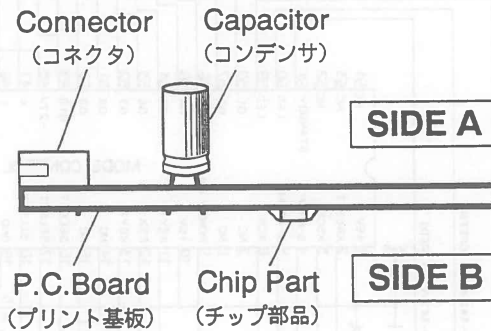

4.1 PKSB, FG, TNSB, BISB AND LMSB ASSEMBLIES

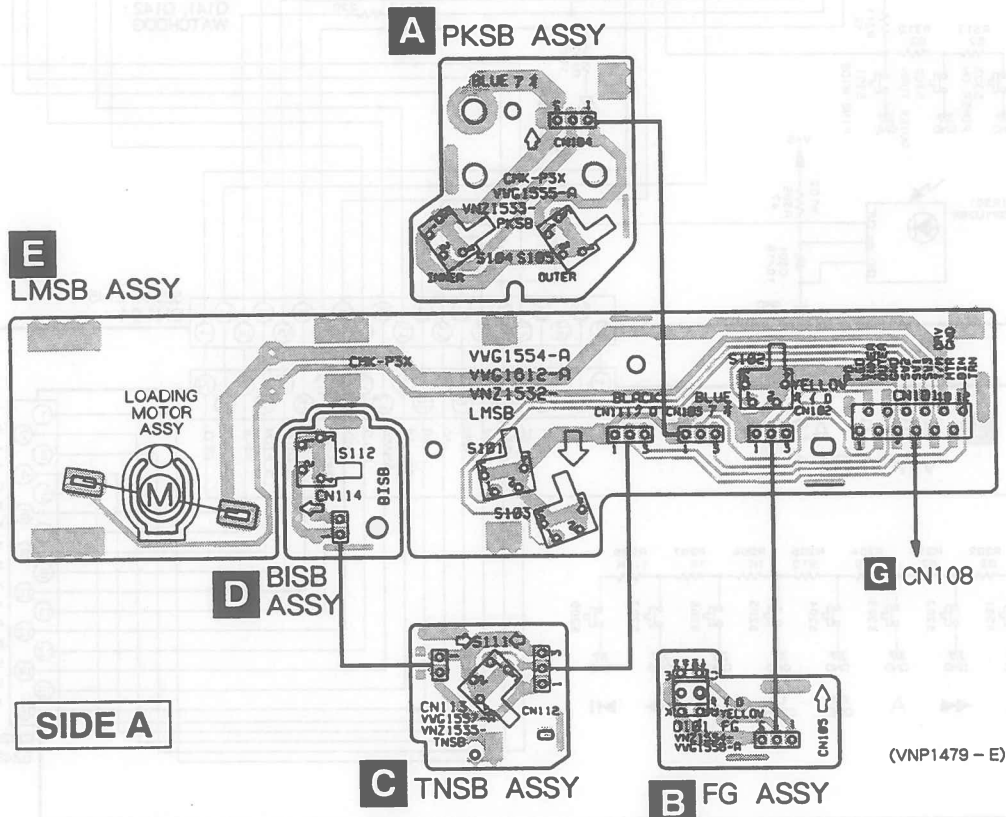

4.2 POWER SUPPLY ASSY

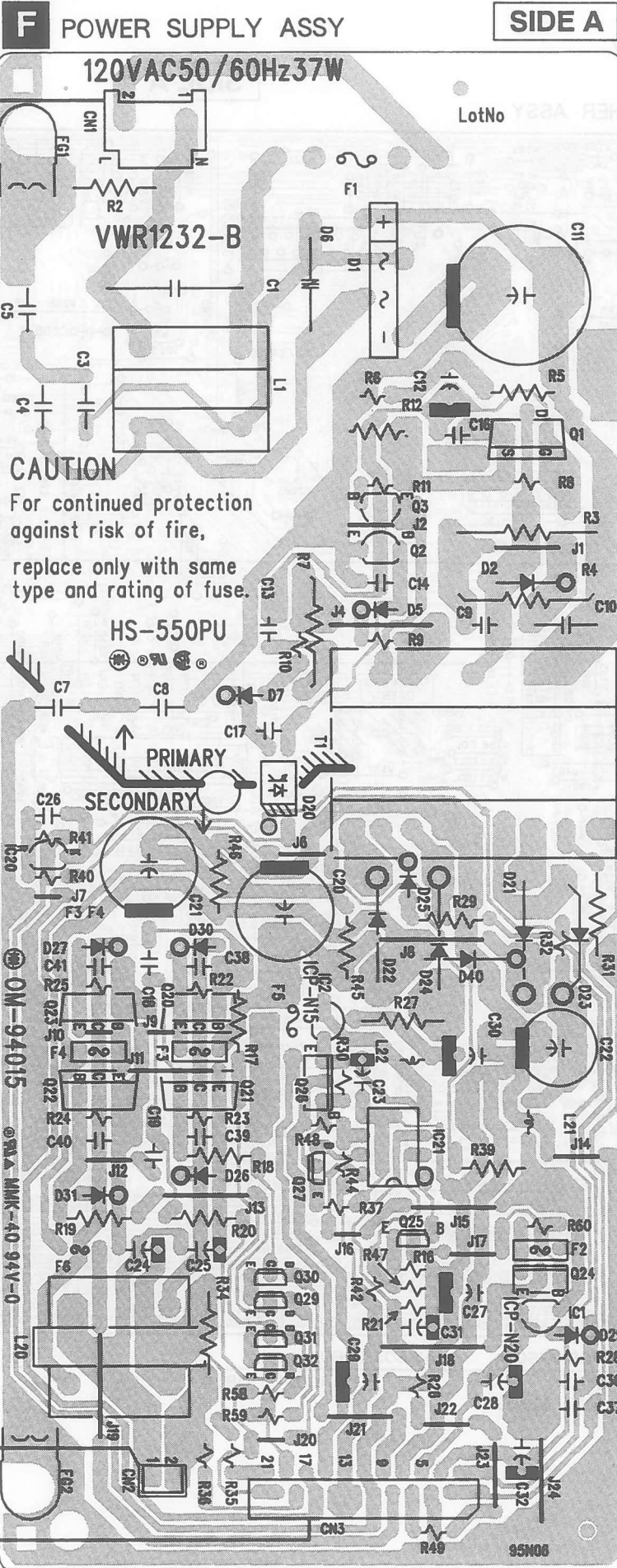

G CN102

4.3 MOTHER ASSY

SIDE A

G MOTHER ASSY

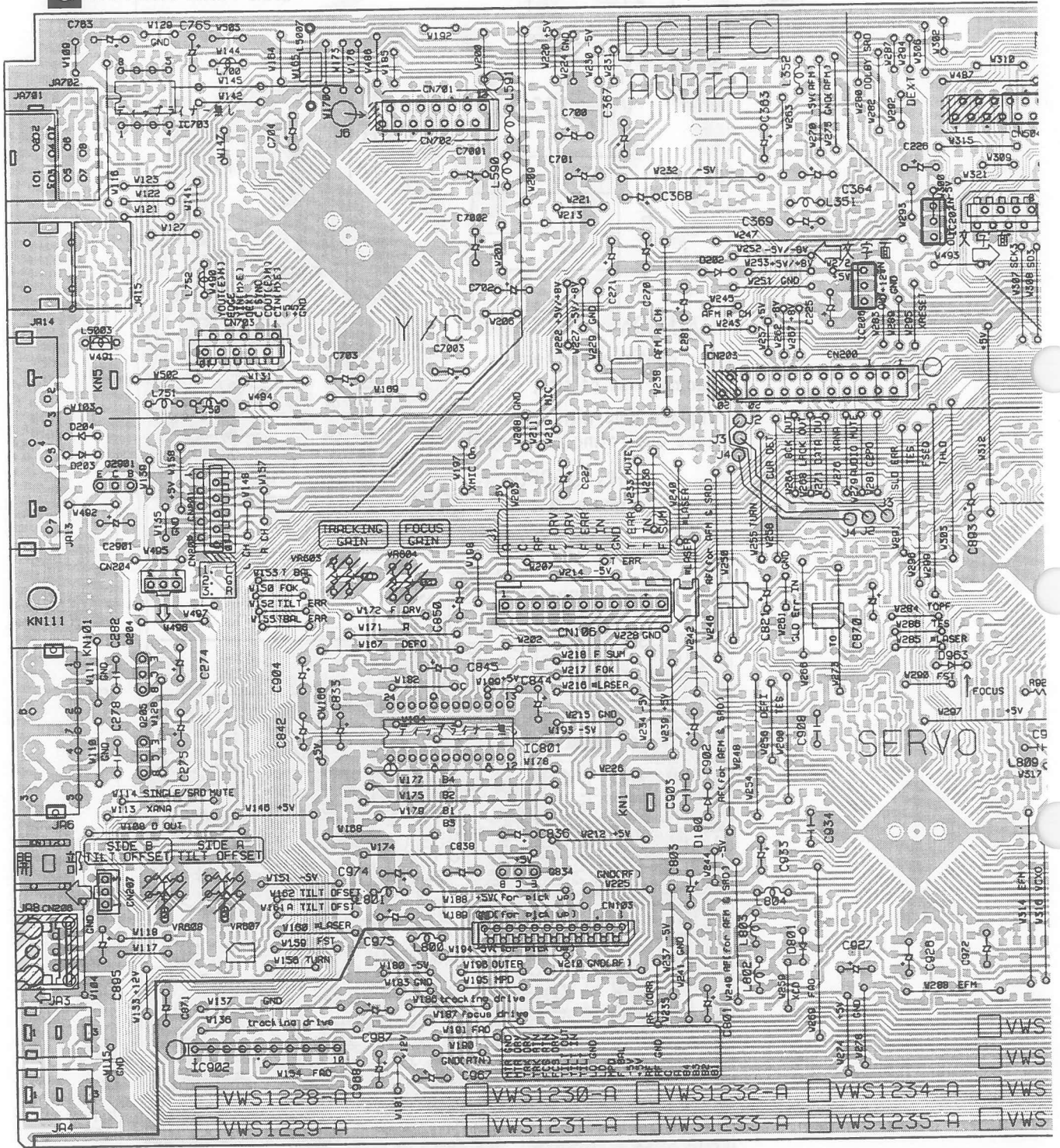

CARRIAGE ASSY CN101	VR608 VR607	VR603 VR604	IC801	Q834	IC206	IC207
	Q2901 IC703					
	Q204 Q205	IC902				

SIDE B

G MOTHER ASSY

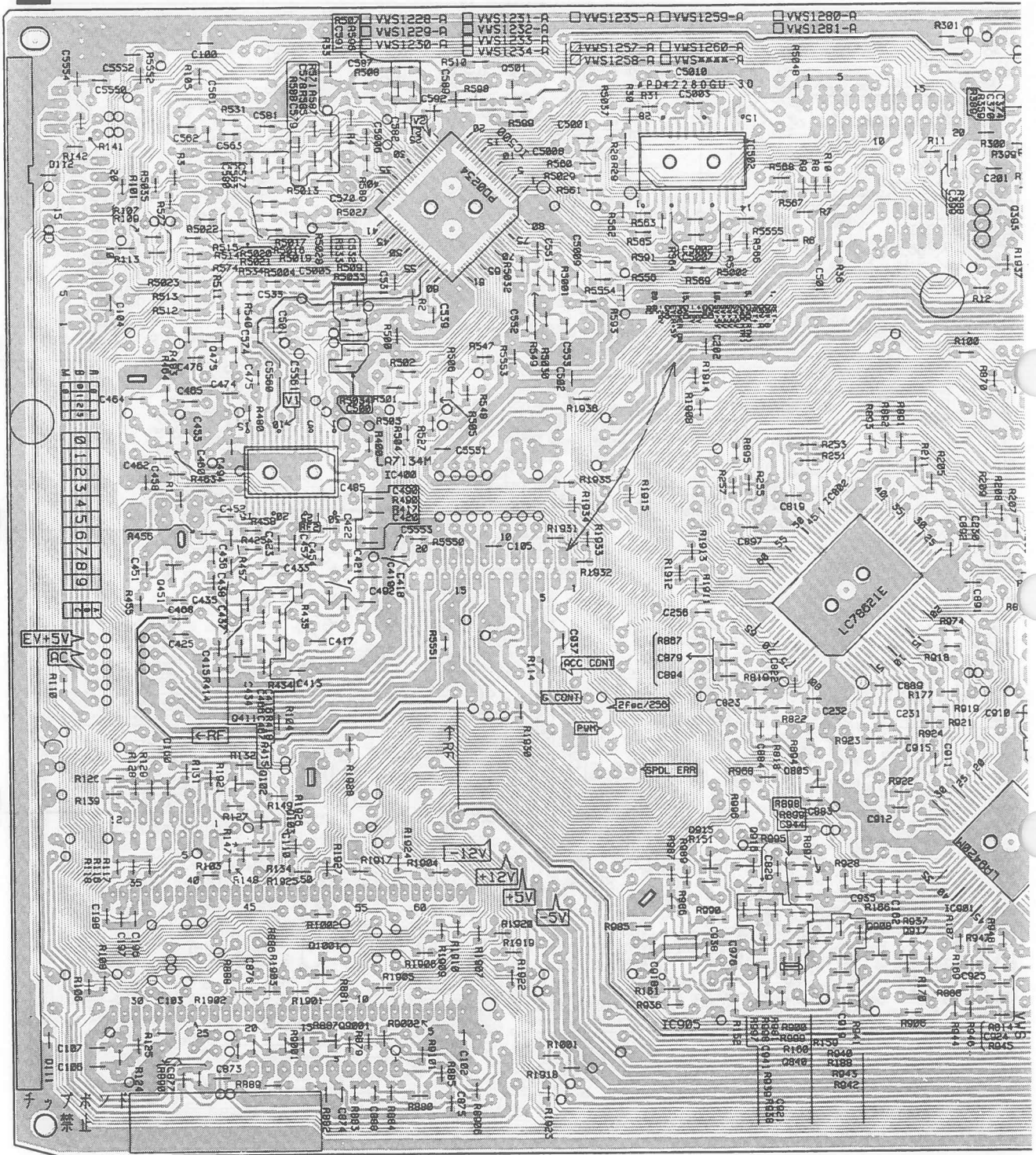

Q451 Q475 Q411 IC400 IC500 Q501 IC502 IC802 Q39
 Q102 Q103 Q1001 IC905 Q915 Q916 Q840 Q908 Q917 IC901
 Q9001



44 FLKY AND KEY ASSEMBLIES

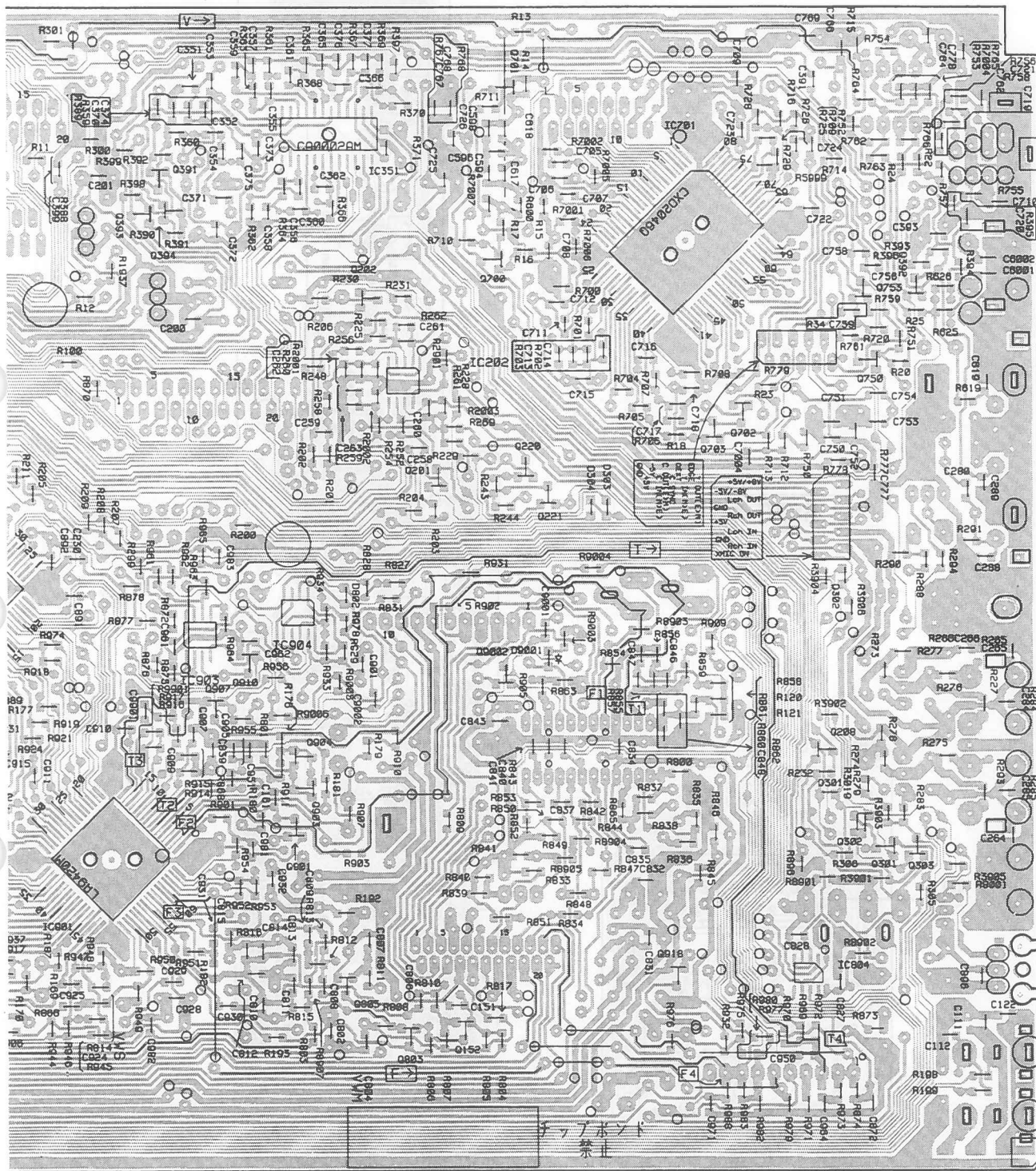

(VNP1554 - E)

Q393	Q394	Q391	IC351	Q202	IC202	Q700	Q701	IC701	Q703	Q702	Q753	Q392	
Q917	IC901	IC903	Q910	IC904	Q904	Q201	Q9002	Q220	Q918	IC804	Q301-Q303	Q208	Q750
	Q907	Q901	Q903	Q805	Q803	Q152	Q221						

5. PCB PARTS LIST

NOTES: ● Parts marked by "NSP" are generally unavailable because they are not in our Master Spare Parts List.

● The Δ mark found on some component parts indicates the importance of the safety factor of the part. Therefore, when replacing, be sure to use parts of identical designation.

● When ordering resistors, first convert resistance values into code form as shown in the following examples.

Ex.1 When there are 2 effective digits(any digit apart from 0), such as 560 ohm and 47k ohm(tolerance is shown by J=5%, and K=10%).

560 Ω \rightarrow $56 \times 10^1 \rightarrow 561$ RD1/4PU **561**J

47k Ω \rightarrow $47 \times 10^3 \rightarrow 473$ RD1/4PU **473**J

0.5 Ω \rightarrow 0R5 RN2H **0R5**K

1 Ω \rightarrow 1R0 RSIP **1R0**K

Ex.2 When there are 3 effective digits(such as in high precision metal film resistors).

5.62k Ω \rightarrow $562 \times 10^1 \rightarrow 5621$ RNI/4PC **5621**F

Mark	No.	Description	Part No.
------	-----	-------------	----------

LIST OF ASSEMBLIES

NSP		MACB ASSY	VWM1535
NSP		└ PKSB ASSY	VWG1555
NSP		└ FG ASSY	VWG1556
NSP		└ TNSB ASSY	VWG1557
NSP		└ BISB ASSY	VWG1558
NSP		└ LMSB ASSY	VWG1612

Δ		POWER SUPPLY ASSY	VWR1232
----------	--	-------------------	---------

NSP		MOTHER ASSY	VWM1733
		└ MOTHER ASSY	VWS1281

NSP		FLKB ASSY	VWM1735
		└ FLKY ASSY	VWG1810
		└ KEYB ASSY	VWG1811

MACB ASSY

OTHERS

		PC BOARD MACB	VNP1479
--	--	---------------	---------

A PKSB ASSY

SWITCHES

		S104, S105	DSG1017
--	--	------------	---------

B FG ASSY

SEMICONDUCTOR

		D101	GP1S24
--	--	------	--------

C TNSB ASSY

SWITCH

		S111	DSG1017
--	--	------	---------

Mark	No.	Description	Part No.
------	-----	-------------	----------

D BISB ASSY

SWITCH

		S112	DSG1017
--	--	------	---------

E LMSB ASSY

SWITCHES

		S101-S103	DSG1017
--	--	-----------	---------

OTHERS

		CN101	12P FFC CONNECTOR	52044-1245
--	--	-------	-------------------	------------

F POWER SUPPLY ASSY

SEMICONDUCTORS

Δ		IC2	ICP-N15
Δ		IC1	ICP-N20
		IC20	HA17431P
		IC21	NJM4558D
		Q27, Q30, Q32	2SA933S

		Q20, Q22	2SB1566
Δ		Q24	2SB891F
		Q25, Q29, Q31	2SC1740S
Δ		Q2, Q3	2SC3377
Δ		Q26	2SD2007

		Q21, Q23	2SD2395
Δ		Q1	2SK2295
		D25-D27, D30, D31	AG01Z-V0
Δ		D1	D2SB60F4004
Δ		D2	EG01C

Δ		D6	K1V24
Δ		D5	MTZJ2. 7B
		D29	MTZJ8. 2B
Δ		D20	PS2501L1-1M
		D40	RD33FB2

CLD-D406

Mark	No.	Description	Part No.
	D23		RK36
	D21, D22, D24		S2LA20
△	D7		1SS270A

RESISTORS

△	R22-R25	(47Ω)	VCN1033
△	R27	(1Ω)	VCN1047
△	R29	(68Ω)	VCN1048
△	R31	(4.7Ω)	VCN1049

OTHERS

△	F1	FUSE(2A/125V)	REK1078
△	F2	FUSE	VEK1033
△	F3, F4	FUSE	VEK1034
△	F5, F6	FUSE(0.75A/125V)	VEK1035

MOTHER ASSY

OTHERS

PC BOARD MOTHER	VNP1554
-----------------	---------

G MOTHER ASSY

SEMICONDUCTORS

IC904	BA10393F
IC351	CA0002AM
IC803	LA6510
IC400	LA7134M
IC901	LA9420M
IC801	LA9425
IC802	LC78620E
IC703	MC14577CP
IC500	PD0234A
IC101	PD0245A2
IC902	TA8410AK
IC804	TC4W53F
IC202, IC903, IC905	XLA4560F
Q1001, Q102, Q501, Q916	2PB709A
Q201, Q202, Q391, Q393, Q394	2PD601A
Q451, Q475, Q701, Q805	2PD601A
Q903, Q904, Q907, Q908, Q915	2PD601A
Q917	2PD601A
Q834	2SA854S
Q2901	2SC1740S
Q411, Q803	2SC2412K
Q152	2SC3802K
Q204, Q205	2SD2144S
Q208, Q301, Q392	DTA124EK
Q103, Q303, Q901, Q910, Q918	DTC124EK
Q840	FMY1A
D102, D180, D203, D204, D801	1SS254
D901, D902, D905, D963	1SS254
D802	1SS355
D805	KV1851
D110	MTZJ5.1B

Mark	No.	Description	Part No.
------	-----	-------------	----------

COILS AND FILTERS

F500, F547, F548, F5554	CHIP BEAD	DTF1069
L413		LAU100J
L410		LAU101J
L351, L802-L804		LAU181J
L100, L352, L412, L461, L470		LAU220J
L800, L801, L806-L809		LAU220J
L411, L571, L590, L591		LAU270J
L420, L421, L580		LAU430J
L462		LAU560J
L414		LAU8R2J
L460		LFA561J
F501	14.3MHz FILTER	VTF1055
L5005	FERRITE BEAD	VTH1024

CAPACITORS

C562	CCSQCH050C50
C436, C617, C809, C811	CCSQCH070D50
C420, C421, C438, C466, C583	CCSQCH100D50
C370, C810, C846, C848, C891	CCSQCH101J50
C944	CCSQCH101J50
C434, C437, C474, C579	CCSQCH120J50
C416	CCSQCH121J50
C415, C418, C475, C594	CCSQCH150J50
C161, C258, C259, C353, C812	CCSQCH151J50
C352, C552	CCSQCH180J50
C5011, C618, C813, C823, C950	CCSQCH220J50
C162, C417, C591, C935	CCSQCH221J50
C371, C419, C433, C467, C931	CCSQCH270J50
C106, C107, C354, C435, C452	CCSQCH330J50
C553, C563, C580	CCSQCH330J50
C351, C425, C476, C598	CCSQCH390J50
C260-C263, C464, C468, C596	CCSQCH470J50
C6001, C6002, C619	CCSQCH470J50
C288	CCSQCH471J50
C375, C561, C806	CCSQCH680J50
C374, C814	CCSQCH820J50
C460, C462	CCSQCH910J50
C534, C836, C842	CEAL470M6R3
C450, C838	CEALNP470M6R3
C972	CEANP220M10
C227, C281, C904	CEAS010M50
C274, C275, C2901, C367, C439	CEAS100M50
C270, C271, C363, C364, C369	CEAS101M10
C424, C530, C550, C700, C701	CEAS101M10
C763, C765, C801, C803, C820	CEAS101M10
C895, C898, C917, C927, C933	CEAS101M10
C974, C975	CEAS101M10
C821, C922	CEAS220M25
C845, C870, C902, C926	CEAS2R2M50
C484	CEAS331M10
C368, C943	CEASR47M50
C987	CEHAQ220M50
C850	CEJA47M35
C256, C490, C907	CKSQYB102K50
C915, C981	CKSQYB104K25

6. ADJUSTMENTS (調整方法)

6.1 ADJUSTMENT ITEMS AND LOCATION (調整項目と調整位置)

■ Adjustment Points (PCB Part)

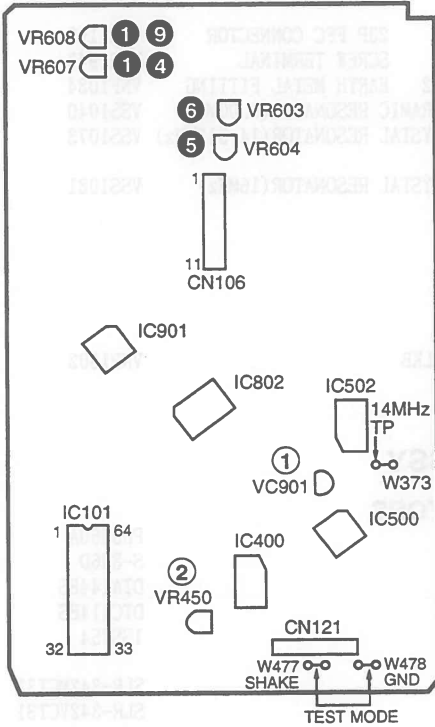

■ Adjustment Items

[Mechanical Part]

- ① Tilt Offset Adjustment (チルトオフセット調整)
- ② Tangential Direction Angle Adjustment for Side A (A面タンジェンシャル傾き調整)
- ③ Spindle Motor Centering Adjustment for Side A (A面スピンドル芯出し調整)
- ④ Crosstalk Check and Fine Tilt Offset Adjustment for Side A (A面クロストーク確認及び、チルトオフセット微調)
- ⑤ Focus Servo Loop Gain Adjustment (フォーカスサーボループゲイン調整)
- ⑥ Tracking Servo Loop Gain Adjustment (トラッキングサーボループゲイン調整)
- ⑦ Tangential Direction Angle Adjustment for Side B (B面タンジェンシャル傾き調整)
- ⑧ Spindle Motor Centering Adjustment for Side B (B面スピンドル芯出し調整)
- ⑨ Crosstalk Check and Fine Tilt Offset Adjustment for Side B (B面クロストーク確認及び、チルトオフセット微調)

[Electrical Part]

- ① Master Clock Adjustment (マスタークロック調整)
- ② Output Video Level Adjustment (出力ビデオレベル調整)

■ Adjustment Points (Mechanism Part)



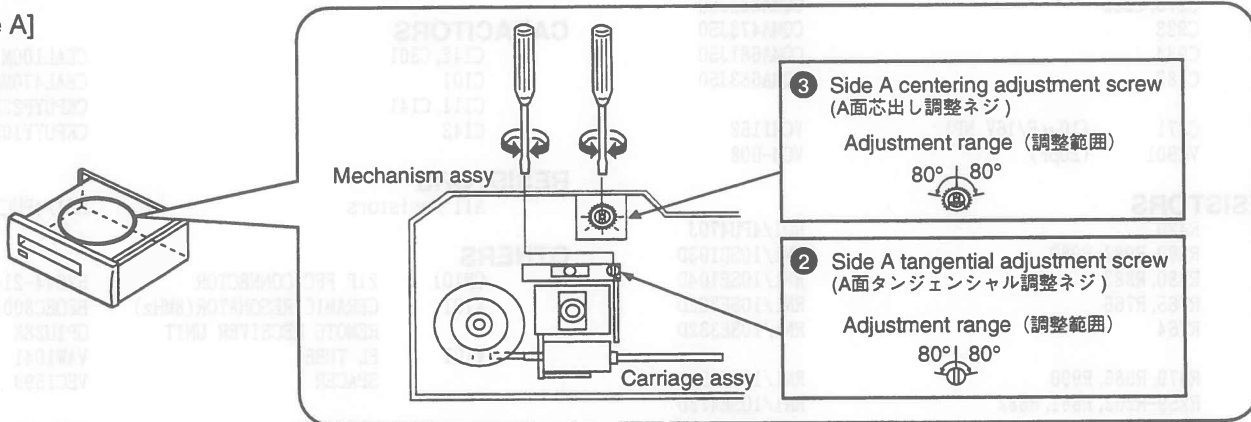



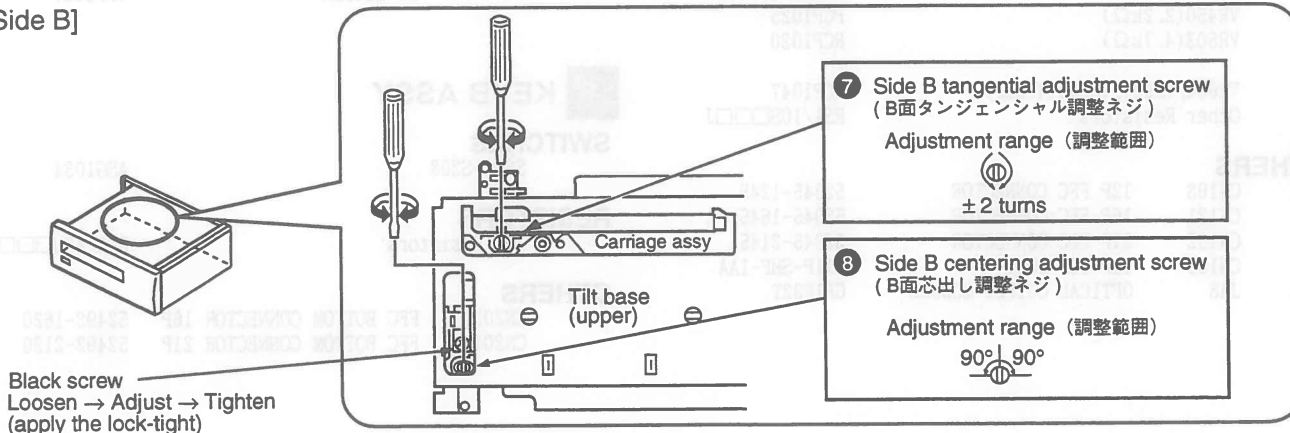

[Side A]



[Side B]

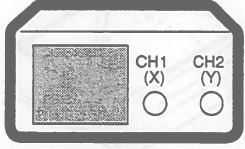

6.2 JIGS AND MEASURING INSTRUMENTS (調整に必要な治工具類)

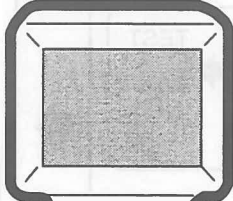
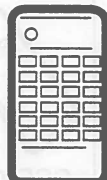
 <p>CD test disc (YEDS-7)</p>	 <p>LD test disc (GGV1012)</p>	 <p>⊖ Screwdriver (medium)</p>	 <p>⊖ Screwdriver (small)</p>
 <p>⊖ Precise screwdriver</p>	 <p>⊕ Screwdriver (large)</p>	 <p>⊕ Screwdriver (medium)</p>	 <p>Dual-trace oscilloscope (with delay) Frequency band $\geq 40\text{MHz}$</p>
 <p>Frequency counter Display digit $\geq 8\text{-digit}$</p>	 <p>TV monitor</p>	 <p>Test mode remote control unit (GGF1067)</p>	

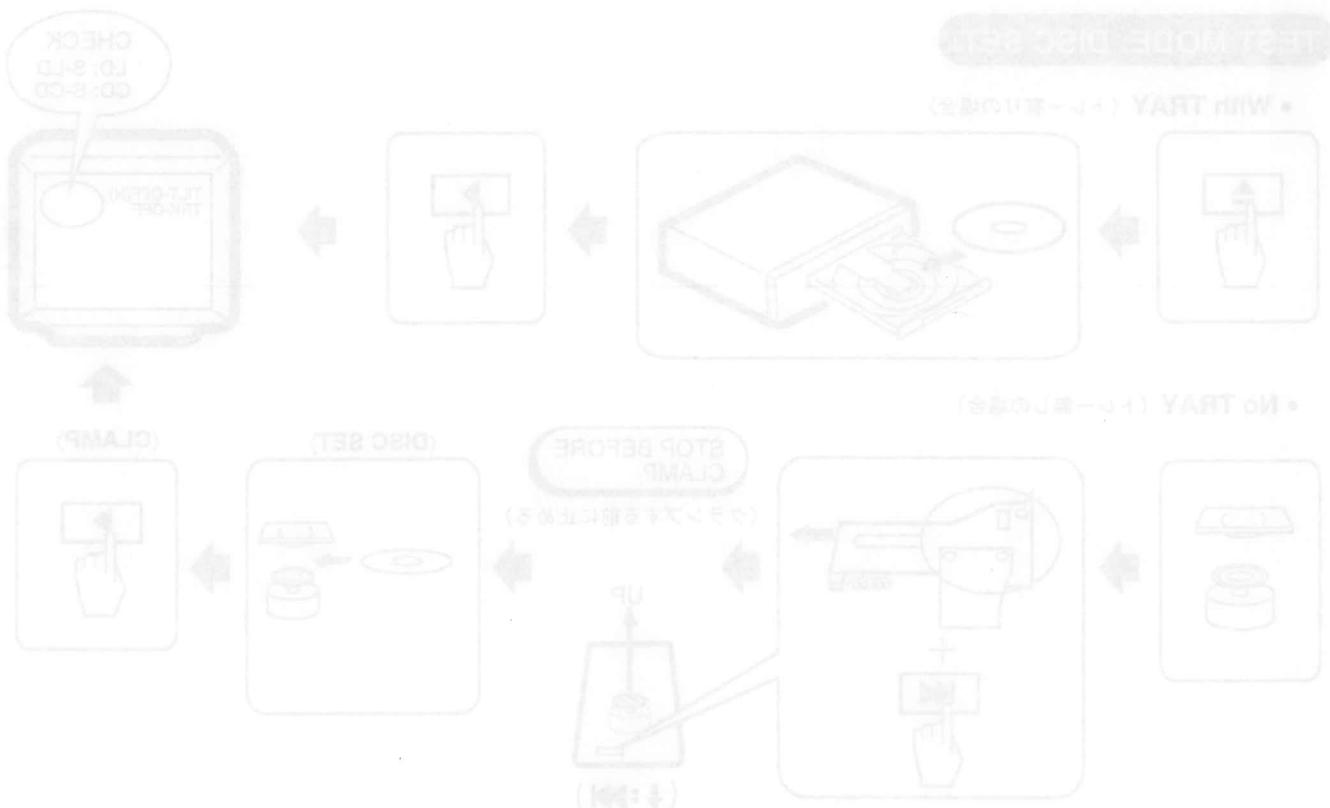

6.3 TEST MODE (テストモード)

TEST MODE: ON

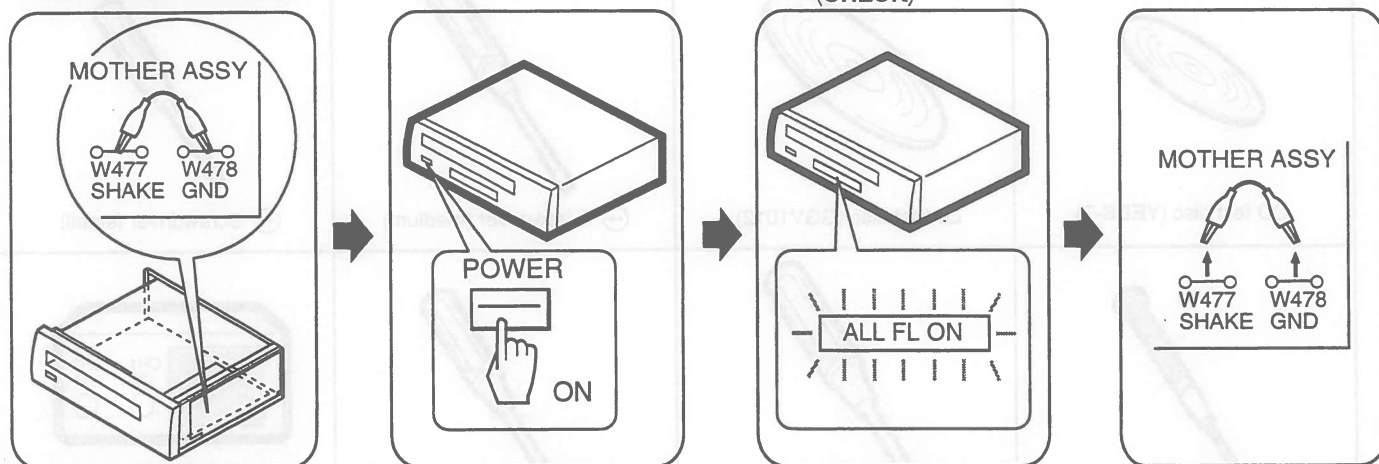

OR

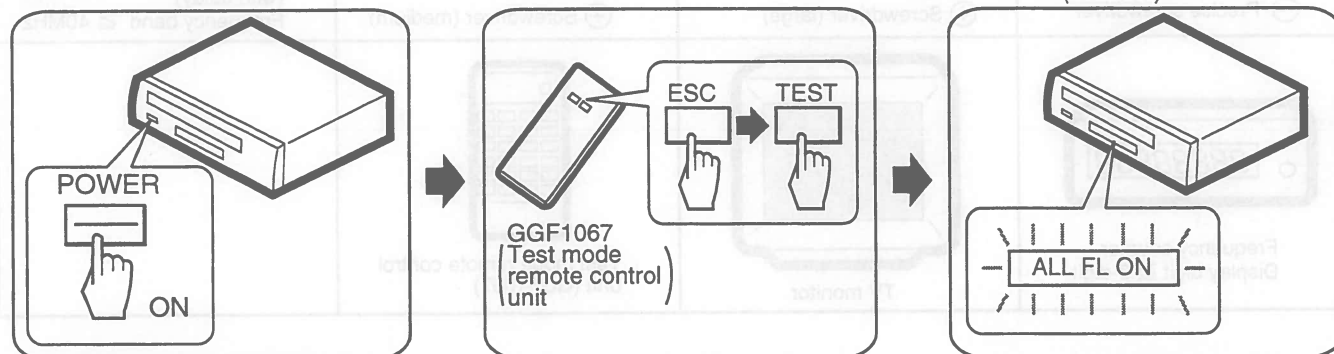

TEST MODE: DISC SET

• With TRAY (トレイ有りの場合)

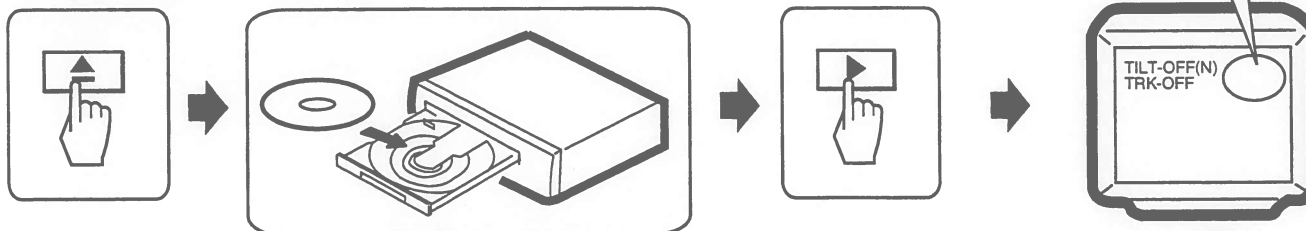

• No TRAY (トレイ無しの場合)

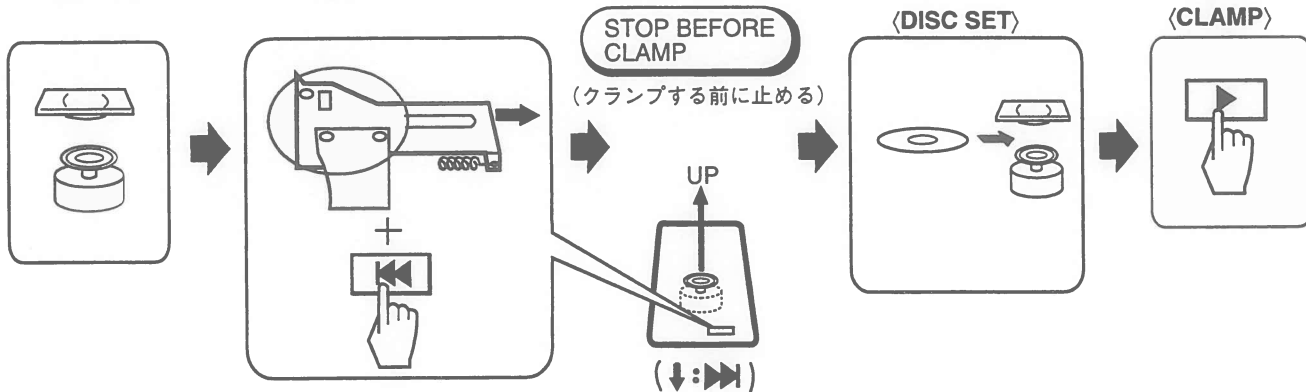

TEST MODE: PLAY

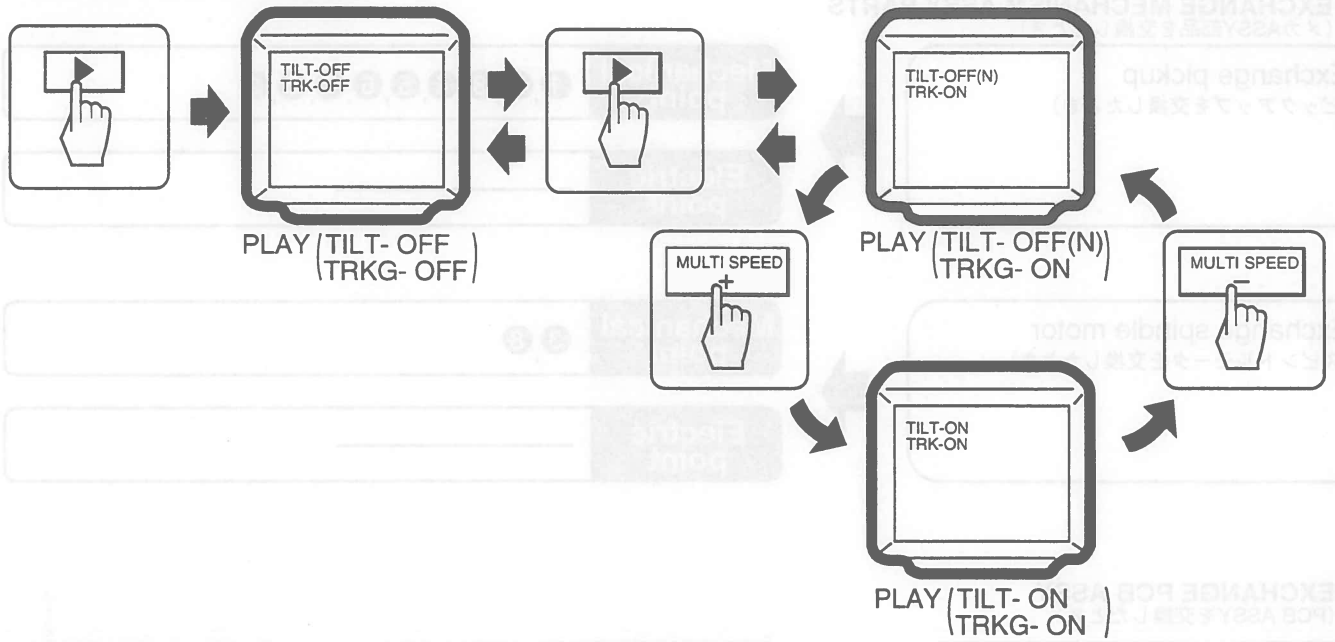

TEST MODE: OFF

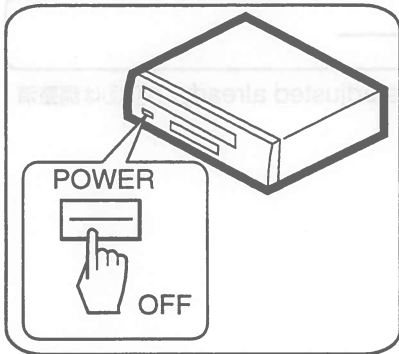

OR

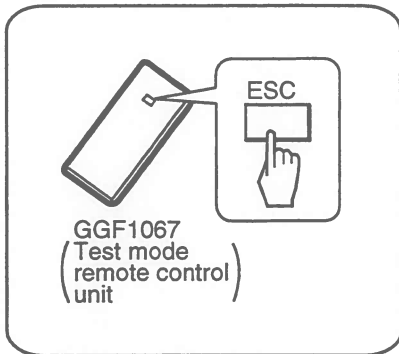

6.4 NECESSARY ADJUSTMENT POINTS (必要な調整項目)

When (このような時)

Adjustment Points

■ EXCHANGE MECHANISM ASSY PARTS
(メカASSY部品を交換したとき)

Exchange pickup
(ピックアップを交換したとき)

Mechanical point ①, ②, ③, ④, ⑤, ⑥, ⑦, ⑧, ⑨

Electric point _____

Exchange spindle motor
(スピンドルモータを交換したとき)

Mechanical point ③, ⑧

Electric point _____

■ EXCHANGE PCB ASSY
(PCB ASSYを交換したとき)

Exchange board
MOTHER ASSY
(マザーボードを交換したとき)

Mechanical point ①, ④, ⑤, ⑥, ⑨

Electric point _____

Note : ① and ② are adjusted already. (①,②は調整済)

6.5. MECHANICAL ADJUSTMENT (機構系の調整)

1 Tilt Offset Adjustment
(チルトオフセット調整)

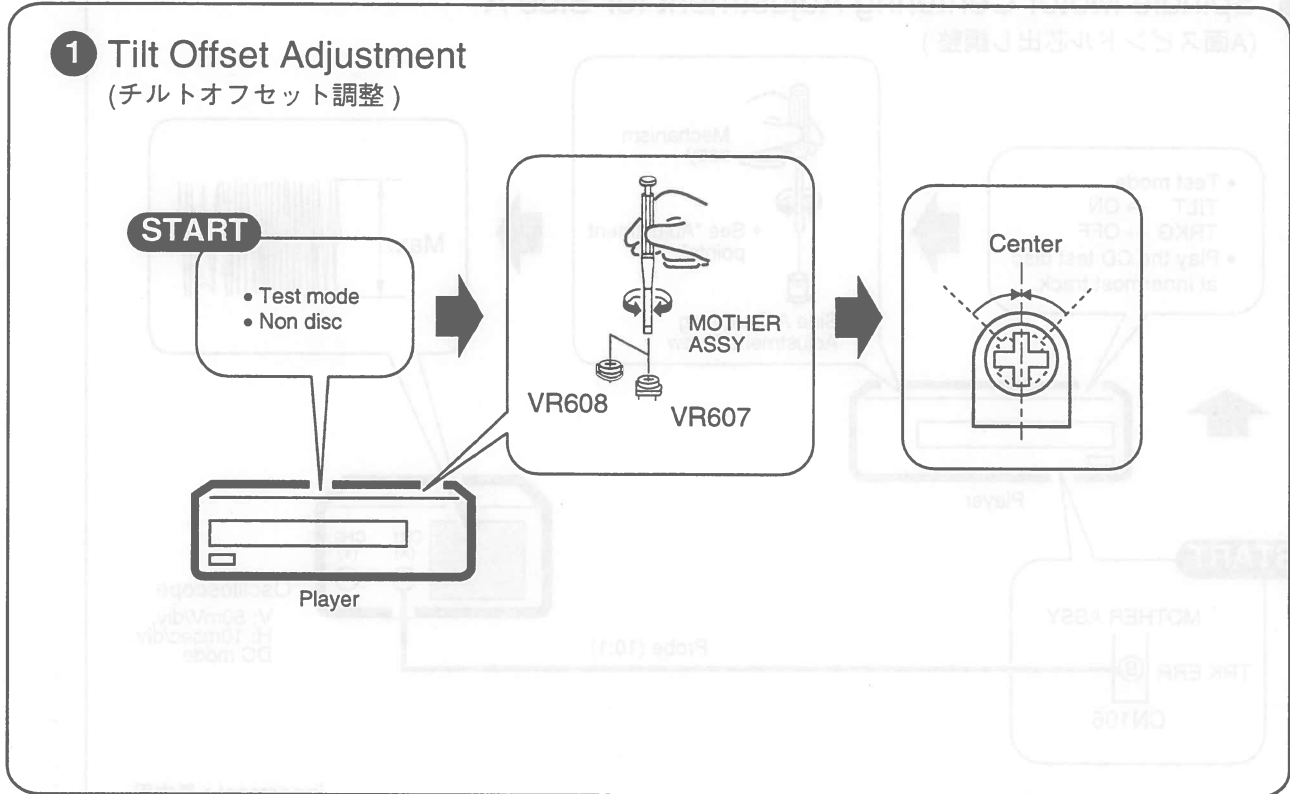

2 Tangential Direction Angle Adjustment for Side A
(A面タンジェンシャル傾き調整)

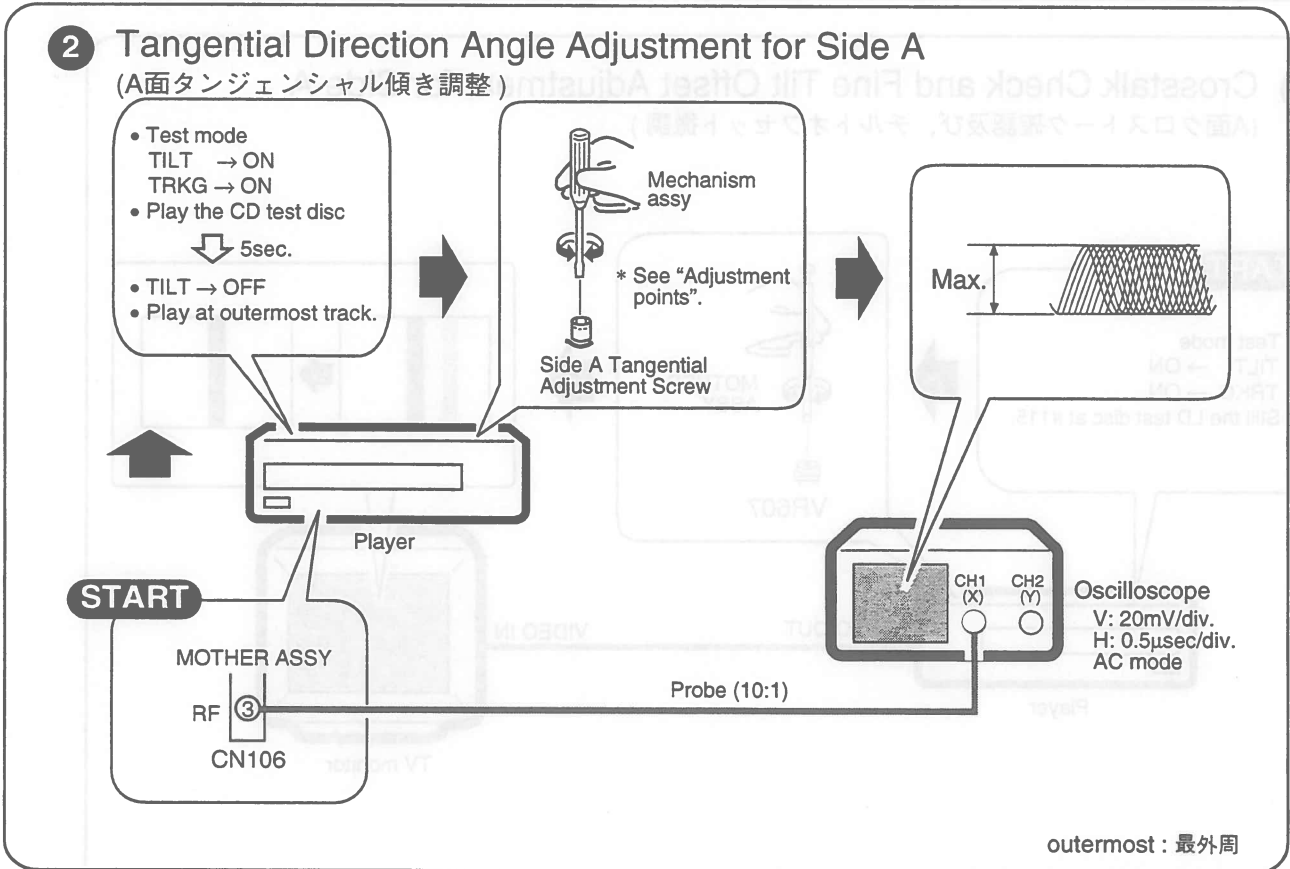

3 Spindle Motor Centering Adjustment for Side A

(A面スピンドル芯出し調整)

- Test mode
TILT → ON
TRKG → OFF
- Play the CD test disc at innermost track.

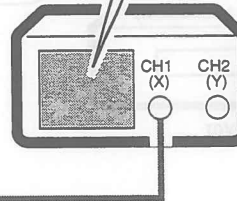
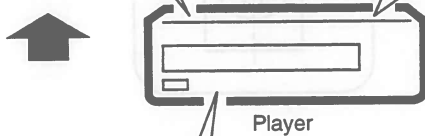
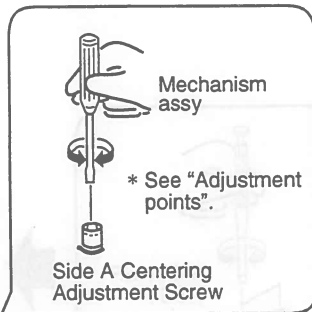

Oscilloscope
V: 50mV/div.
H: 10msec/div.
DC mode

START

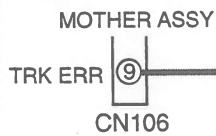

Probe (10:1)

innermost : 最内周

4 Crosstalk Check and Fine Tilt Offset Adjustment for Side A

(A面クロストーク確認及び、チルトオフセット微調)

START

- Test mode
TILT → ON
TRKG → ON
- Still the LD test disc at #115.

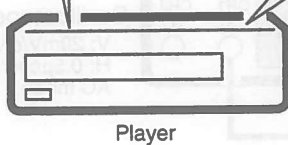
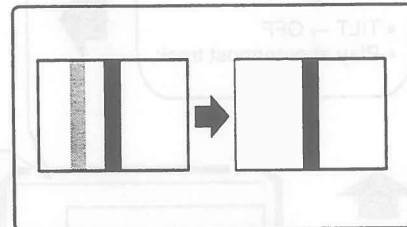

VIDEO IN

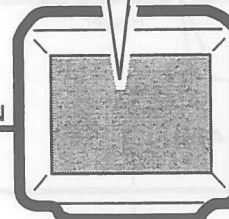

5 Focus Servo Loop Gain Adjustment (フォーカスサーボループゲイン調整)

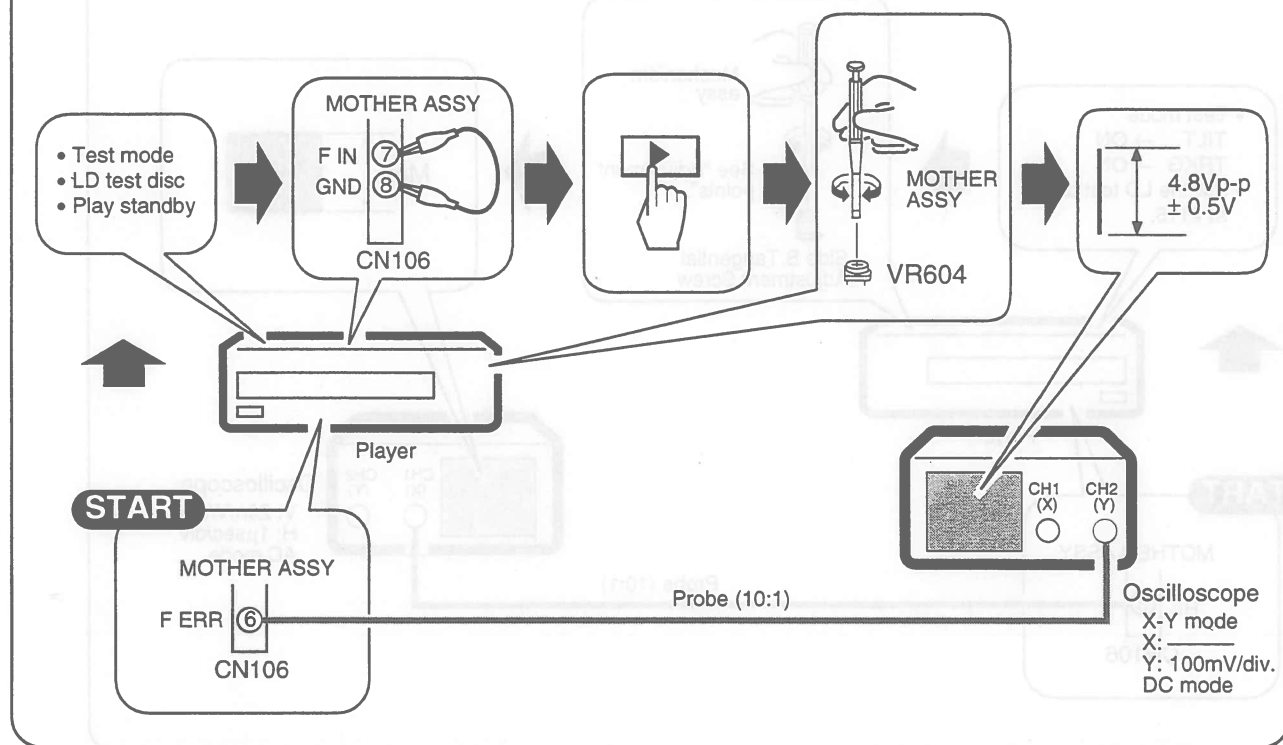

6 Tracking Servo Loop Gain Adjustment (トラッキングサーボループゲイン調整)

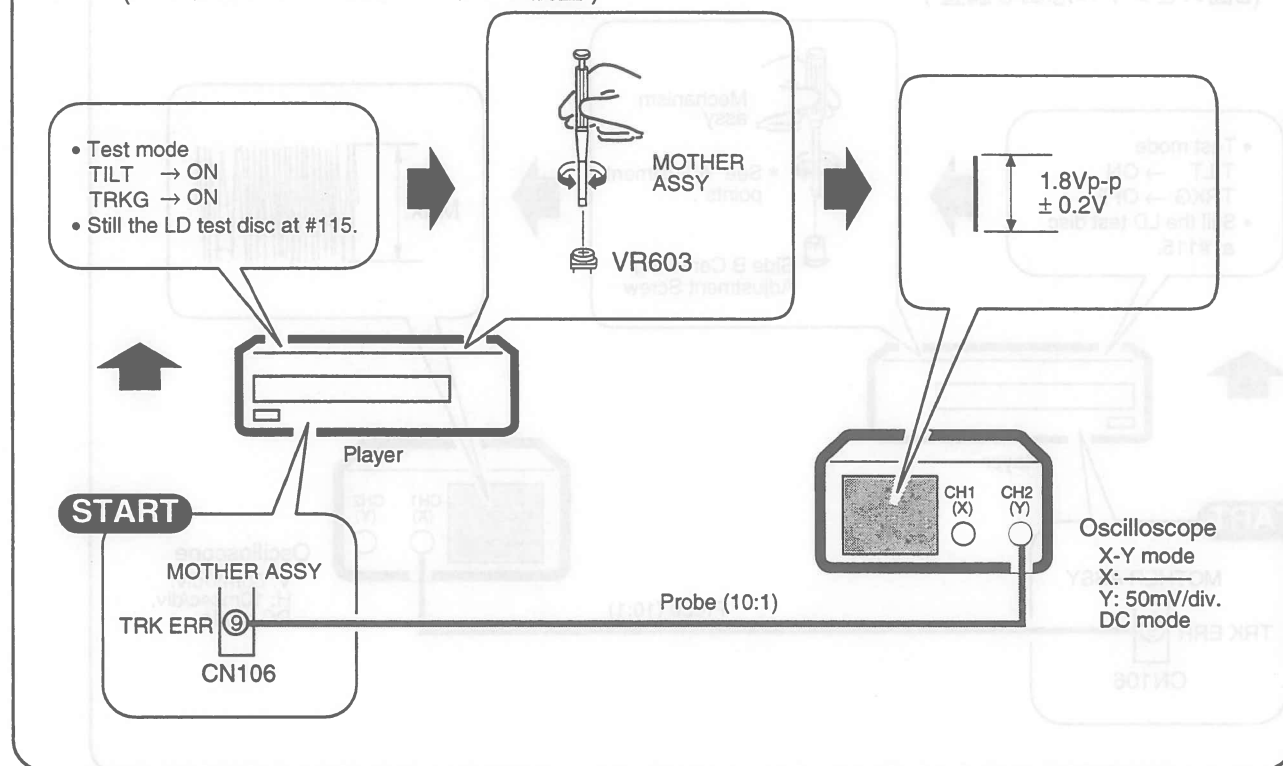

7 Tangential Direction Angle Adjustment for Side B
(B面タンジェンシャル傾き調整)

- Test mode
TILT → ON
TRKG → ON
- Still the LD test disc at #115.

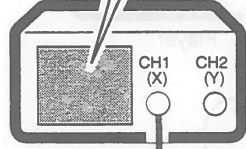
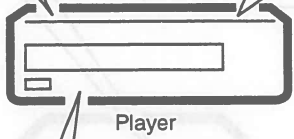
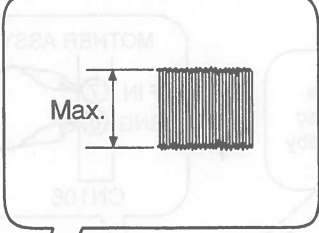
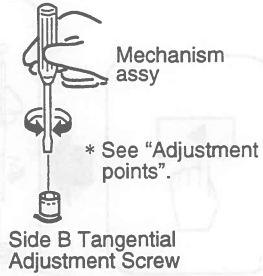

Oscilloscope
V: 20mV/div.
H: 1μsec/div.
AC mode

START

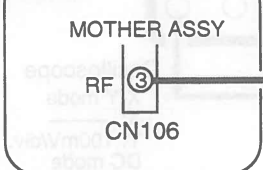

Probe (10:1)

8 Spindle Motor Centering Adjustment for Side B
(B面スピンドル芯出し調整)

- Test mode
TILT → ON
TRKG → OFF
- Still the LD test disc at #115.

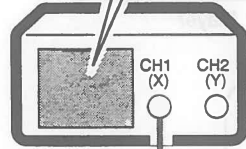
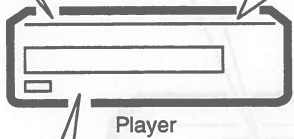
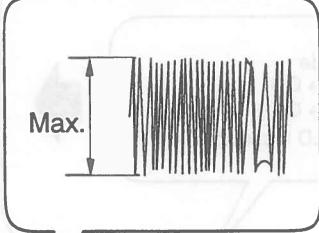
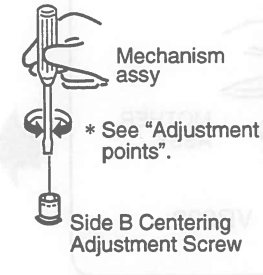

Oscilloscope
V: 50mV/div.
H: 10msec/div.
DC mode

START

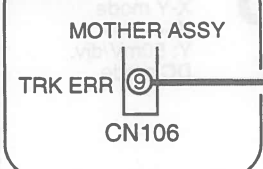

Probe (10:1)

9 Crosstalk Check and Fine Tilt Offset Adjustment for Side B
 (B面クロストーク確認及び、チルトオフセット微調)

START

- Test mode
TILT → ON
TRKG → ON
- Still the LD test disc at #115.

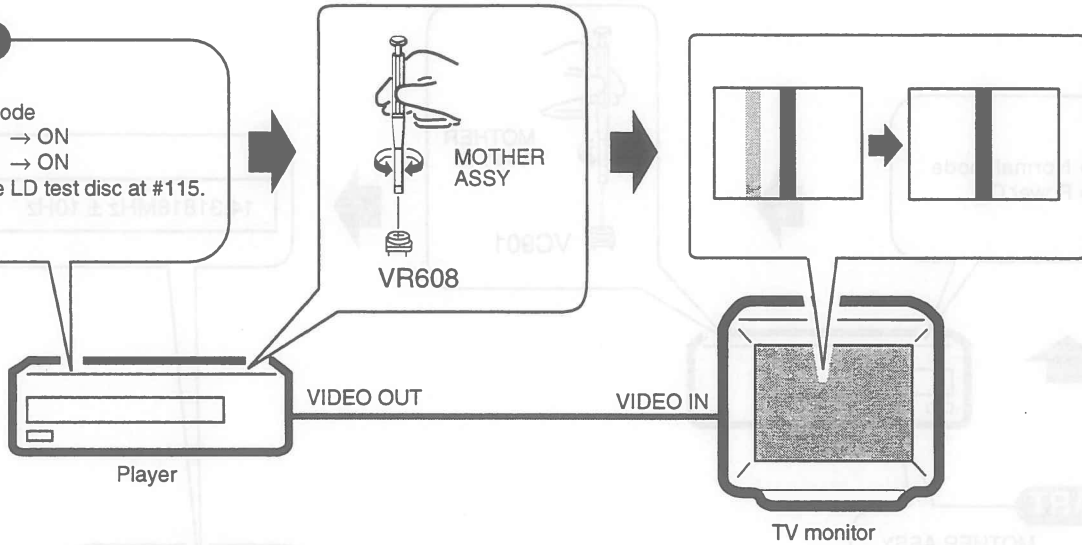

2 Output Video Level Adjustment
 (出力ビデオレベル調整)

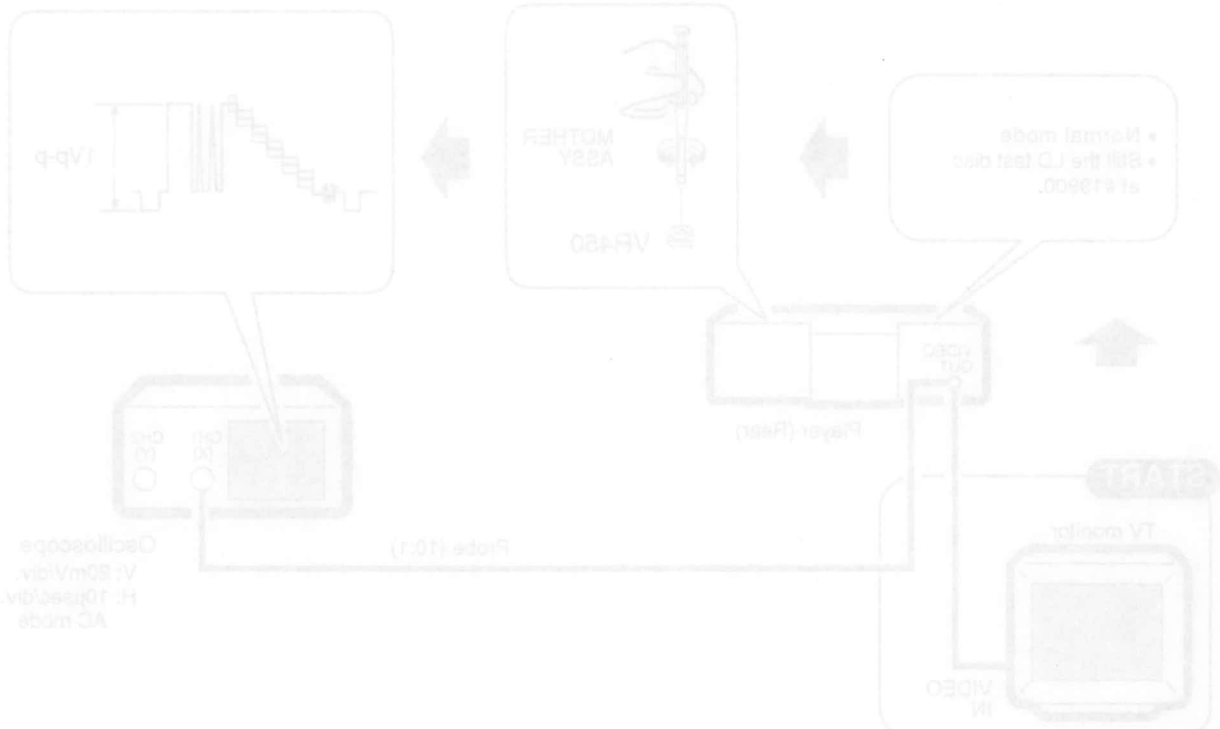

6.6 ELECTRICAL ADJUSTMENT (電気系の調整)

① Master Clock Adjustment (マスタークロック調整)

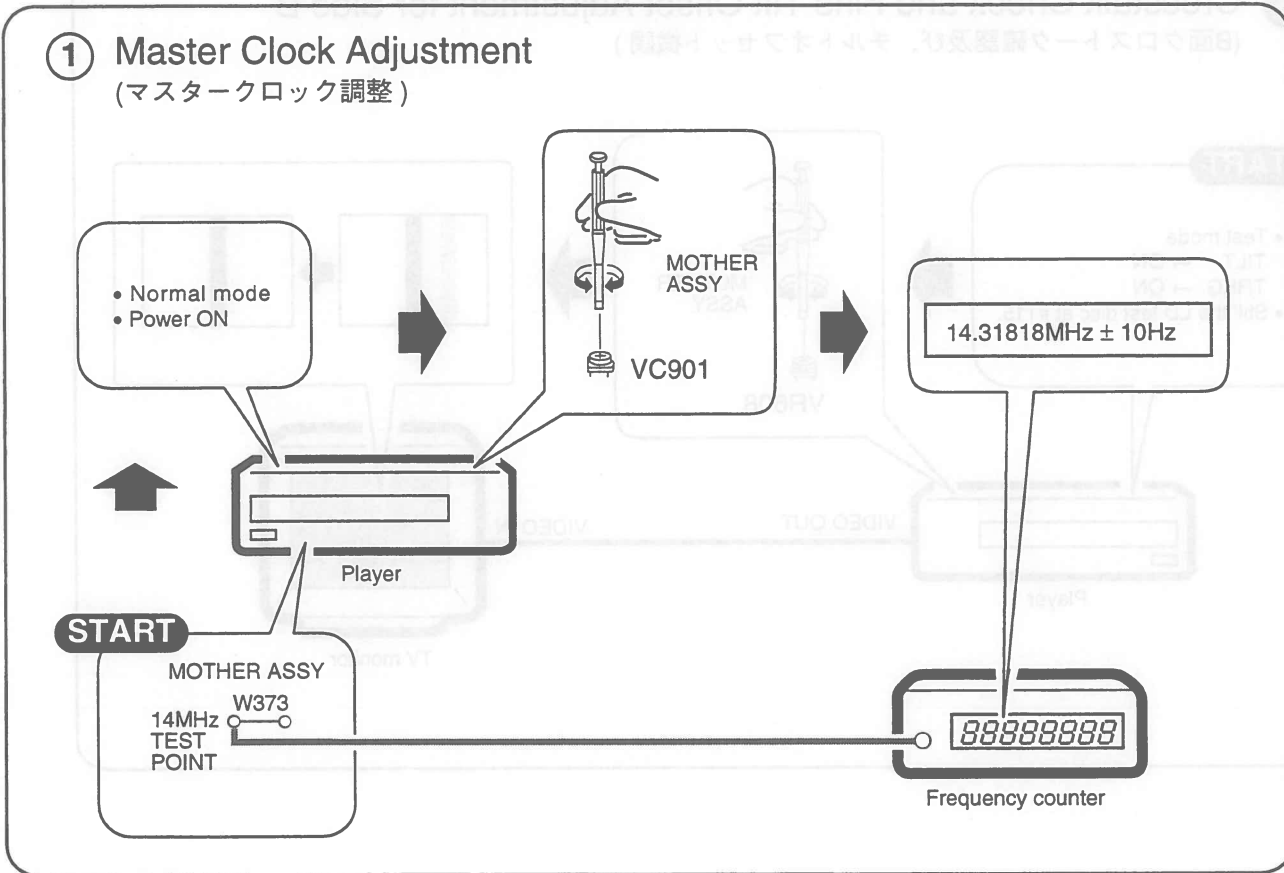

② Output Video Level Adjustment (出力ビデオレベル調整)

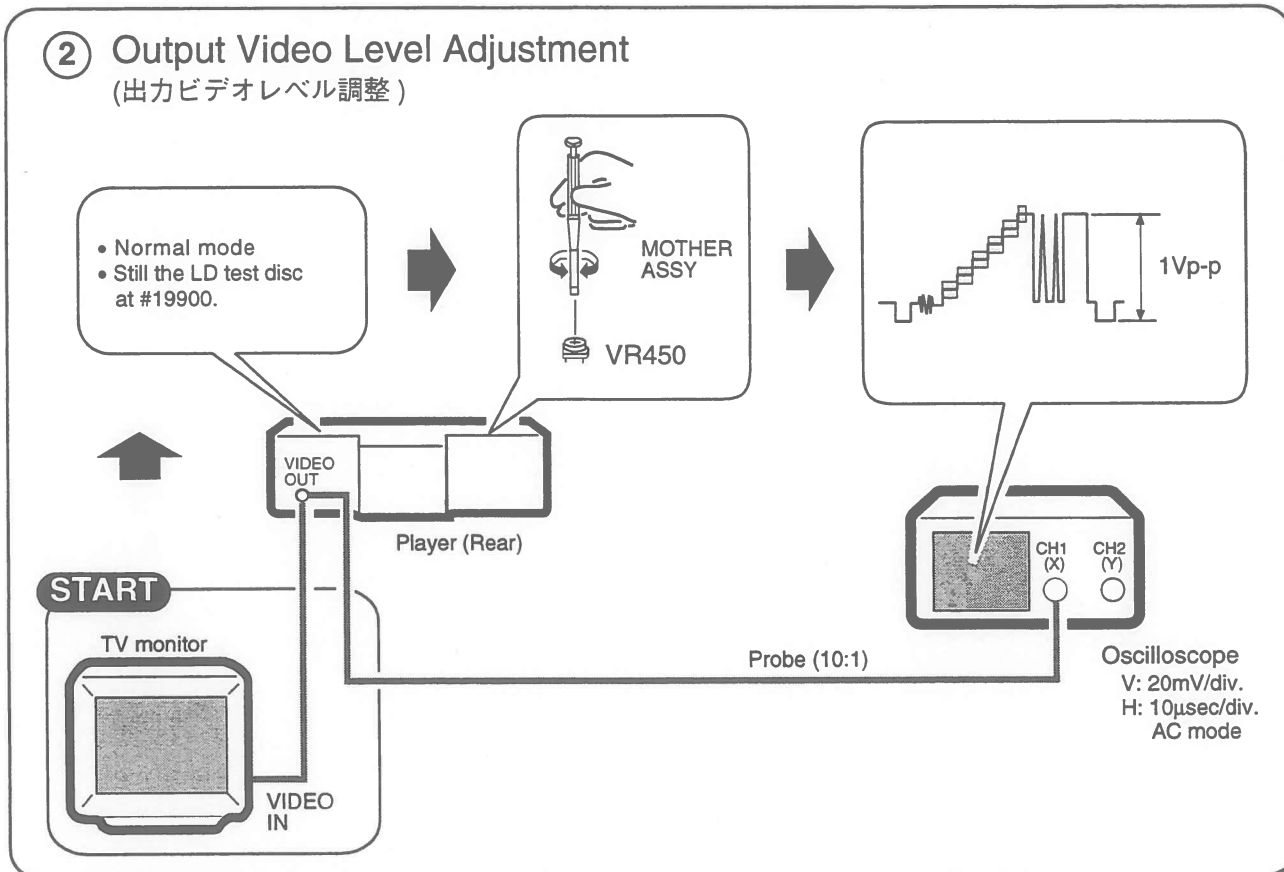

6.7 OPERATIONS IN THE TEST MODE (テストモード時のサービスリモコン操作方法)

■ Test Mode Remote Control Unit (GGF1067)

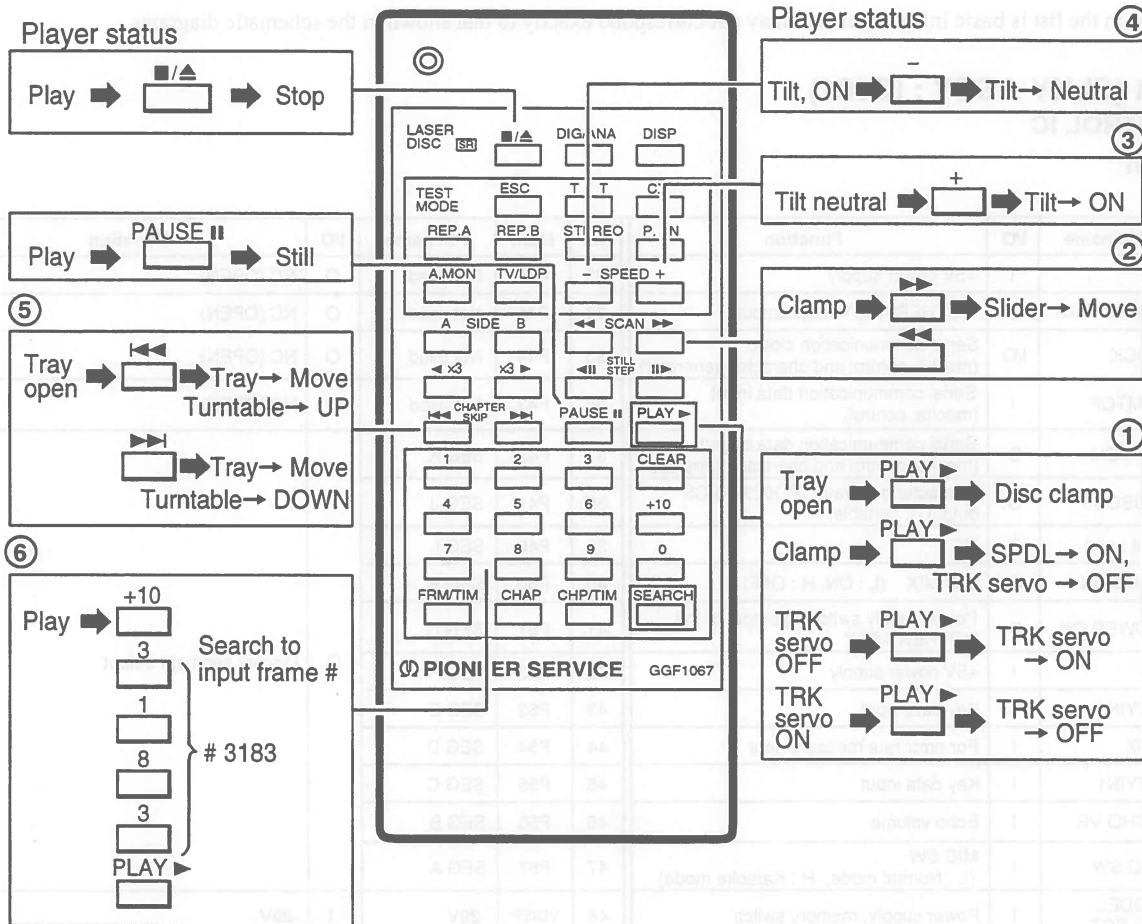

■ TV Monitor Display

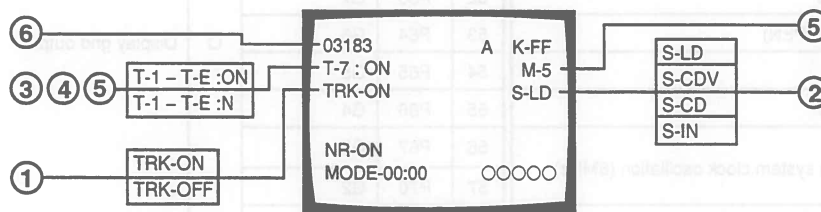

7. GENERAL INFORMATION

7.1 PARTS

7.1.1 IC

- The information in the list is basic information and may not correspond exactly to that shown in the schematic diagrams.

■ PD3360A (FLKY ASSY : IC101)

• MODE CONTROL IC

• Pin Function

No.	Mark	Pin name	I/O	Function	No.	Mark	Pin name	I/O	Function
1	VCC	—	I	+5V power supply	33	P46	Not used	O	NC (OPEN)
2	P90	XRESET OUT	O	MOTHER ASSY reset output	34	P45	Not used	O	NC (OPEN)
3	SCK1	XSCK	I/O	Serial communication clock (mecha. control and character generator)	35	P44	Not used	O	NC (OPEN)
4	SI1	S-MTOF	I	Serial communication data input (mecha. control)	36	P43	Not used	O	NC (OPEN)
5	SO1	S-FTOM	O	Serial communication data output (mecha. control and character generator)	37	P42	SEG K	O	Display segment output
6	P94	XOSDCS	O	Character generator (PD0234A) CS output (L : enable)	38	P41	SEG J		
7	P95	Not used	O	NC	39	P40	SEG I		
8	P96	XMIC ON	O	MIC MIX (L : ON, H : OFF)	40	P50	SEG H		
9	P97	POWER ON	O	Power supply switching output of the MOTHER ASSY	41	P51	SEG G		
10	AVCC	—	I	+5V power supply	42	P52	SEG F		
11	P00	KEYIN3	I	Key data input	43	P53	SEG E		
12	P01	FSX	I	For error rate measurement	44	P54	SEG D		
13	P02	KEYIN1	I	Key data input	45	P55	SEG C		
14	P03	ECHO VR	I	Echo volume	46	P56	SEG B		
15	P04	MIC SW	I	MIC SW (L : Normal mode, H : Karaoke mode)	47	P57	SEG A		
16	P05	MODEL SELECT	I	Power supply, memory switch	48	VDISP	-29V	I	-29V
17	P06	MODEL SELECT	I	CD tray, DVP switch	49	P60	G10	O	Display grid output
18	P07	MODEL SELECT	I	Main section key switch	50	P61	G9		
19	AVSS	—	I	GND	51	P62	G8		
20	TEST	Not used	I	GND	52	P63	G7		
21	X2	Not used	O	NC (OPEN)	53	P64	G6		
22	X1	Not used	I	+5V	54	P65	G5		
23	VSS	GND	I	GND	55	P66	G4		
24	OSC1	—	I	Main system clock oscillation (8MHz)	56	P67	G3		
25	OSC2	—	O		57	P70	G2		
26	XRST	XRESET IN	I		CPU reset (L : RESET)	58	P71		
27	IRQ0	SHAKE	I/O	Mechanism control serial communication requirement	59	P72	LED (DISOFF) (FINE WIDE, PICTURE CONT)	O	LED output : Display OFF or picture control (Fine wide) indication
28	IRQ1	SEL IR	I	Remote control input	60	P73	LED (QCKTRN)	O	LED output : Quick turn indication
29	P14	Not used	O	NC (OPEN)	61	P74	LED (STANDBY)	O	LED output : Standby
30	P15	EFLG	I	For error rate measurement	62	P75	Not used	O	NC (OPEN)
31	P16	Not used	I	GND	63	P76	Not used	O	NC (OPEN)
32	P47	DOGFOOD	O	Pulse output for WATCH DOG	64	P77	Not used	I	NC (OPEN)

■ PD0245A2 (MOTHER ASSY : IC101)

● MECHANISM CONTROL IC

● Pin Arrangement (Top View)

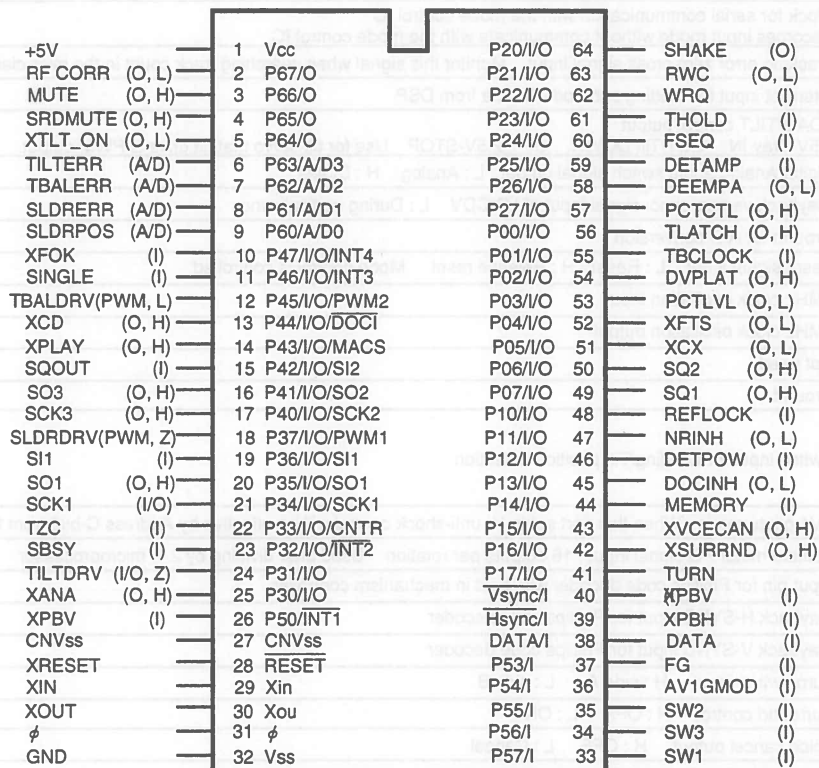

● Pin Function

No.	Pin Name	I/O	Function
1	VCC	I	Power supply pin Apply 5V±10%
2	RFCORR	O	RF correction switch signal output H : Gain UP CD, CDV-A : Low, CAV inner circuit gain up, others are High
3	MUTE	O	Audio mute control signal output of audio system L : Release MUTE H : MUTE
4	SRDMUTE	O	Mute control signal output for AC3 Release MUTE during playback. L : Release MUTE H : MUTE
5	XTILT ON	O	Tilt operation information L : During operation In the OPEN/CLOSE, the voltage will up about 10% by using this port.
6	TILTERR	I A/D	This signal is A/D converted as the tilt servo control input. Control the tilt motor so that this signal becomes 2.5V.
7	TBALERR	I A/D	Tracking balance error signal input This signal is A/D converted as the tracking offset control input.
8	SLDERR	I A/D	This signal is A/D converted as the slider servo control input. Control the tilt motor so that this signal becomes 2.5V.
9	SLDPOS	I A/D	Pickup position detection switch input Detect the position by reading A/D input value which each switches are resistance divided.
10	XFOK	I	Focus servo lock signal input L : Lock H : Unlock Use for lock detection of focus servo.
11	SINGLE	I	This information transmit to mode control by communication. L : Port high H : Port low Use for the signal mode
12	TBALDRV	O PWM	Output the tracking offset signal to PWM output, then use for auto tracking offset. 910 μsec period, tri-state control H, L, Z
13	XCD	O	LD/CD switch signal output L : CD H : LD
14	XPLAY	O	Signal output during spindle servo L : During servo H : During acceleration, brake and stop
15	SQOUT	I	Command data input from DSP Read out SUBQ
16	SO3	O	Serial 3 data signals output Serial signals are common used and signal distinguishes from the latch signals (DVPLAT and TLAT).
17	SCK3	O	Serial 3 clock signals output
18	SLDRDRV	O PWM	Slider control signal output 5V=FWD, 0V=REV, 2.5V=STOP 910 μsec period, tri-state control H, L, Z

No.	Pin Name	I/O	Function
19	SI1	I	Data input from the mode control IC
20	SO1	O	Serial data output to the mode control IC
21	SCK1	I/O	Clock for serial communication with the mode control IC Becomes input mode without communicate with the mode control IC
22	TZC	I INT	Tracking error zero cross signal input Monitor this signal when searching track count in the miss clamp detection.
23	SBSY	I	Interrupt input for reading sub-code Q data from DSP
24	TILTDRV	I/O	LOAD/TILT control output 0.5V-Tray IN, OUT/Tilt DOWN, UP 2.5V-STOP Use for tilt servo that tilt drive is PWM output.
25	XANA	O	Digital/Analog audio switch signal output L : Analog H : Digital
26	XPBV	I	Playback vertical sync. signal input of LD/CDV L : During vertical sync.
27	CNVss	I	Ground for A/D conversion
28	XRESET	I	Reset signal input L : Reset H : Release reset Mode control is controlled.
29	XIN	I	9MHz clock oscillation input
30	XOUT	O	9MHz clock oscillation output
31	N.C.	O	Not used
32	GND	I	Ground
33	SW1	I	Switch input for Loading/Tilt position detection
34	SW3		
35	SW2		
36	AV1GMOD	I	AV1 gijutu mode When this port set to H, anti-shock control will be effective by Address C-bit2 from the mode control.
37	FG	I	Spindle motor FG signal input 16 outputs per rotation Used after dividing by 2 in microprocessor
38	DATA	I	Input pin for Phillips code decoder with built in mechanism controller
39	XPBH	I	Playback H-SYNC input for Phillips code decoder
40	XPBV	I	Playback V-SYNC input for Phillips code decoder
41	TURNA	I	Turn switch input H : side A L : side B
42	XSURRND	O	Surround control H : OFF L : ON
43	XVCECAN	O	Voice cancel output H : OFF L : Cancel
44	MEMORY	I	Memory model discrimination H : Memory model L : Non-memory model
45	DOCINH	O	Control the clamp pulse and clamp killer by tri-state value
46	DETPOW	I	Use for power abnormal signal input port. L : Normal H : Abnormal
47	NRINH	O	Control output of the noise reduction switch signal output L : CX ON H : CX OFF
48	REFLOCK	I	Reference signal input from DVP L : Phase not aligned H : Phase aligned (Non-memory)
49	SQ1	O	Analog audio switch signal output 1/L L : Squelch OFF H : Squelch ON
50	SQ2	O	Analog audio switch signal output 2/R L : Squelch OFF H : Squelch ON
51	XCX	O	Analog audio CX noise reduction switch signal output L : CX ON H : CX OFF
52	XFTS	O	Serial command output switch signal output of DSP/others L : DSP H : others
53	PCTLVL	O	Signal output for the picture quality adjustment L : SHARP2 (strong) H : SHARP1 (weak)
54	DVPLAT	O	PD0234 serial latch signal output Latches at falling edge.
55	TBCLOCK	I	Spindle lock signal input L : Unlock H : Lock
56	TLATCH	O	DAC & digital filter PD2026B serial control latch signal output Latches at falling edge.
57	PCTCTL	O	Outline correction signal output L : Correction OFF H : Correction ON
58	DEEMPA	O	DSP deemphasis control L : OFF H : ON
59	DETAMP	I	Spindle over-current detection signal input L : Over current H : Normal
60	FSEQ	I	Subcode sync. conformity detection signal input L : Not conformity H : Conformity
61	THOLD	I	Track jump accelerating / decelerating signal input L : other H : accelerating / decelerating
62	WRQ	I	Subcode Q reading OK signal input L : NG H : OK This pin will be H when Subcode Q data passed by CRC check.
63	RWC	O	DSP read / write command signal output L : Read H : Write
64	SHAKE	I/O	Handshake signal for data communication with the mode control IC This pin is the bilateral data line and each microprocessor control the Input / Output.

■ LA7134M (MOTHER ASSY : IC400)

• VIDEO IC

• Block Diagram

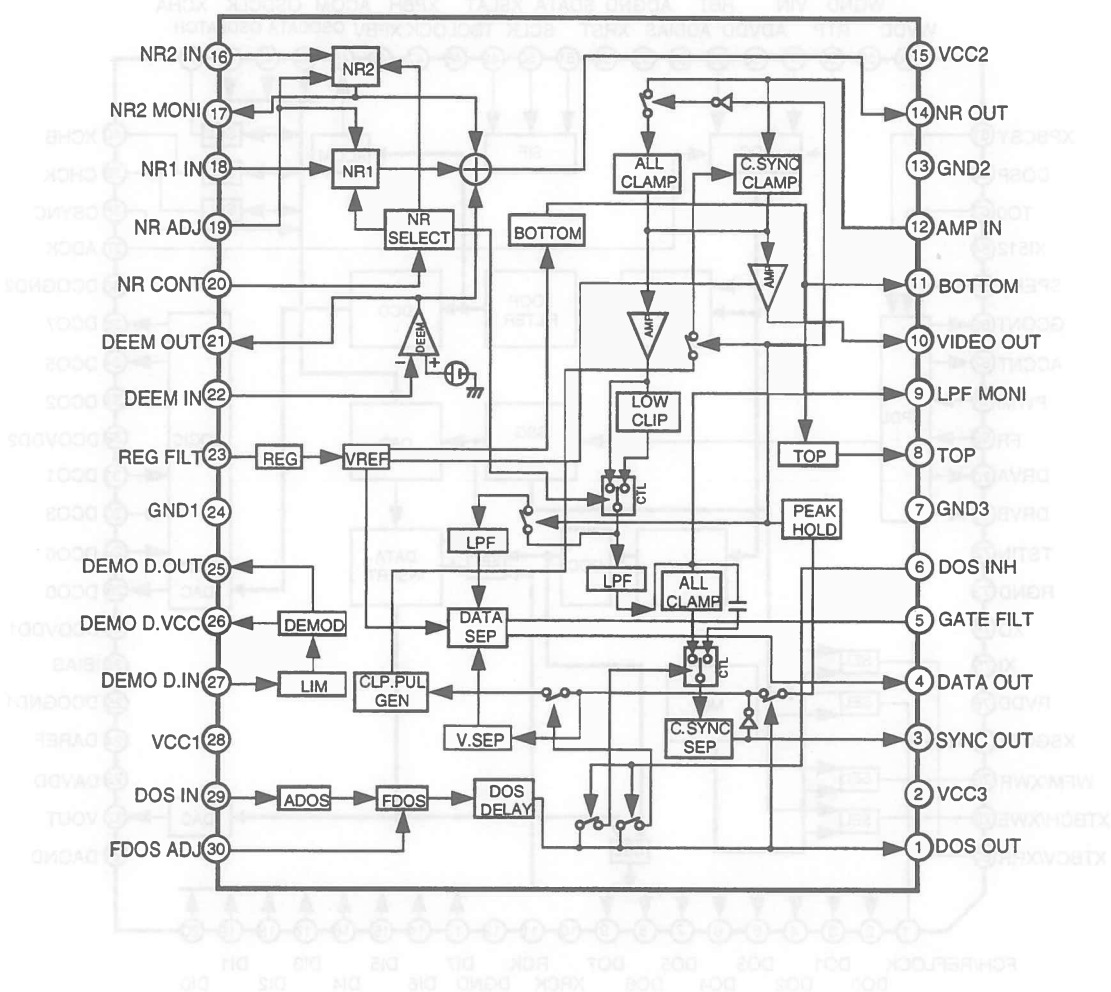

■ PD0234A (MOTHER ASSY : IC500)
 • DIGITAL VIDEO PROCESSOR

• Block Diagram

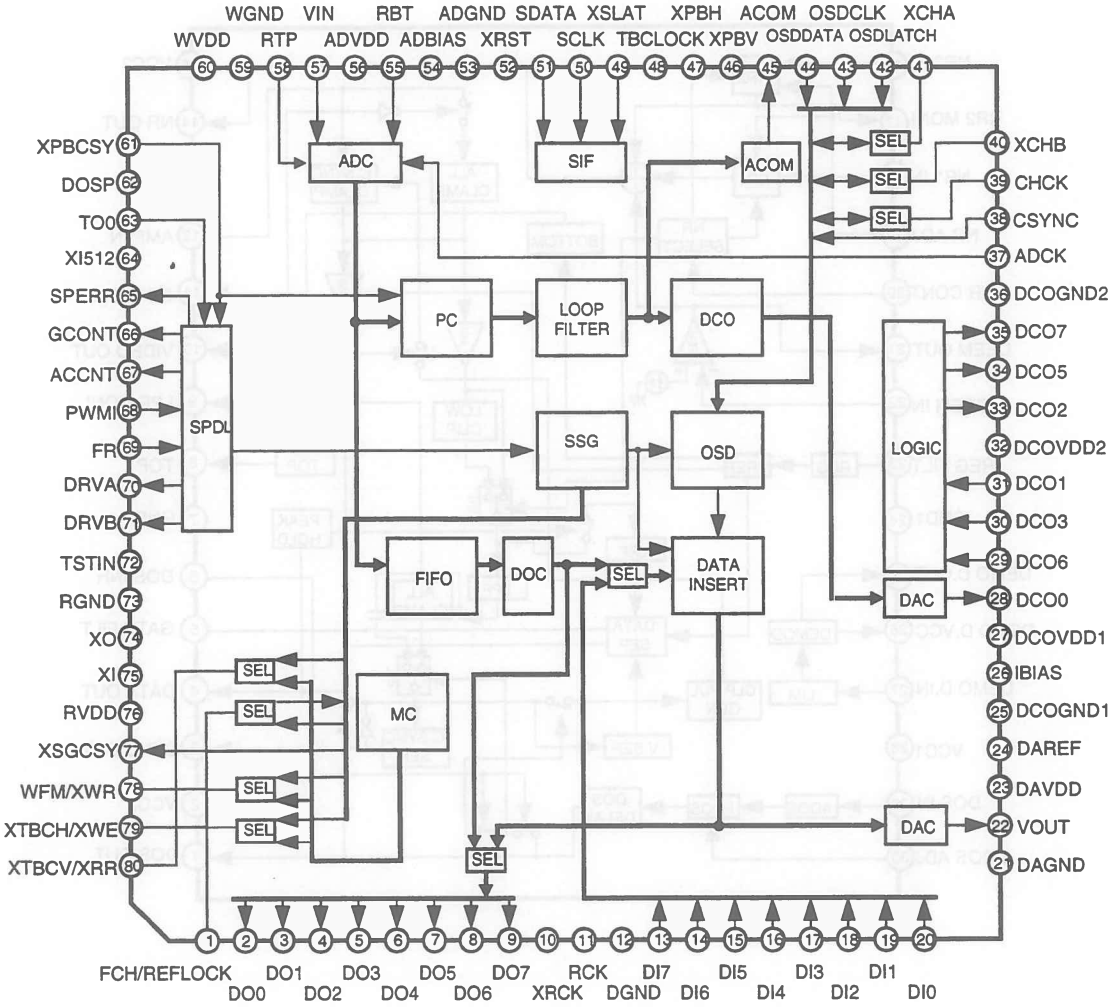

• Pin Function

No.	Pin Name	I/O	Function	
1	FCH	I	MEMSYS:1	Switch the field of SSG by "H"
	REFLOCK	O	MEMSYS:0	Outputs "H" when the phase difference of H/V sync. signal associated with the time-base-corrected video signal and those associated with SSG is small enough.
2	DO0	O		Outputs the digital data of the time-base-corrected video signal for the memory system. When using the internal memory controller (MEMSYS:1 & EXTMC:0), output for field memory and external output are common used. Perform the data output setting with the serial command. DO7 : MSB , DO0 : LSB
3	DO1			
4	DO2			
5	DO3			
6	DO4			
7	DO5			
8	DO6			
9	DO7			
10	XRCK	O		Inverting outputs the CLK of the reading system. When using the internal memory controller (MEMSYS:1 & EXTMC:0), phase is able to control with the serial command.
11	RCK	O		Outputs the CLK of the reading system. When using the internal memory controller (MEMSYS:1 & EXTMC:0), phase is able to control with the serial command.
12	DGND	—		Ground of digital system Connect to GND.
13	DI7	I		Digital video signal input Outputs the field memory when using the internal memory controller (MEMSYS:1 & EXTMC:0) and inputs the external signal when using the external A/D. DI7 : MSB , DI0 : LSB
14	DI6			
15	DI5			
16	DI4			
17	DI3			
18	DI2			
19	DI1			
20	DI0			
21	DAGND	—		Ground for DAC Connect to GND.
22	VOUT	O		DAC output of the time-base-corrected video signal
23	DAVDD	—		Power supply for DAC Connect to GND.
24	DAREF	—		Reference pin for DAC Normally, decoupling to the DAGND through the 0.1 μ F laminated ceramic capacitor.
25	DCOGND1	—		Ground for DCO Connect to GND.
26	IBIAS	—		Current setting pin of the bias circuit Normally, connect to DAGND through the 10k Ω resistor.
27	DCOVDD1	—		Power supply for DCO Connect to +5V.
28	DCO0	O		DCO output pin Outputs a fsc in synchronization with the input video signal. This signal is multiplied by 4 to produce CLK of writing system.
29	DCO6	I		Waveform shaping input pin 6 Inputs a signal obtained by delaying the DCO5 output signal by 35 ns. (to be self biased)
30	DCO3	I		Waveform shaping input pin 3 Inputs a signal obtained by delaying the DCO5 output signal by 70 ns. (to be self biased)
31	DCO1	I		Waveform shaping input pin 1 Inputs a DCO0 output signal via the fsc BPF. (to be self biased)
32	DCOVDD2	—		Power supply for output multiplied by 4 Connect to +5V.
33	DCO2	O		Waveform shaping input pin 2 Outputs a signal obtained through waveform shaping of the DCO0 output signal.
34	DCO5	O		Waveform shaping input pin 5 Outputs a signal multiplied by 2.
35	DCO7	O		Waveform shaping input pin 7 Outputs a signal multiplied by 4.
36	DCOGND2	—		Ground for output multiplied by 4 Connect to GND.
37	ADCK	I		CLK input for writing system Inputs DCO7 output signal via a 4fsc BPF. (to be self biased)
38	CSYNC	I		Composite sync. input for character generator When using the OSD for single (EXTMIX:1), input the composite sync. for generating the character.
39	CHCK	I	EXTMIX :1	CLK input for character generator Inputs 2fsc.
	CHCK	O	EXTMIX :0	CLK output for character generator Outputs 2fsc.
40	XCHB	O	EXTMIX :1	Blanking signal output
	XCHB	I	EXTMIX :0	Blanking signal input Inputs "L" when inserting the blanking signal.
41	XCHA	O	EXTMIX :1	Character signal output
	XCHA	I	EXTMIX :0	Character signal input Inputs "L" when inserting the character signal.
42	OSDLATCH	I		Latch input for OSD Serial transmission of the OSD control data is able to accept by this pin set to "L".
43	OSDCLK	I		CLK input for reading the OSD data

No.	Pin Name	I/O	Function
44	OSDDATA	I	Control data input for OSD Read the data in synchronization with CLK which input to OSDCLK pin.
45	ACOM	O	Jitter correction signal output for analog audio Use for cancelling the jitter element of analog audio.
46	XPBV	O	PB system V sync. output Outputs the signal obtained by separating V sync. signal from the signal at pin 61 (XPBCSY) with negative logic.
47	XPBH	O	PB system H sync. output Outputs the signal obtained by separating H sync. signal from the signal at pin 61 (XPBCSY) with negative logic.
48	TBCLOCK	O	PLL lock detection signal output Outputs "H" when the spindle loop and the TBC loop are locked.
49	XSLAT	I	Serial interface latch input Gives the latch timing for data applied to the serial interface. Latches at "L".
50	SCLK	I	CLK input for the serial interface SDATA value will be read at the rising edge.
51	SDATA	I	Data input pin for the serial interface
52	XRST	I	System reset input Input for initializing the internal register of IC with negative logic.
53	ADGND	—	Ground for ADC Connect to GND.
54	ADBIAS	—	NC or connect to ADGND.
55	RBT	I	ADC bottom reference input Gives the bottom reference voltage of ADC.
56	ADVDD	—	Power supply for ADC Connect to +5V.
57	VIN	I	ADC input Inputs the composite video signal.
58	RTP	I	ADC top reference input Gives the top reference voltage of ADC.
59	WGND	—	Ground for writing system Connect to GND.
60	WVDD	—	Power supply for writing system Connect to +5V.
61	XPBCSY	I	Inputs the composite sync. signal of PB system with negative logic.
62	DOSP	I	Inputs the dropout detection pulse with positive logic.
63	TOO	I	Inputs the tracking-servo open signal with positive logic.
64	XI512	O	Outputs a 1/512th division of the CLK of reading system.
65	SPERR	O	PFD error output of the spindle error It outputs the result of comparison (PFD) between PBH and reading system H in tristate.
66	GCONT	O	Spindle gain control output Outputs a PWM signal according to the serial-command specified value.
67	ACCNT	O	Acceleration control output Tristate output of the acceleration/deceleration signal, which depends either on the forced acceleration/deceleration signal, the error detection by serial command or error detection by H sync. signal.
68	PWMI	I	Spindle error PWM input Inputs a signal obtained through the voltage comparison between the spindle error signal which has passed through a loop filter and the chopping wave.
69	FR	I	Spindle error direction element input Inputs a signal obtained through the voltage comparison between the spindle error which has passed through a loop filter and the destination voltage.
70	DRVA	O	Output for driving the spindle motor driver
71	DRVB		It is applicable to either a brush or brushless motor, selection of which is by a serial command.
72	TSTIN	I	Input for IC test Fixed to "L".
73	RGND	—	Ground for reference system Connect to GND.
74	XO	O	Connect the X'tal. Connect the 8fsc when using the internal memory controller (MEMSYS:1 & EXTMC:0) and the 4fsc is at others.
75	XI	I	
76	RVDD	—	Power supply for reference system Connect to +5V.
77	XSGCSY	O	Internal SSG composite sync. output Outputs the composite sync. signal of the internal SSG with negative logic. It can be delayed by a serial command with a specified delay duration.
78	WFM	O	MEMSYS:1 & EXTMC:1 Field monitor output of write system Outputs "H" for the odd field.
	XWR	O	MEMSYS:1 & EXTMC:0 Write reset output Outputs a signal to initializing the writing address of field memory. Outputs "L" pulse for 1CLK on every field of write system. Connect to XWRST input of field memory.
79	XTBCH	O	MEMSYS:1 & EXTMC:1 TBC H sync. output Outputs the time-base-corrected H sync. signal with negative logic.
	XWE	O	MEMSYS:1 & EXTMC:0 Write enable output Control the writing operation of field memory. "L" for enable and "H" for disenable. Connect to XWE input of field memory.
80	XTBCV	O	MEMSYS:1 & EXTMC:1 TBC V sync output Outputs the time-base-correcter V sync. signal with negative logic.
	XRR	O	MEMSYS:1 & EXTMC:0 Read reset output Outputs a signal to initializing the reading address of field memory. Outputs "L" pulse for 1CLK on every each field of read system. Connect to XRRST input of field memory.

LC78620E (MOTHER ASSY : IC802)
• SERVO CONTROLLER & EFM DEMODULATOR

• Block Diagram

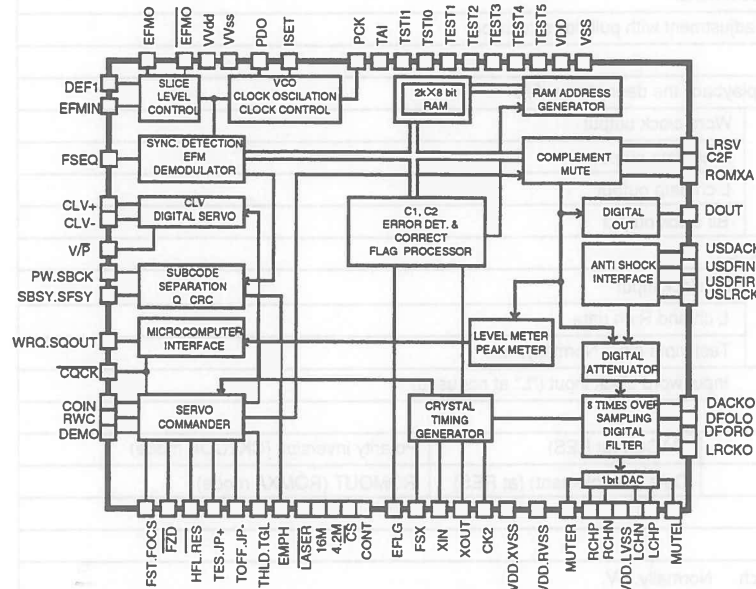

• Pin Arrangement (Top View)

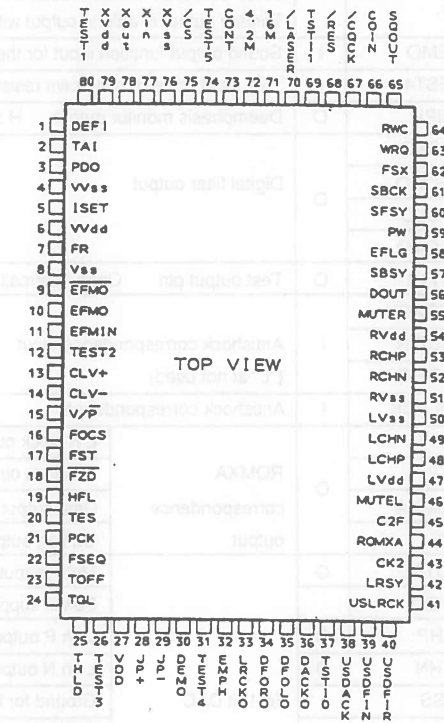

• Pin Function

No.	Pin Name	I/O	Function	
1	DE-FI	I	Defect detection signal (DEF) input pin ("L" at not used)	
2	TAI	I	For PLL Test input pin with pull-down resistor	
3	PDO	O		Phase comparison output for controlling the external VCO
4	V Vss	—		Power supply for PLL and internal VCO Normally, 0V.
5	ISET	AI		Connect a resistor for current adjustment of PDO output
6	V VDD	—		Ground for internal VOO Normally, 5V.
7	FR	AI		For VCO frequency range adjustment
8	Vss	—		Ground for digital system Normally, 0V.
9	EFMO	O	For slice level control EFM signal inversion output	
10	EFMO	O		EFM signal output
11	EFMIN	I		EFM signal input
12	TEST2	I	Test input pin with pull-down resistor	
13	CLV+	O	Output pin for controlling the spindle servo Acceleration for CLV+ is "H" and Deceleration for CLV- is "H".	
14	CLV-	O	Tristate output is able to output with command	
15	V/P	O	Automatic switching monitor output of rough servo/phase control H : Rough servo , L : Phase control mode	
16	FOCS	O	Output pin for focus servo ON/OFF Focus servo ON for "L"	
17	FST	O	Focus start pulse output (open drain output)	
18	F2D	I	Focus error zerocross signal input ("L" at not used)	
19	HFL	I	Track detection signal input (schmitt input)	
20	TES	I	Tracking error signal input (schmitt input)	
21	PCK	O	Clock monitor output for EFM data playback (4.3218MHz at phase clock)	
22	FSEQ	O	Sync. signal detection output Becomes "H" when the sync. signals between the detected sync. signal from EFM signal and internal generated sync. signal are aligned.	
23	TOFF	O	Tracking OFF output	
24	TGL	O	Output pin for output tracking gain switch Gain up for "L".	
25	THLD	O	Tracking hold output	
26	TEST3	I	Test input pin with pull-down resistor	

No.	Pin Name	I/O	Function
27	VDD		Power supply for digital system Normally, 5V.
28	JP+	O	Output pin for track jump When JP+ is "H" , Acceleration in the outer direction jump or Deceleration in the inner direction jump.
29	JP-		When JP- is "H" : Acceleration in the inner direction jump or deceleration in the outer direction jump. Tristate output is able to output with the bcommand.
30	DEMO	I	Sound output function input for the player adjustment with pull-down resistor
31	TEST4	I	Test input pin with pull-down resistor
32	EMPH	O	Deemphasis monitor output H : during playback the deemphasis disc
33	LRCKO	O	Word clock output
34	DFORO		R ch data output
35	DFOLO		L ch data output
36	DACKO		Bit clock output
37	TST10	O	Test output pin Open (Normally, output "L")
38	USDACK	I	Bit clock input
39	USDFIN		L ch and R ch data
40	USDFIR		Test input pin Normally, "L".
41	USLRCK	I	Antishock correspondence Input word clock input ("L" at not used)
42	LRSY	O	L/R clock output
43	CK2		Bit clock output DACLK (at RES) Polarity inversion (CK2COK mode)
44	ROMXA		Data output Data (complement) (at RES) ROMOUT (ROMXA mode)
45	C2F		C2 flag output
46	MUTEL		Mute output
47	L VDD	O	Power supply for L ch Normally, 5V.
48	LCHP		L ch P output
49	LCHN		L ch N output
50	LVSS		Ground for L ch Normally, 0V.
51	RVSS		Ground for R ch Normally, 0V.
52	RCHN		R ch N output
53	RCHP		R ch P output
54	RVDD		Power supply for R ch Normally, 5V.
55	MUTER		Mute output
56	DOUT		O
57	SBSY	O	Perion signal output of subcode block
58	EFLG	O	Correction monitor output of C1, C2, single and double
59	PW	O	Subcode P, Q, R, S, T, U and W output
60	SFSY	O	Period signal output of subcode frame Rise down when the subcode is strndbyed.
61	SBCK	I	Subcode reading clock input (schmitt input)
62	FSX	O	7.35kHz sync. signal output which is divided the frequency from the crystal resonator.
63	WRQ	O	Standby output of subcode Q output
64	RWC	I	Read / Write control input
65	SQOUT	O	Subcode Q output
66	COIN	I	Command input from the microcomputer
67	CQCK	I	Command input take in clock or subcode take out clock input from SQOUT (schmitt input)
68	RES	I	Chip reset input Once turn to "L" at the power ON
69	TST11	O	Test input pin Open (Normally, output "L")
70	LASER	O	Laser ON/OFF output Control with the serial data command from the microcomputer
71	16M	O	16.9344MHz output However, output 33.8688MHz in the fourfold speed playback mode.
72	4.2M	O	4.2336MHz output
73	CONT	O	Auxiliary output Control with the serial data command from the microcomputer.
74	TEST5	I	Test input pin with pull-down resistor
75	CS	I	Chip select input with pull-down resistor
76	XVSS		Ground for the crystal resonator Normally, 0V.
77	XIN	I	Connect the 16.9344MHz crystal resonator.
78	XOUT	O	Connect the 33.8688MHz crystal resonator in the fourfold speed playback system.
79	XVDD		Power supply for the crystal resonator Normally, 5V.
80	TEST1	I	Test input pin with pull-down resistor

7.1.2 DISPLAY

■ VAW1041 (FLKY ASSY : V101)

● FL TUBE

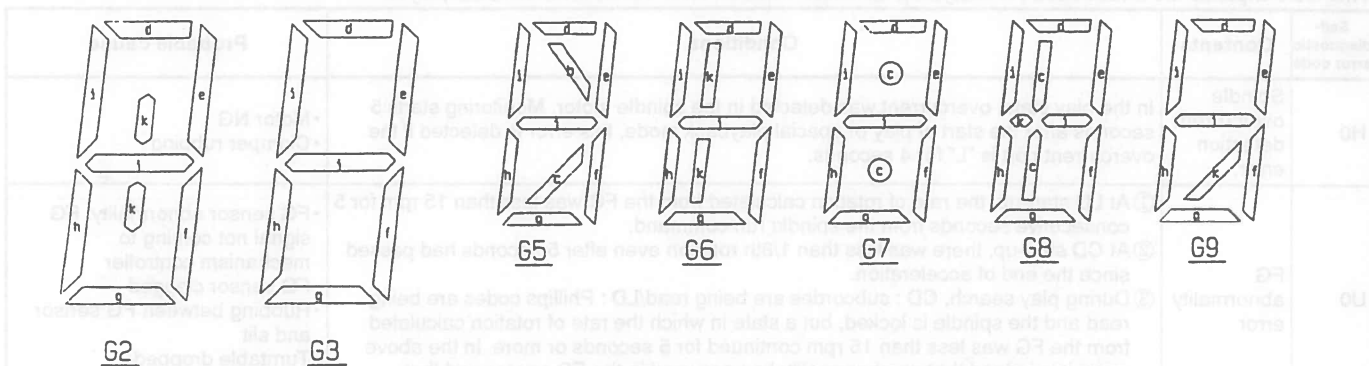
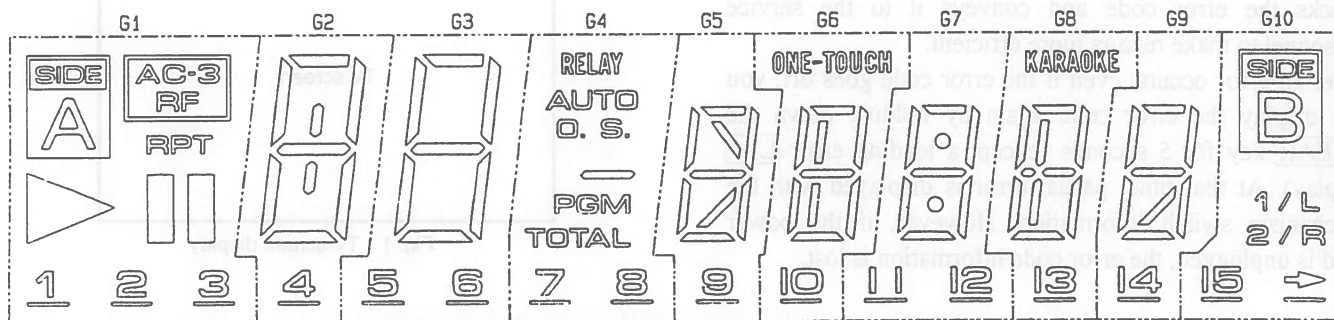

● ANODE GRID ASSIGNMENT & PIN ASSIGNMENT

	G1	G2	G3	G4	G5	G6	G7	G8	G9	G10
P1	<u>1</u>	<u>4</u>	<u>5</u>	<u>7</u>	<u>9</u>	<u>10</u>	<u>11</u>	<u>13</u>	<u>14</u>	<u>15</u>
P2	<u>2</u>	/	<u>6</u>	<u>8</u>	b	ONE-TOUCH	<u>12</u>	KARAOKE	/	→
P3	<u>3</u>	/	/	/	c	/	:	c	/	/
P4	A	d	d	RELAY	d	d	d	d	d	B
P5	△	e	e	AUTO	e	e	e	e	e	1/L
P6		f	f	O.	f	f	f	f	f	2/R
P7	RPT	g	g	S.	g	g	g	g	g	/
P8	AC-3 RF	h	h	-	h	h	h	h	h	/
P9	/	i	i	PGM	i	i	i	i	i	/
P10	/	j	j	TOTAL	j	j	j	j	j	/
P11	/	k	/	/	/	k	/	k	k	/

● PIN ASSIGNMENT

Pin No.	1	2	3	4	5	6	7	8	9	10	11	12	13	14	15	16	17
Assignment	F	F	NP	NL	NL	NL	NL	G1	G2	G3	G4	G5	G6	G7	G8	G9	G10

Pin No.	18	19	20	21	22	23	24	25	26	27	28	29	30	31	32	33	34
Assignment	P1	P2	P3	P4	P5	P6	P7	P8	P9	P10	P11	NL	NL	NL	NP	F	F

F:Filament G1~G10:Grid P1~P11:Anode NP:No pin NL:No Lead

7.2 DIAGNOSIS

7.2.1 SELF-DIAGNOSTIC FUNCTIONS

(1) SELF-DIAGNOSTIC FUNCTIONS

The self-diagnostic functions automatically display an error code on the TV screen and front panel fluorescent display section when there is an error. The customer checks the error code and conveys it to the service personnel to make repairs more efficient.

After an error occurs, even if the error code goes off, you can display the error code again by holding down the **CLEAR** key for 5 seconds (except a loading error **L *** display). At that time, partial error is displayed with the mechanism switch information. However, if the power cord is unplugged, the error code information is lost.

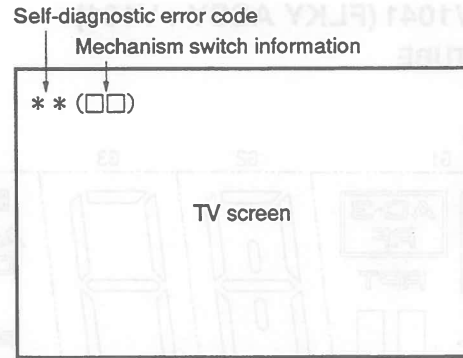

Fig. 1 TV screen display

This table explains the information for analyzing the cause when an error occurs with the CLD player.

Self-diagnostic error code	Contents	Conditions	Probable cause
H0	Spindle overcurrent detection error.	In the play state, overcurrent was detected in the spindle motor. Monitoring starts 5 seconds after the start of play or special playback mode, this error is detected if the overcurrent port is "L" for 4 seconds.	<ul style="list-style-type: none"> • Motor NG • Clamper rubbing
U0	FG abnormality error	<ol style="list-style-type: none"> ① At LD start-up, the rate of rotation calculated from the FG was less than 15 rpm for 5 consecutive seconds from the spindle run command. ② At CD start-up, there was less than 1/8th rotation even after 5 seconds had passed since the end of acceleration. ③ During play search, CD : subcodes are being read/LD : Phillips codes are being read and the spindle is locked, but a state in which the rate of rotation calculated from the FG was less than 15 rpm continued for 5 seconds or more. In the above case, it is judged that an abnormality has occurred in the FG sensor and that accurate rotation rate calculation has become impossible. 	<ul style="list-style-type: none"> • FG sensor abnormality, FG signal not coming to mechanism controller • FG sensor clogged • Rubbing between FG sensor and slit • Turntable dropped • FG slit deposition NG
H1	Partial short error	<ol style="list-style-type: none"> ① At LD start-up, the speed did not reach 1200 rpm within a certain time (12 seconds) after the spindle run command. ② At CD start-up, a certain speed (313 rpm) was not reached within 6 seconds from the end of spindle acceleration. 	<ul style="list-style-type: none"> • Spindle motor NG • Commutator NG • Bearing too tight • Power supply NG
H2 A0	Power supply abnormality error	<p>– 5V power supply abnormality detected.</p> <p>The power supply abnormality port is constantly monitored and if its signal stays high for about 1 second consecutively, the power supply is judged to be abnormal.</p>	<ul style="list-style-type: none"> • – 5V not fed from POWER SUPPLY assy • Parts shorted
L *	Loading error	<ol style="list-style-type: none"> ① When loading operation goes over time (approx. 10 sec.). ② When assist at disc sense entry ends and is not tilt neutral. ③ When assist at set up entry ends and is not tilt neutral. 	<ul style="list-style-type: none"> • Tilt switch 1, 2, 3 abnormal, so tilt/loading state not read in correctly • Tilt/loading mechanism mechanically locked • Drive IC NG • Power supply NG
E *	Slider error	During slider movement, a time over-run occurred (track count search 20 seconds, mandatory movement 10 seconds)	<ul style="list-style-type: none"> • Slider ceased being able to run • The slider mechanism is mechanically locked and can no longer move to its target. • Slider position switch NG • Flexible cable pulled out • Drive IC NG • Power supply abnormal
U1	Miss clamp error	<ol style="list-style-type: none"> ① During LD setup, after 1/8th rotation, the track count during 1/8 rotation exceeded 511. ② During start-up, the focus was lost once and refocusing was attempted, but the focus could not be locked. ③ Two FG pulses did not come within 800 ms from from the start of LD start-up. ④ The disc clamp operation did not end within 5 seconds. 	<ul style="list-style-type: none"> • Disc sandwiched • Disc shifted • Spindle motor NG • Disc scratched or dirty defocused during start-up • Two discs loaded • PU actuator NG • Tilt sensor NG • Tilt neutral NG (tilt base NG)

Self-diagnostic error code	Contents	Conditions	Probable cause
P *	Spindle error	① During TOC reading with an LD, the spindle servo was not locked within 60 seconds from the start of the spindle run. ② When CAV/CLV determination is not finished within 60 seconds from spindle servo lock. ③ The codes could not be read for 10 – 15 seconds consecutively for an LD or 7 – 10 seconds for a CD/CDV and the spindle servo was not locked. ④ The speed exceeded 2100 rpm during LD start up.	P0 :•PH code, SUB-Q code can not be read •VCO, PLL offset out of adjustment •Disc defect P5:•PAL disc, mirror disc, etc. PLAY •No RF P6:•Spindle servo does not lock •Spindle motor NG
F *	Focus error	① "In the "no disc" state, a setup command was received from the mode controller. ② When LD is out of focus when slider is moved to starting position during set up. In case of CD/CDV is NG even after three focus tries. ③ During start-up, the maximum slider servo duty continued for 3 loops or more.	F5 :•CD, LD on top of each other •LD scratched or dirty defocused during slider movement •Disc NG •Slider position switch NG F6 :•Inner edge of disc scratched or dirty •Slider ran into inner edge mechanical stopper

* Besides the above errors, there is the "U2" communications error (the mode controller could not communicate normally with the mechanism controller)

The probable cause is a defective mechanism controller, disconnected cable, etc..

* Mechanism mode contents (meanig of * for L * etc.)

- | | | |
|----------------|----------------------------|---------------------|
| 0 : Play | 5 : Setup (rotation start) | 9 : Side A → Side B |
| 1 : Open | 6 : TOC read | A : Side B → Side A |
| 2 : Standby | 7 : Play | |
| 3 : Clamp | 8 : Search | |
| 4 : Disc sense | | |

(2) FORMAT OF THE MECHANISM SWITCH INFORMATION WHICH IS TRANSMITTED TO THE MODE CONTROL IN THE ERROR OCCURENCE

● Mechanism switch information (**1 7**)

Mechanism control → Mode control

Communication byte address 5 (COMBUF5)

(Mode control displays this value as it is.)

Example

(**1 7**)

Hexadecimal number system

Hexadecimal number system	Binary number system
0	0 0 0 0
1	0 0 0 1
2	0 0 1 0
3	0 0 1 1
4	0 1 0 0
5	0 1 0 1
6	0 1 1 0
7	0 1 1 1
8	1 0 0 0
9	1 0 0 1
A	1 0 1 0
B	1 0 1 1
C	1 1 0 0
D	1 1 0 1
E	1 1 1 0
F	1 1 1 1

Example

Hexadecimal number system

Example

1

Example

7

Binary number system

0 0 0 1 0 1 1 1
bit 7 bit 6 bit 5 bit 4 bit 3 bit 2 bit 1 bit 0

TURN A	0 Not used	LTSW1	LTSW2	LTSW3	SLDP1	SLDP2	SLDP3
--------	---------------	-------	-------	-------	-------	-------	-------

TURN A	Slider position
0	Side B
1	Side A

Example of **1 7** is indicated as follows.

- (Slider : Side B
- Tilt : Tilt +
- Position : B-INSIDE

LTSW			Loading/tilt position
1	2	3	
0	1	1	Open (Tray open state)
0	0	1	Loading (During move the tray horizontally)
1	0	1	Standby (Tray close & spindle down state)
1	0	0	Clamp (Durring spindle up or down)
0	0	0	Tilt - (Clamp state)
0	1	0	Tilt + (Clamp state)
1	1	0	Tilt limit (Clamp state)

SLDP			Slider position
1	2	3	
1	0	0	CD active position
1	0	1	CDV active position
1	1	0	LD active position
0	1	1	CD inside position
1	1	1	Side B inside position

7.2.2 AGEING MODE (エージングモード)

AGEING MODE: ON

•Note for KARAOKE model : Set the SINGLE PLAY (一曲停止) mode to OFF.

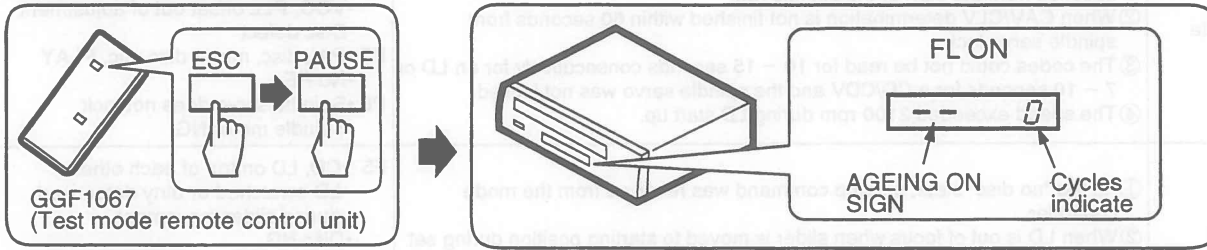

AGEING

• LD

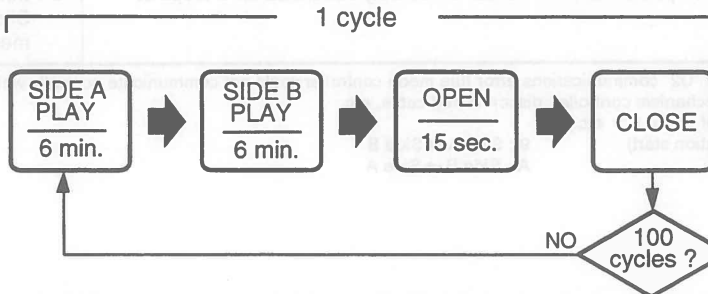

• CD, CDV

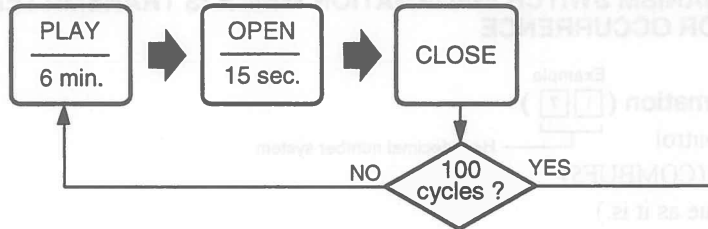

• NO DISC

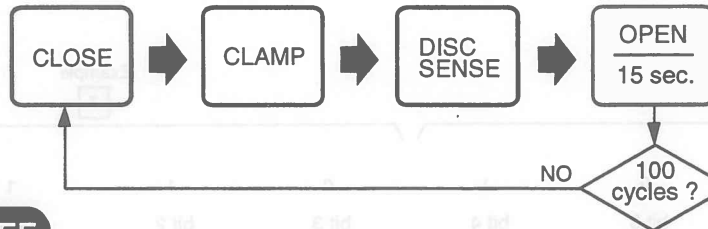

AGEING MODE: OFF

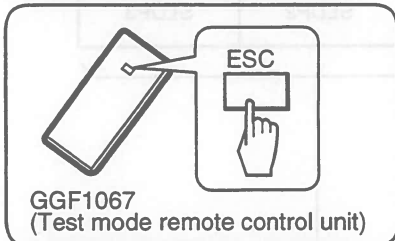

GGF1067 (Test mode remote control unit)

ERROR OCCURRED

ERROR OCCURED : エラー発生

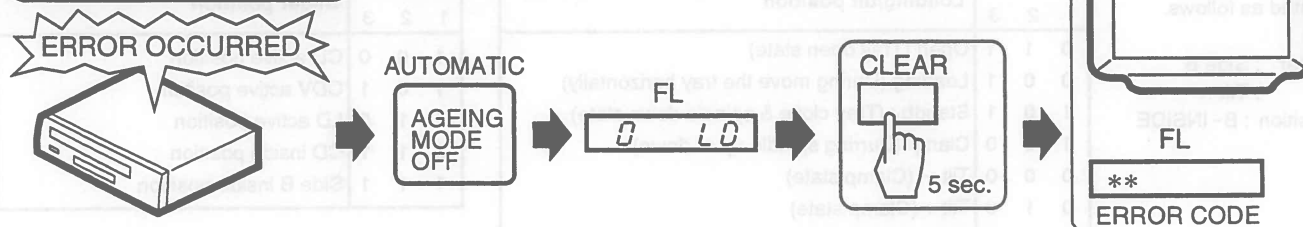

7.2.3 DISASSEMBLY/ASSEMBLY (分解/組立の手順)

(1) DISC TRAY

- Disassembly : ① → ② → ③ → ④ → ⑤
- Assembly : ⑤ → ①

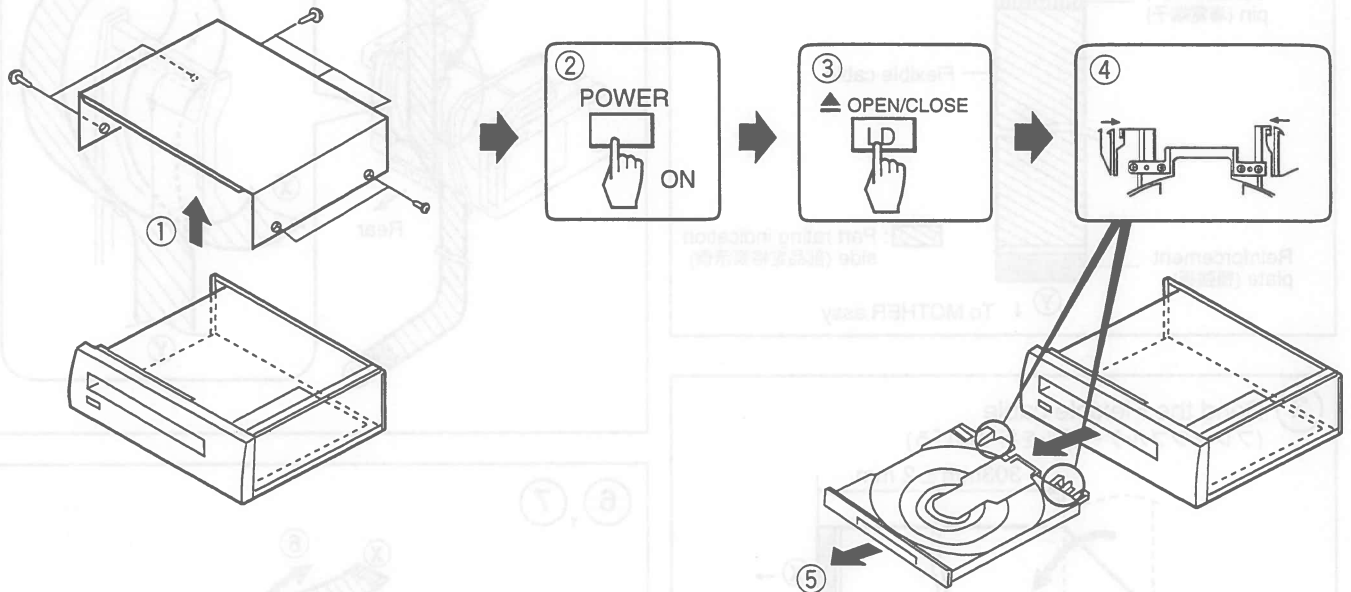

(2) MOTHER ASSY

- Disassembly : ① → ② → ③ → ④ → ⑤ → ⑥
- Assembly : ⑥ → ⑤ → ④ → ③ → ② → ①

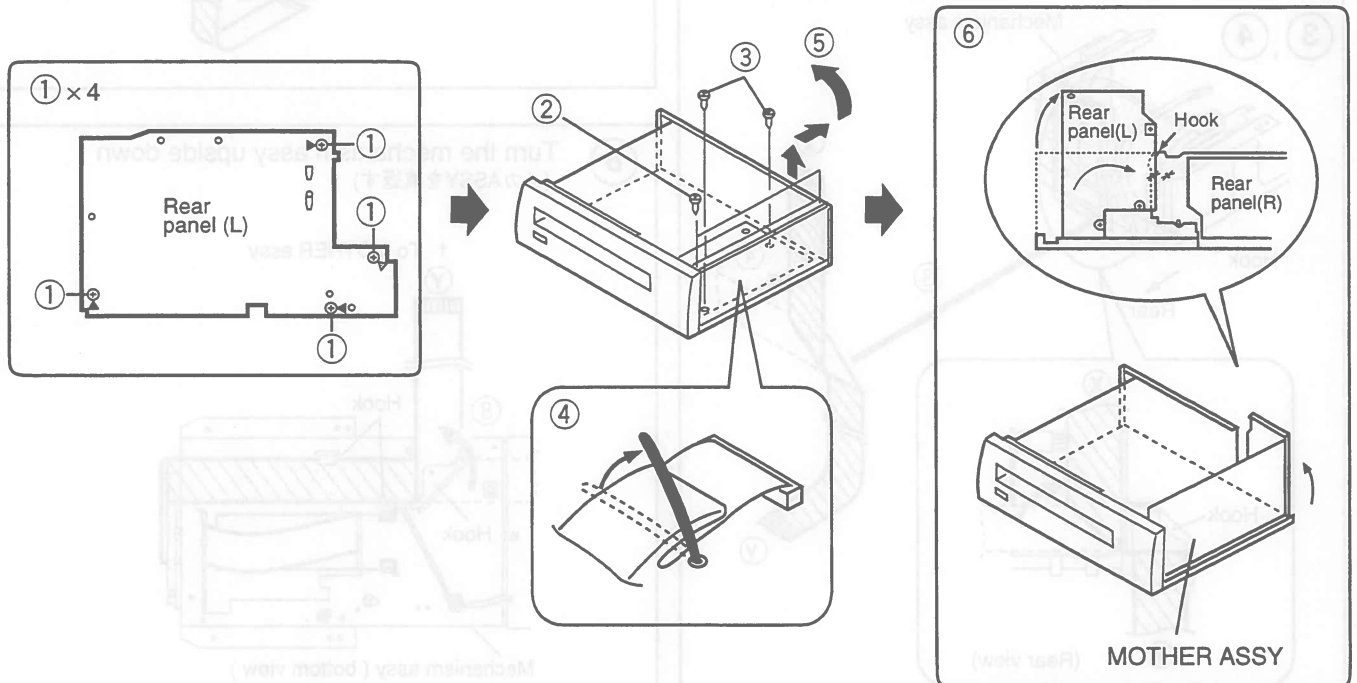

(3) HOW TO INSTALL THE FLEXIBLE CABLE FOR CARRIAGE ASSY

(キャリッジASSY用フレキシブルケーブルの取付方法)

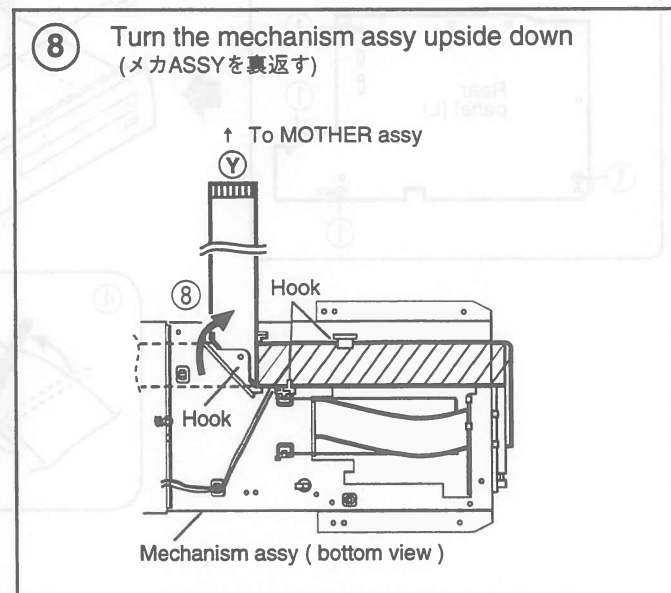
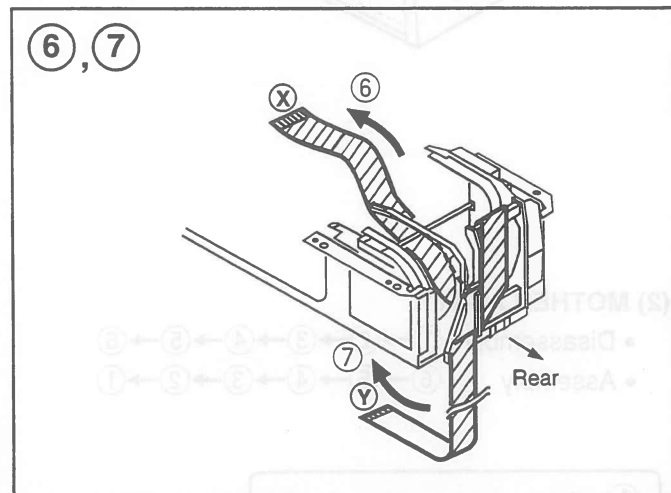
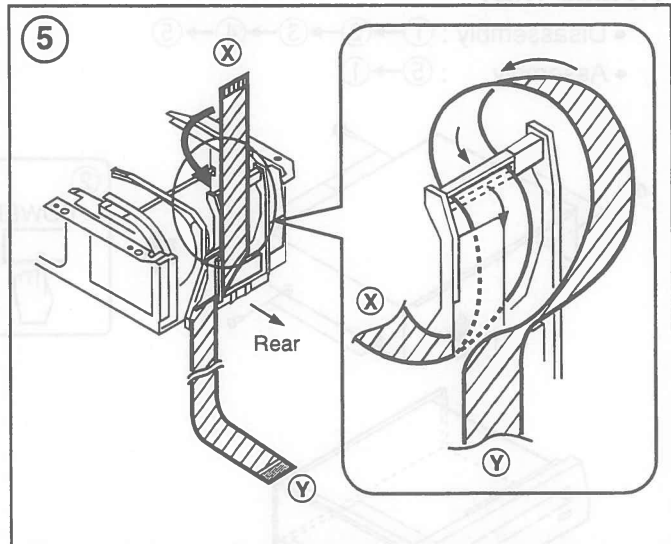
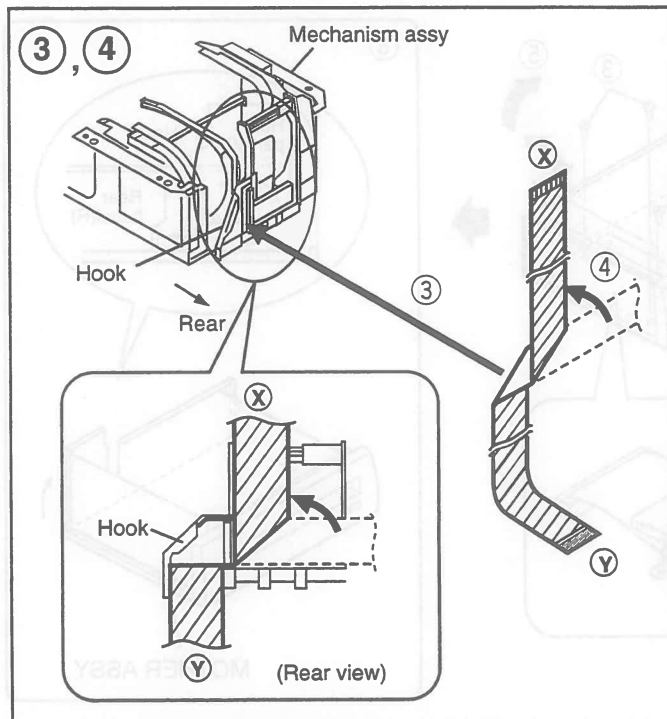
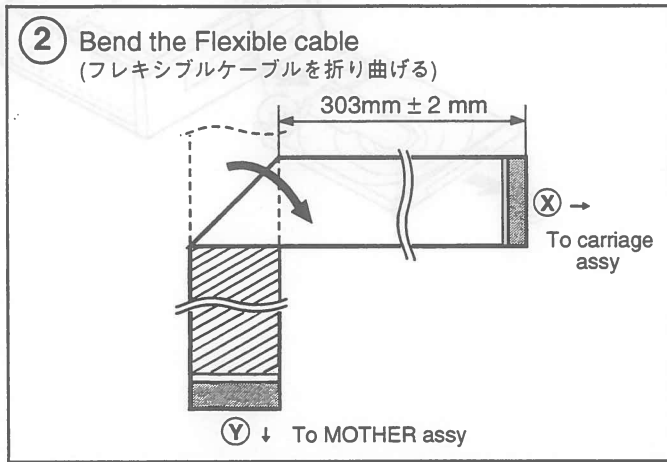
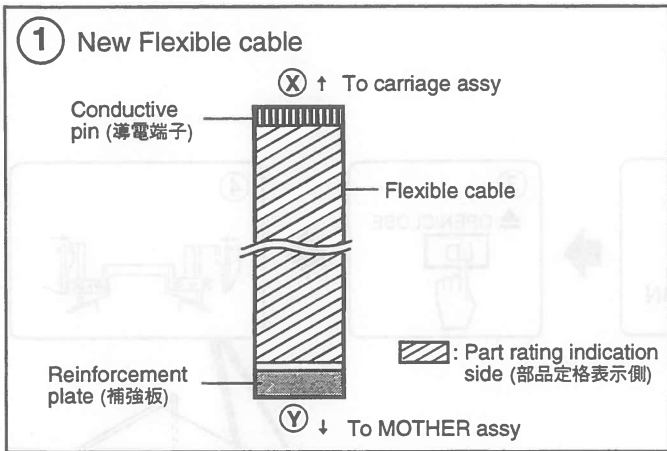

7.3 EXPLANATION
7.3.1 BLOCK DIAGRAM
(1) OVERALL BLOCK DIAGRAM

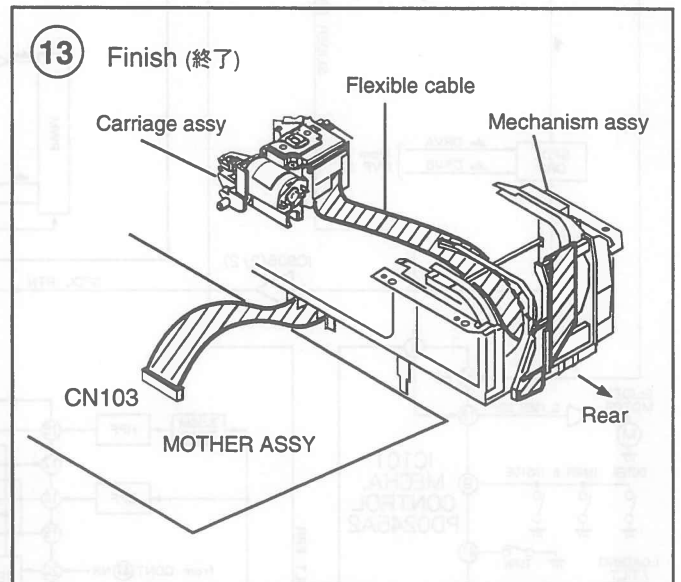
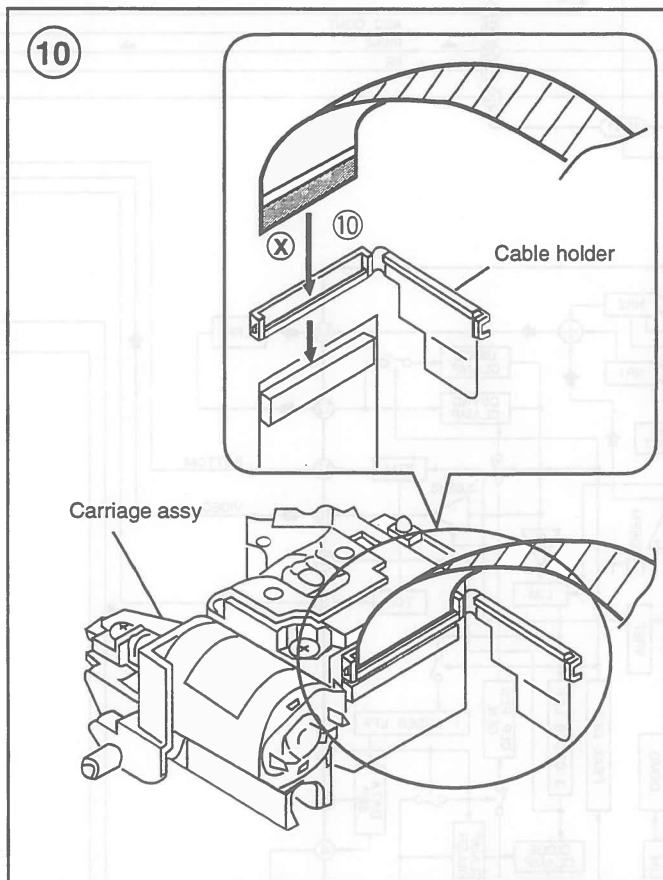
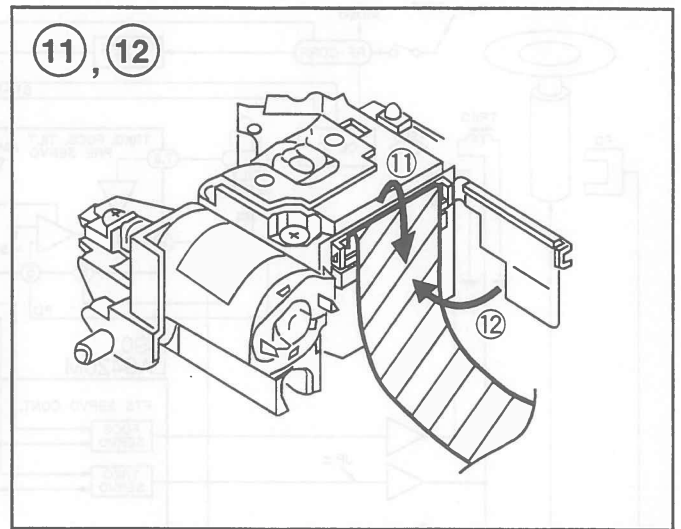
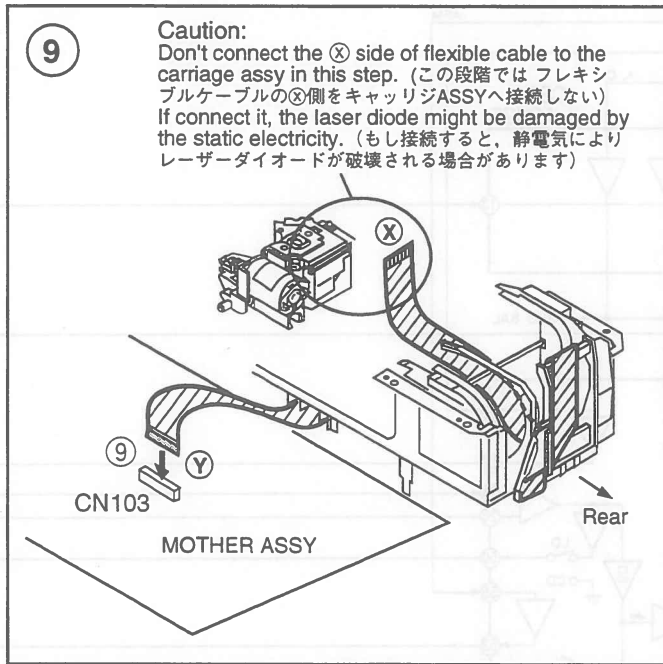

7.3 EXPLANATION

7.3.1 BLOCK DIAGRAM

(1) OVERALL BLOCK DIAGRAM

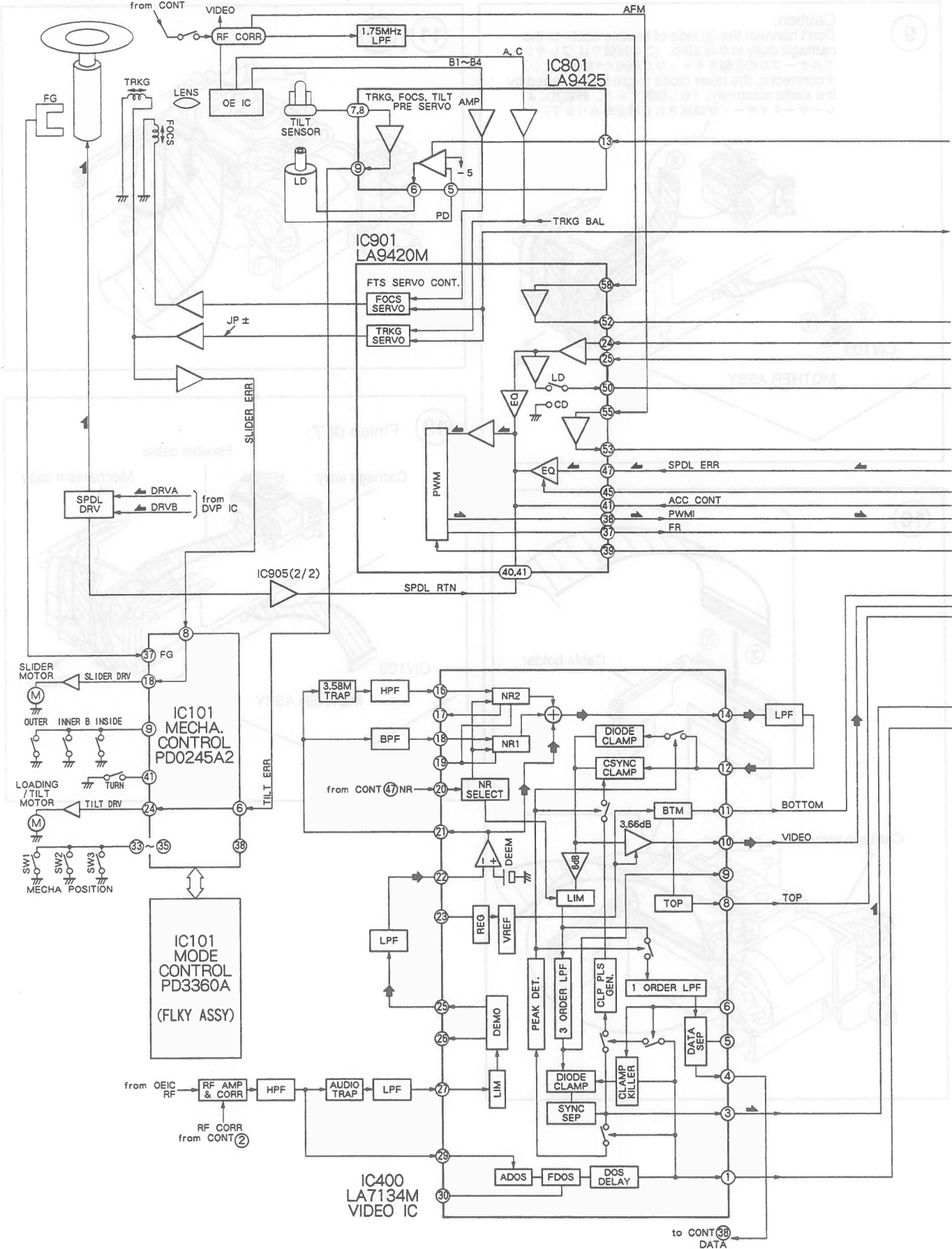

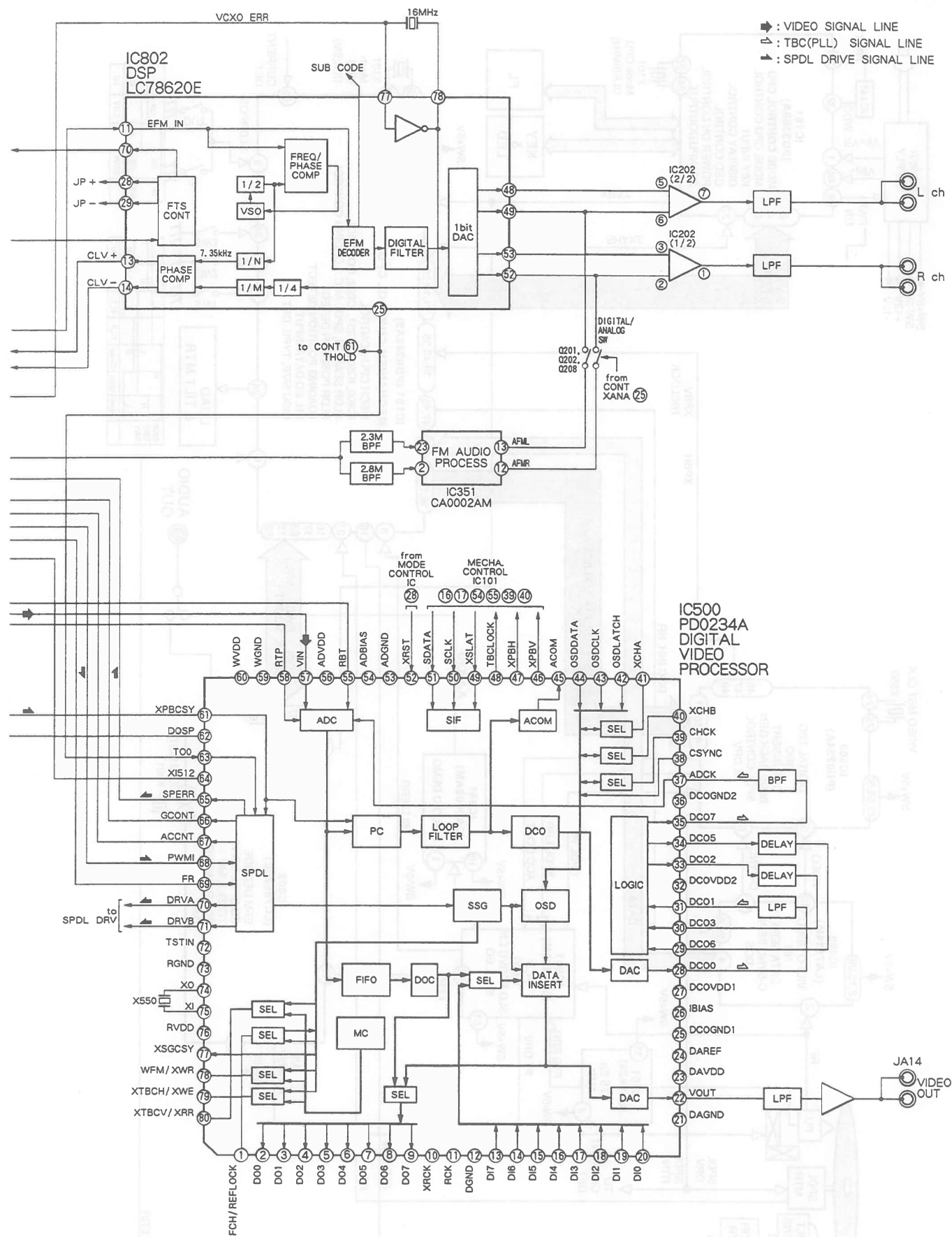

(2) SYSTEM BUS BLOCK

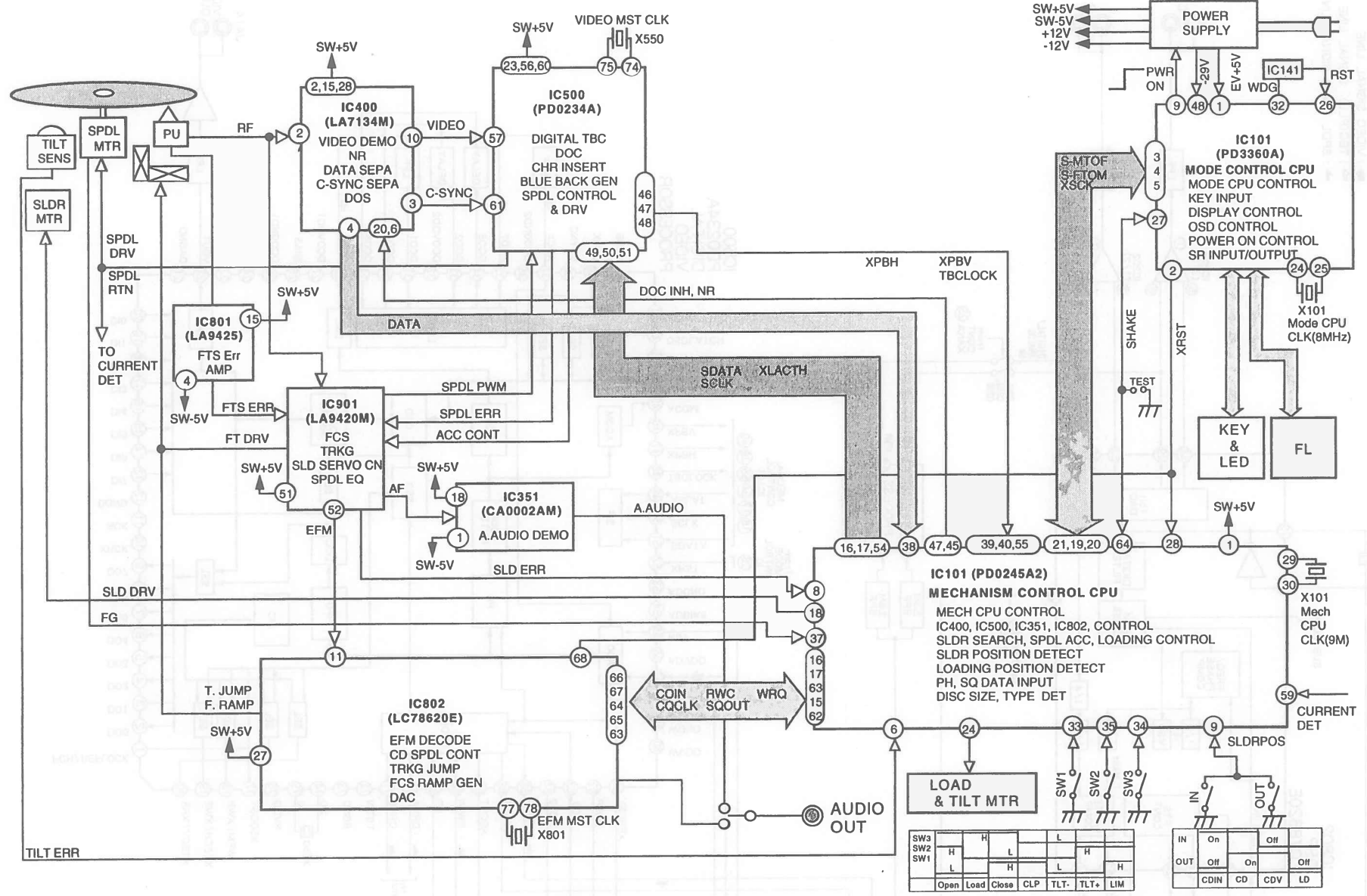

SW3	H	H	L	L		
SW2					H	
SW1	L		H	L		H
	Open	Load	Close	CLP	TLT-	TLT+ LIM

IN	On	Off	
OUT	Off	On	Off
	CDIN	CD	CDV LD

(3) FOCUS SERVO BLOCK

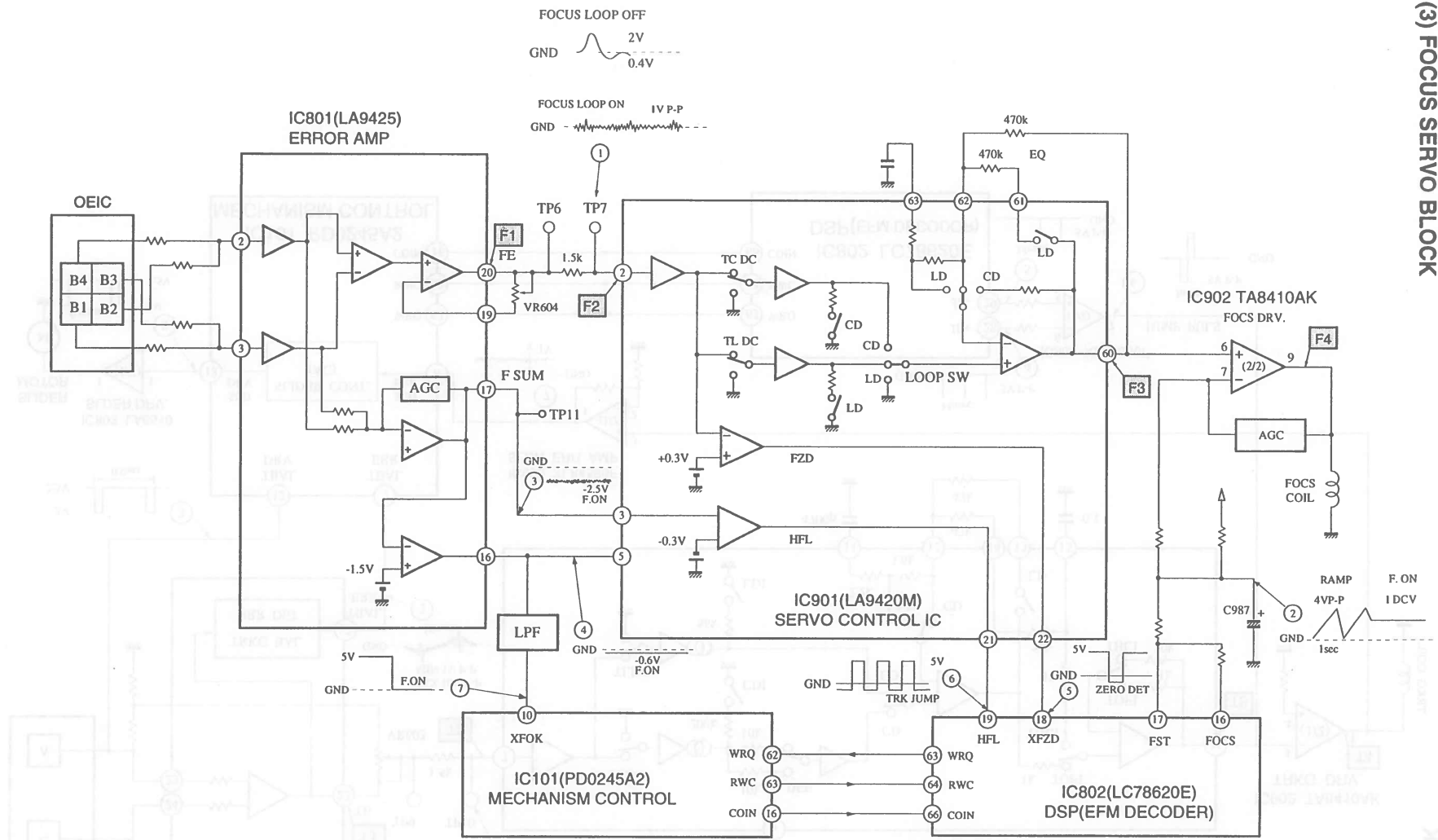

(4) TRKG & SLDR BLOCK

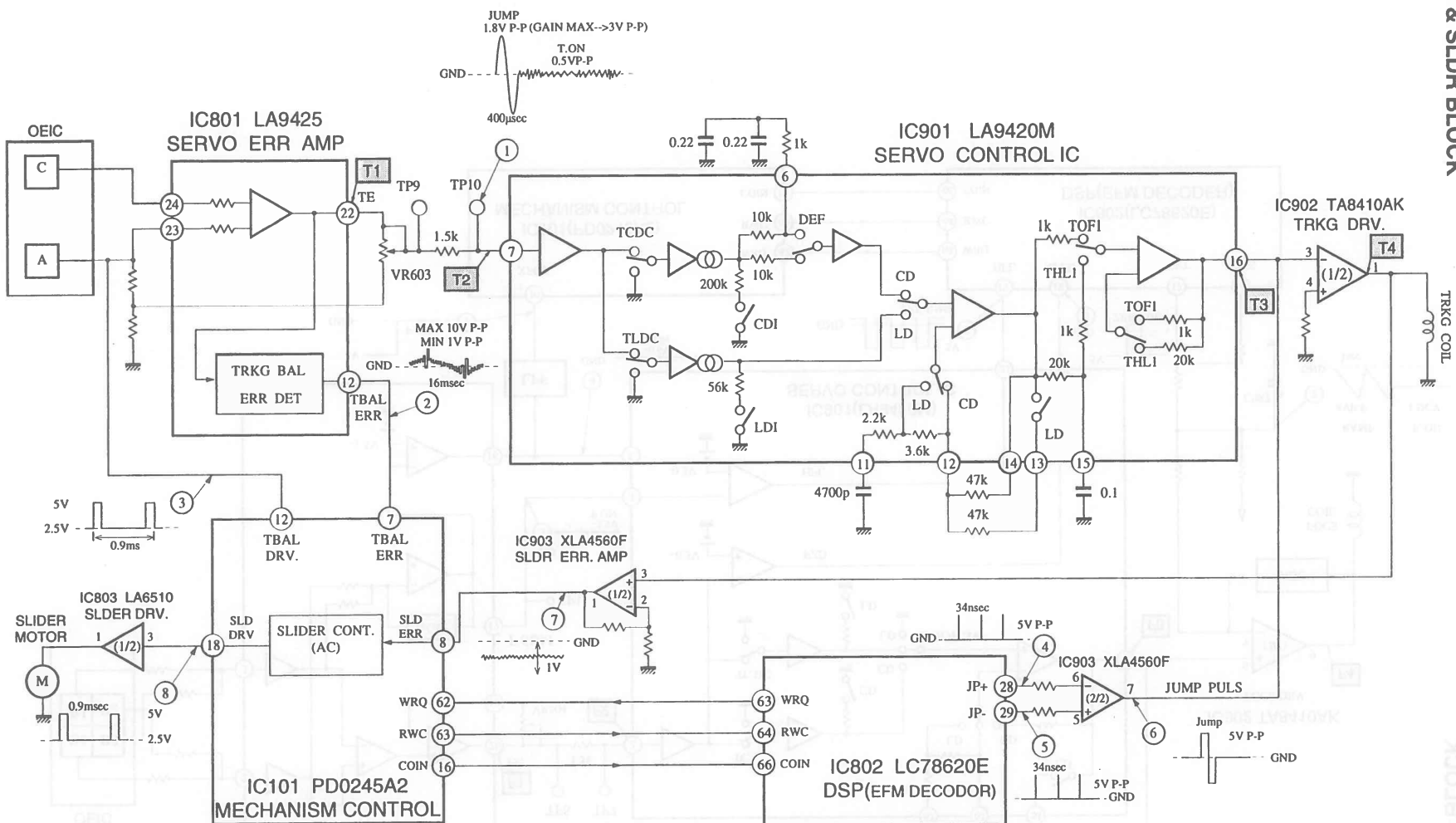

(5) VIDEO & TBC BLOCK

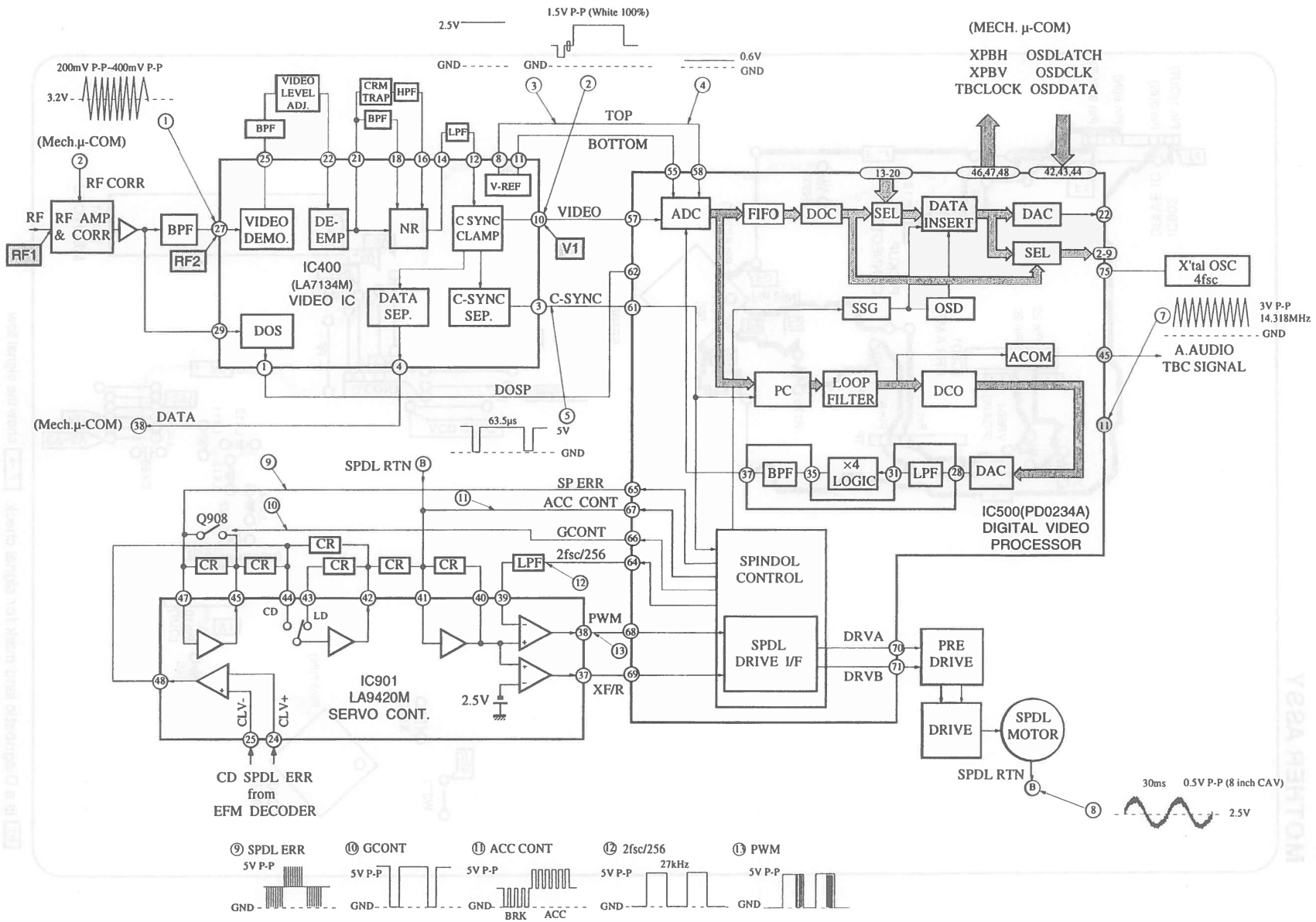

MATTAR DAA KRAN DAA JITSOMDAID S.S.T
YASA BERTON

7.3.2 DIAGNOSTIC LAND MARK AND PATTERN
MOTHER ASSY

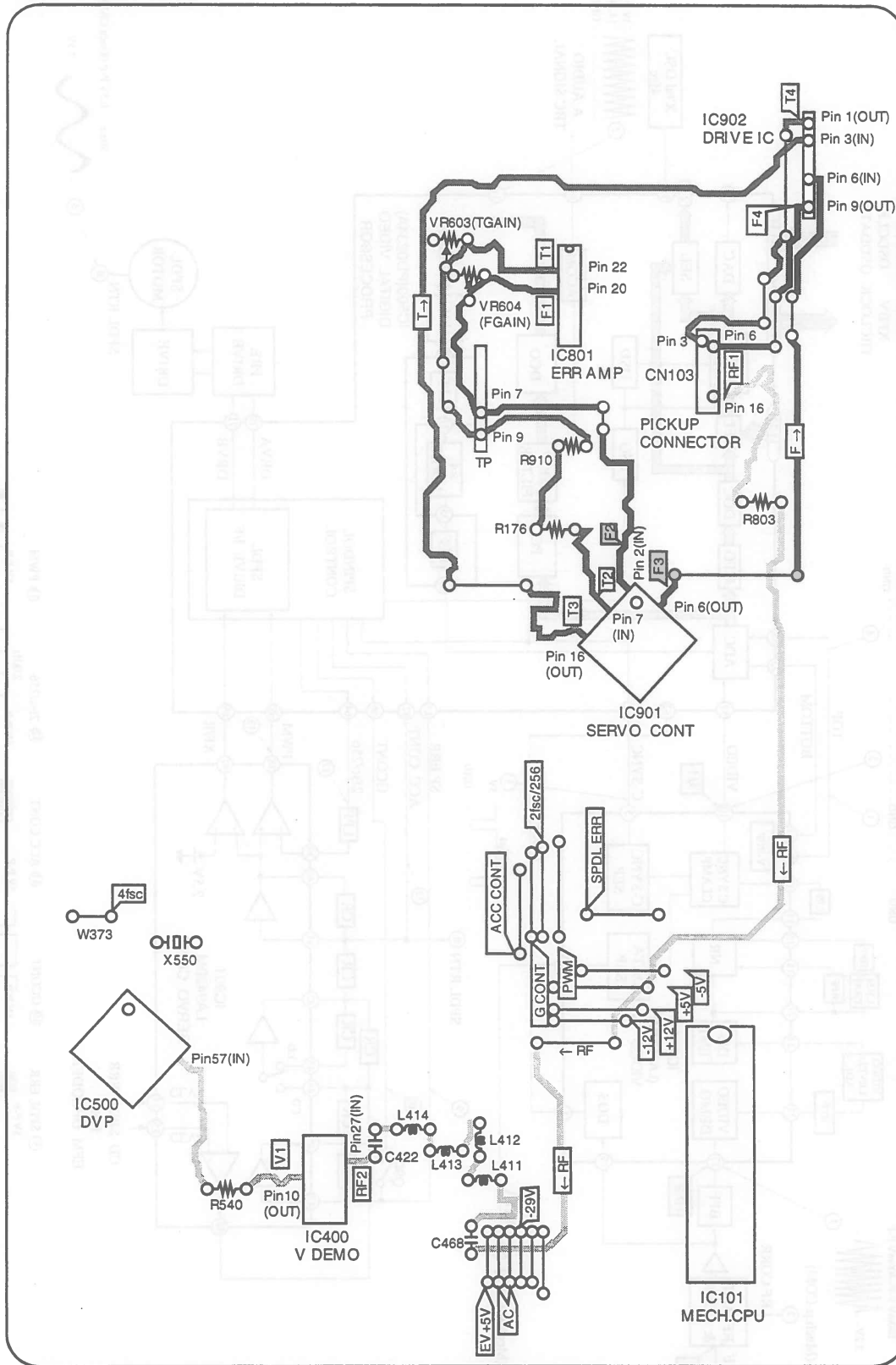

[F1] is a Diagnostic land mark for signal check. [F→] show the signal flow.
—— : FOCUS SERVO system.....Signal flow : F1 → F2 → F3 → F4
—— : TRKG SERVO system.....Signal flow : T1 → T2 → T3 → T4
—— : RF and VIDEO system.....Signal flow : RF1 → RF2 → V1

8. PANEL FACILITIES AND SPECIFICATIONS

■ PANEL FACILITIES

FRONT

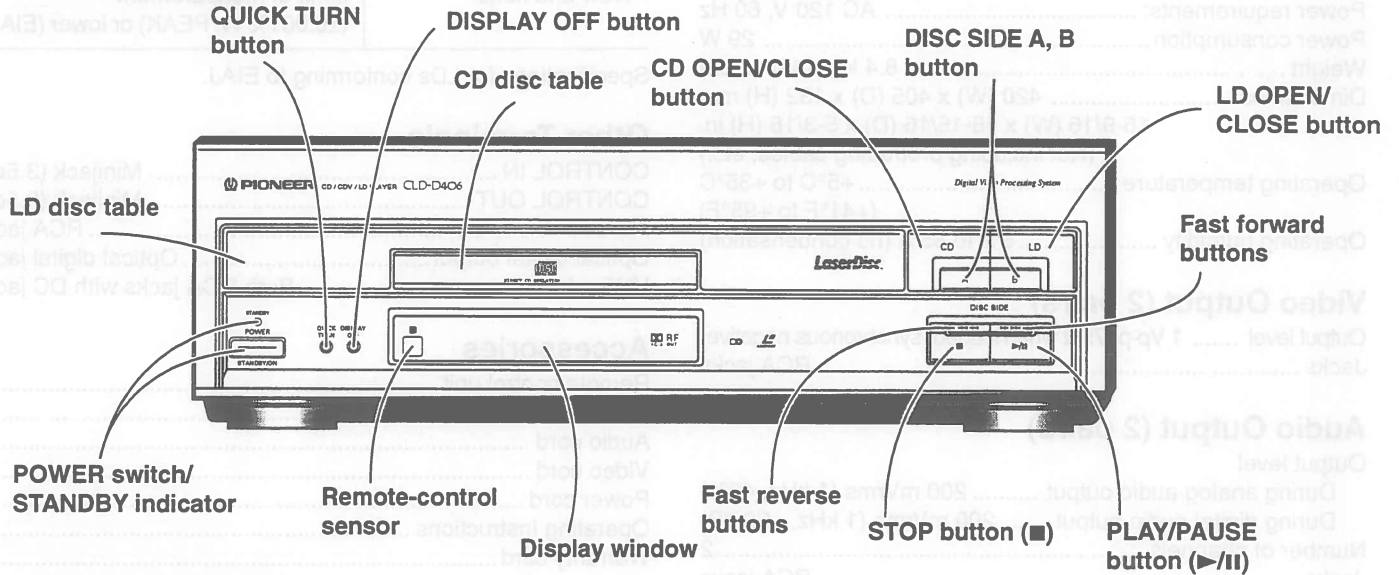

DISPLAY

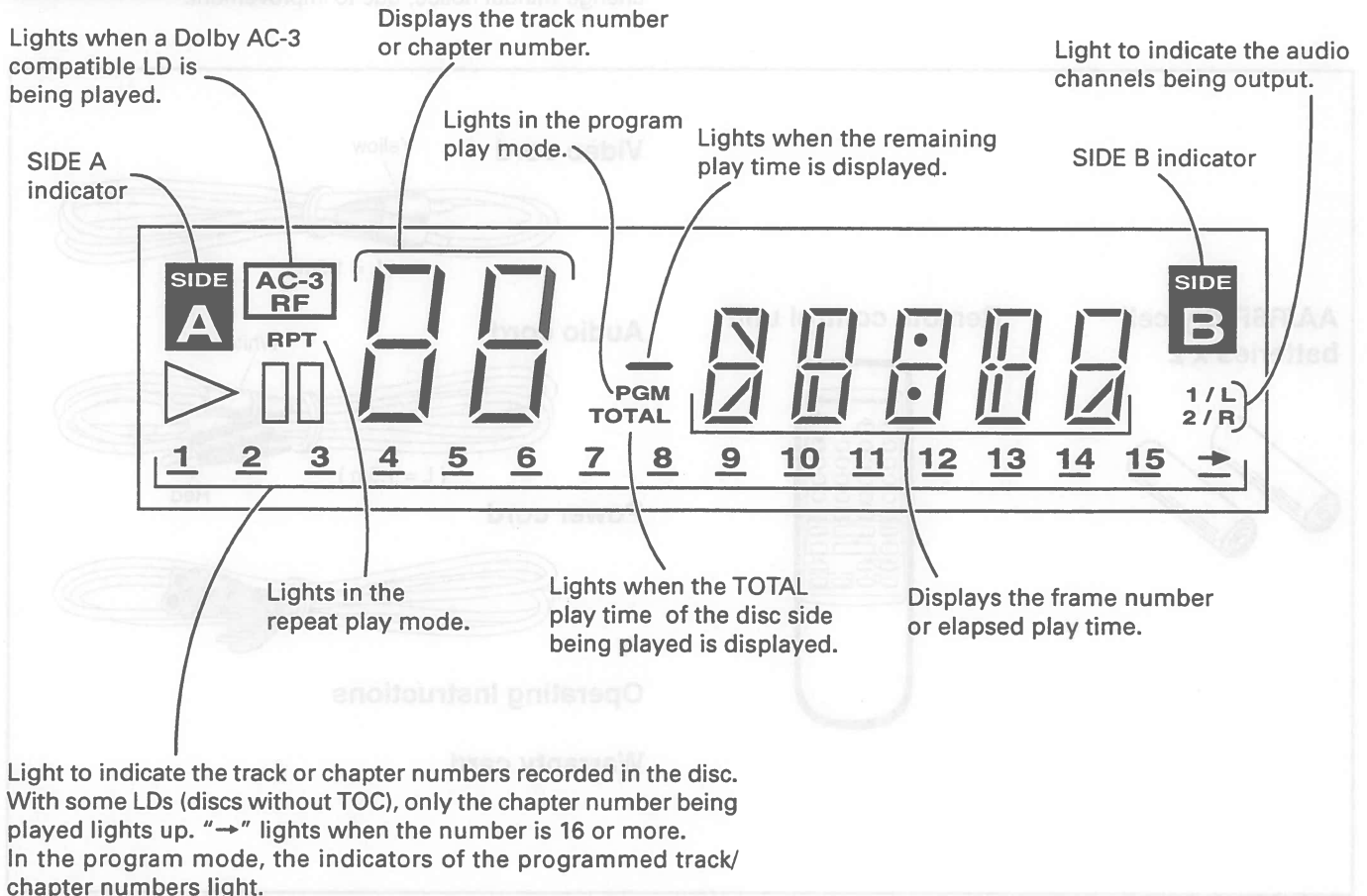

■ SPECIFICATIONS

General

System LaserVision Disc system and Compact Disc digital audio system
 Laser Semiconductor laser: wavelength 780 nm
 Power requirements: AC 120 V, 60 Hz
 Power consumption 29 W
 Weight 6.4 kg (14lb 12 oz)
 Dimensions 420 (W) x 405 (D) x 132 (H) mm
 16-9/16 (W) x 15-15/16 (D) x 5-3/16 (H) in.
 (Not including protruding cables, etc.)
 Operating temperature +5°C to +35°C
 (+41°F to +95°F)
 Operating humidity 5% to 85% (no condensation)

Video Output (2 pairs)

Output level 1 Vp-p (75Ω when loaded, synchronous negative)
 Jacks RCA jacks

Audio Output (2 pairs)

Output level
 During analog audio output 200 mVrms (1 kHz, 40%)
 During digital audio output 200 mVrms (1 kHz, -20 dB)
 Number of channels 2
 Jacks RCA jacks

Digital audio characteristics

Frequency response	4 Hz to 20 kHz
S/N ratio	102 dB (EIAJ)
Wow and flutter	Limit of measurement (±0.001% W. PEAK) or lower (EIAJ)

Specifications for LDs conforming to EIAJ.

Other Terminals

CONTROL IN Minijack (3.5ø)
 CONTROL OUT Minijack (3.5ø)
 AC-3-RF OUTPUT RCA jack
 Optical digital output Optical digital jack
 VHF adapter Both RCA jacks with DC jack

Accessories

- Remote control unit 1
- AA/R6P dry cell batteries 2
- Audio cord 1
- Video cord 1
- Power cord 1
- Operating Instructions 1
- Warranty card 1

NOTE:

The specifications and design of this product are subject to change without notice, due to improvement.

