

Roland

Refer to the leaflet
for using the
UTILITY DISK.

GS SOUND CARD

SCC-1

OWNER'S MANUAL



■ *Before You Begin*

Thank you for purchasing the Roland SCC-1.

The SCC-1 is a GS sound source containing a variety of high-quality sounds built onto a computer expansion card. To fully appreciate all the superior features of the SCC-1 and to ensure years of trouble-free service, please take the time to read this manual in its entirety.

■ *Main Features*

The SCC-1 is a MIDI processor and sound source rolled into one.

● **Sound Source**

◆ **The SCC-1 sound source conforms to the new GS Format developed by Roland.**

The GS Format was devised so that MIDI sound sources will play roughly the same sounds when identical MIDI message is sent to them. In this way, song data written for one GS-compatible sound source can be played through a different sound module, and yet sound almost exactly the same; it doesn't matter what the other sound module is, as long as it is also GS-compatible.

◆ **A maximum of 24 notes (voices) can be played simultaneously.**

You can write music using lots of different sounds by using all the tones available on the SCC-1.

◆ **Reverb and Chorus effects are built-in.**

These effects can add a sense of spaciousness to the sounds on the SCC-1, or make one instrument sound like a whole ensemble.

● **MIDI Processing Unit**

The SCC-1 MIDI Processing Unit converts computer data into MIDI message and vice-versa. It also controls the sound source. You can use the included MIDI converter cable to connect your computer with external MIDI devices and then exchange data with them.

■ *Types of Computers Compatible With the SCC-1*

IBM PC/XT/AT or compatible with half-size 8 bit Slot

IBM PS/1 with Adaptor Card Unit

IBM PS/2 Models 25, 30, 45 or similar ISA-type machines

IBM is a registered trademark of the International Business Machines Corporation.

IBM PC, IBM XT, IBM AT, Personal System/1, PS/1, System/2 and PS/2 are trademarks of the International Business Machines Corporation.

■ Contents

1. Before Using the SCC-1	3
Important Notes	3
Part Names	4
2. Installation	5
3. Making the Connections	7
4. Turning the Power On	9
5. Structure and Function of the SCC-1	10
Parts	10
<GS format background>	10
How to Change Tones	11
Alternate Voicings	11
General Use Areas and Special Use Areas	13
Chorus and Reverb	14
A Part for Drums	14
Changing Between Drum Sets	15
6. Parts and Voices	16
Number of Notes You Can Play at Once	16
What Happens When You Try To Play Too Many Notes	16
7. Appendices	18
Changing Interrupt Levels and I/O Addresses	18
Troubleshooting	19
About MIDI	19
Initial Settings	21
Tone Table	22
Drum Set Table	27
Block Diagram	29
MIDI Implementation	30
Specifications	38

© 1991 Roland

All rights reserved. No part of this publication may be reproduced in any form without the permission of Roland Corporation.

1

Before Using the SCC-1

Important Notes

[Power Supply]

- When making any connections with other devices, always turn off the power to all equipment first; this will help prevent damage or malfunction.
- Do not use this unit on the same power circuit with any device that will generate line noise, such as a motor or variable lighting system.

[Placement]

- Do not subject the unit to temperature extremes (e.g. direct sunlight in an enclosed vehicle). Avoid using or storing the unit in dusty or humid areas or areas that are subject to high vibration levels.
- Using the unit near power amplifiers (or other equipment containing large transformers) may induce hum.

[Additional Precautions]

- Protect the unit from strong impact.
- Do not allow objects or liquids of any kind to penetrate the unit. In the event of such an occurrence, discontinue use immediately. Contact qualified service personnel as soon as possible.
- Should a malfunction occur (or if you suspect there is a problem) discontinue use immediately. Contact qualified service personnel as soon as possible.

Part Names

- SW-2: I/O address dipswitch
This dipswitch is used to change the I/O address.

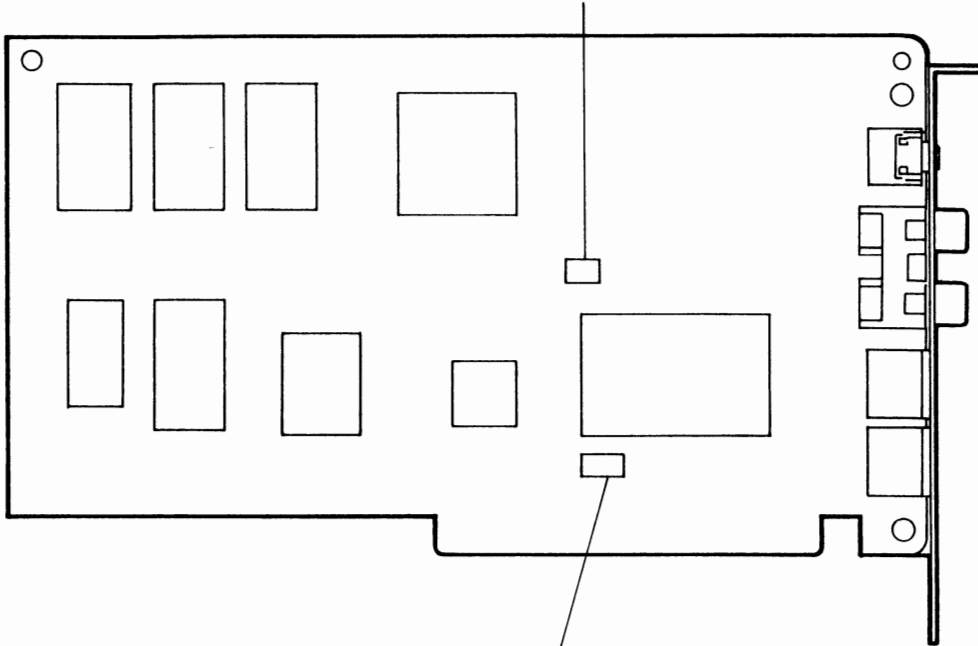

- SW-1: Interrupt Level Jumper Box
This jumper is used to change the interrupt level.

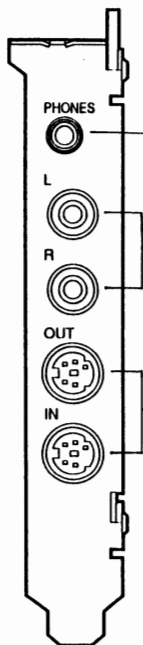

- Headphone jack (mini-stereo plug)
Connect headphones here; The signals will be present at the audio outs even if the headphones are plugged in.
- Audio outs
The SCC-1 can output sounds in stereo (L and R).
- Mini-DIN connectors
Use the included converter cables to connect these mini-DIN terminals with the MIDI connectors used on external MIDI devices.

2 Installation

Installing the SCC-1 in Your Computer.

How you go about installing the SCC-1 will depend on what kind of computer you have. Check your computer's owner's manual for more specific information on installing cards. Here we will use the example of installing the SCC-1 into an IBM PS/1.

● Taking the Cover Off

- ① Turn off the computer and peripherals. Unplug all the equipment from AC power outlets.
- ② Grasp the front panel from the sides and tilt it down as shown in the Figure. The front panel should come right off.

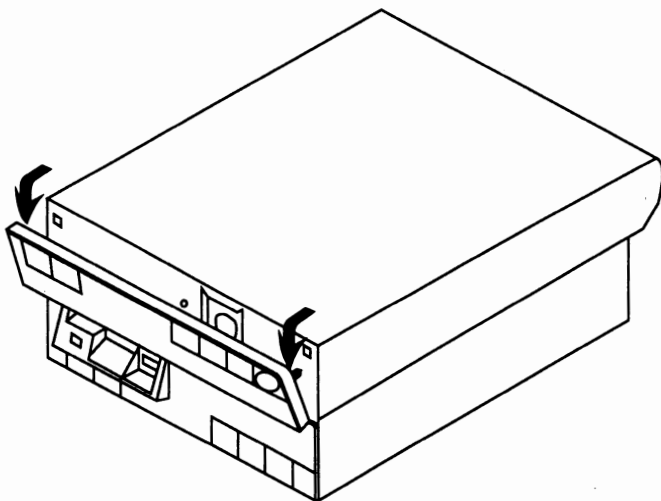

- ③ You should now be able to see the cover latch on the underside of the cover. Pull up on it and slide the cover toward you.

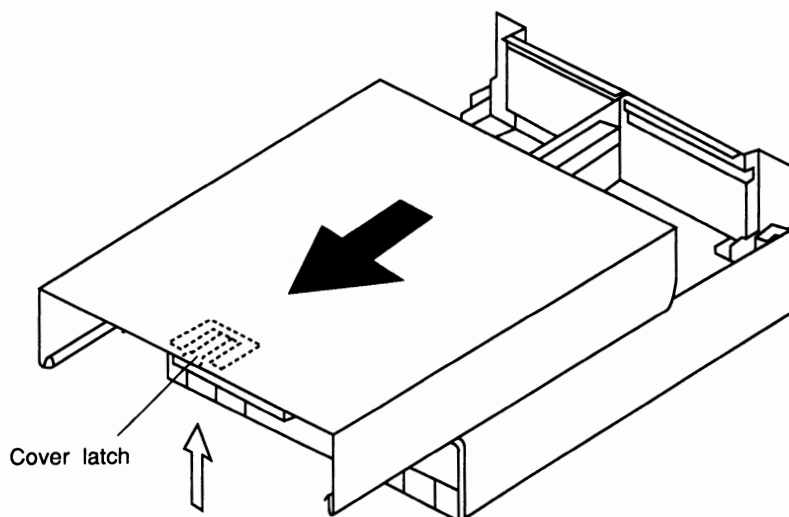

● Installing the SCC-1

- ④ The SCC-1 does not have to be installed in any one particular slot; you can mount it in any unused slot.

Remove the adaptor slot cover for the slot you want to use (This may require removing a screw holding it in place). Insert the SCC-1 into the empty slot as shown and put the screw back in to hold the card in place.

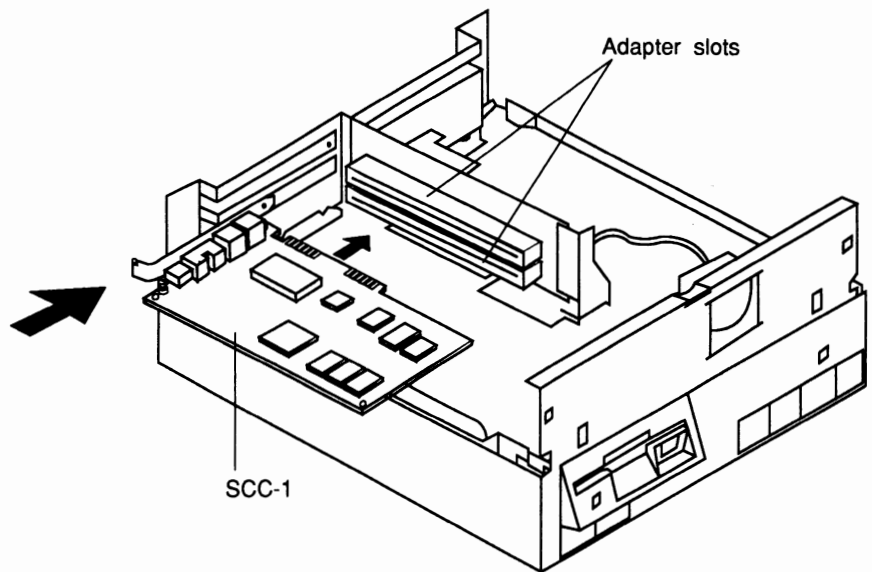
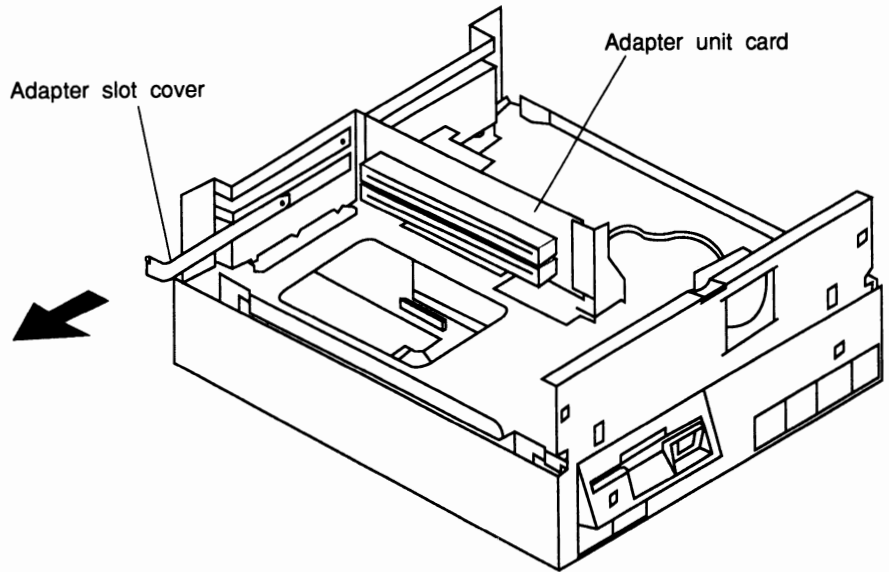

- ⑤ Replace the cover and front panel.

3

Making the Connections

● Connecting the Audio Outs

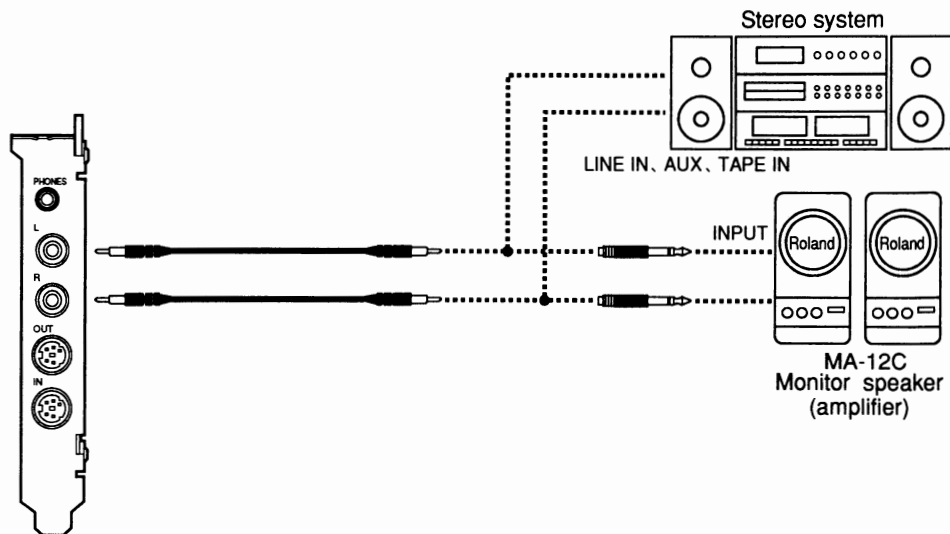

You can use standard audio cables to connect the audio outs of the SCC-1 to the inputs (INPUT, AUX IN, LINE IN, etc.) of any keyboard amp, stereo, cassette player, or whatever. If the inputs are standard RCA audio jacks, you can remove the 1/4" (Phono) plug adapters on the ends of the audio cables that came with the SCC-1 to make the connection.

● Using the Headphones

Use only headphones of 8 to 150 ohms impedance. The sound will be output from the audio outs even if the headphones are plugged in.

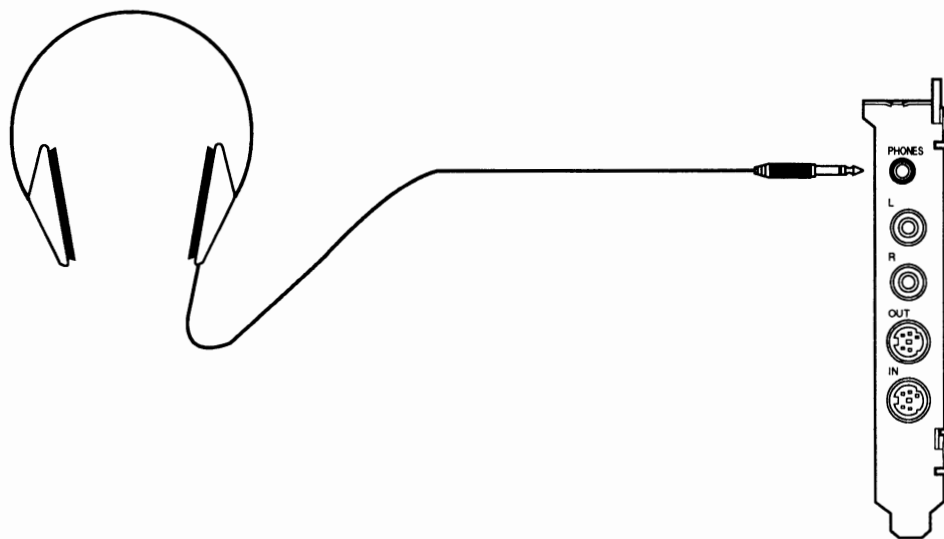

● **Hooking Up the MIDI Connectors With:**

◆ **When Using with a MIDI Keyboard**

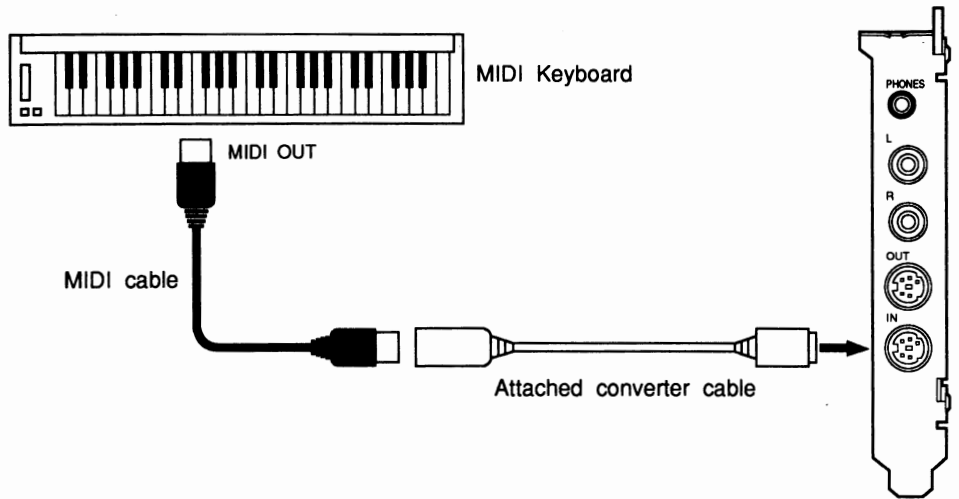

◆ **When Using with an External MIDI Sound Sources**

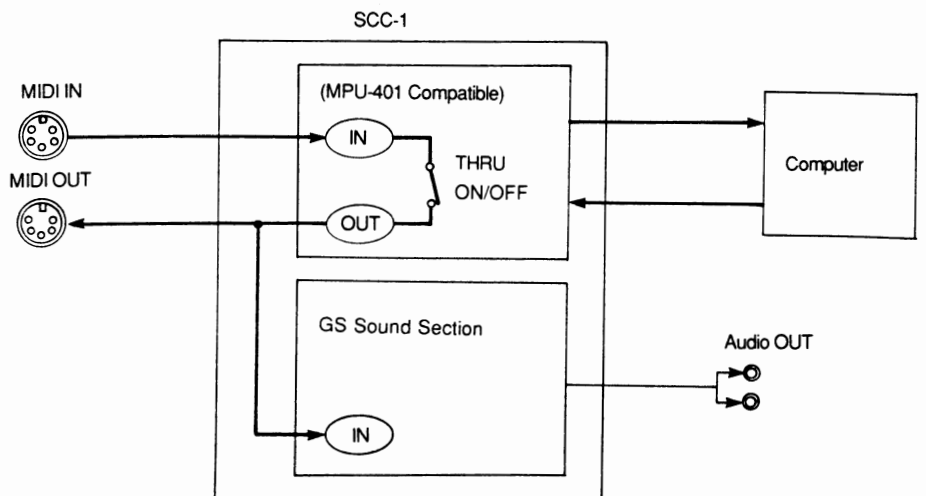
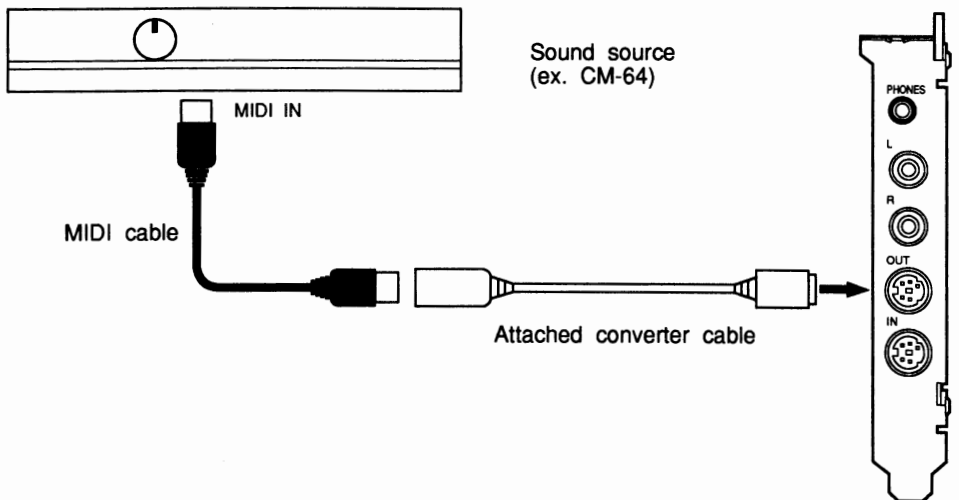

4

Turning the Power On

- ① Before turning the computer back on, check the following.
 - The SCC-1 and all external devices are hooked up correctly.
 - The volume on any amps that are hooked into the setup are turned down.
- ② Turn on the computer.
Start up the software that you want to use.
- ③ Now adjust the amp volume.

Caution: Too high a volume level can damage your speakers. This is especially true of audio equipment: the speakers are usually not as rugged as those in guitar and keyboard amps and are more easily damaged by excessive input levels.

● Turning the Power Off

- ① Turn down the amp volume;
- ② Turn off the peripherals first: audio equipment, amps, etc.;
- ③ Then turn off the computer.

5

Structure and Function of the SCC-1

The SCC-1 sound source conforms to the new GS format. We will be talking about the GS-format in addition to the structure of the SCC-1.

Parts

The SCC-1 can play 16 “parts”. Part number 10 is for playing the rhythm instrument. A part is something like an orchestral part; think of it as a group of musicians all playing a particular instrument. The big difference from a regular orchestra is that you are completely free to decide what kind of instrument they will be playing. In addition, you can change that instrument midway through a song (as many times as you want) for every different part. You could think of this group as being made up of incredible multi-instrumentalists who can play any instrument you give them.

There are many different kinds of performance data in MIDI, but probably the most basic is the note message determining which key to play, how hard, for how long, and when to start. Every part has its own MIDI “channel” over which it receives performance data and, unless you reset it for some reason, the channel number is the same as the part number. Each part plays by following the instructions in the performance data on its own channel, and pays no attention to the data in other channels intended for other parts. So thanks to this MIDI channel scheme, you can play each part completely independently of the others, like on multitrack recorder.

* As to MIDI, refer to “About MIDI” (P.19).

< GS format background >

The MIDI standard came about because people wanted to be able to transmit digital music performance data from one instrument to another, no matter who manufactured it or what kind of instrument it was played on. This compatibility opened up new vistas in the world of electronic musical instruments. Banks of instruments played automatically by sequencers and computer music the way we know it today would not have been possible without MIDI.

In the compromises that finally led to the general acceptance of the MIDI standard, parts of it were left purposely vague. This gave individual manufacturers leeway to design their own features within the overall MIDI standard, but also led to occasional troublesome inconsistencies. For example, there is a standard describing how to send a signal for tone changing using program change message, but because there was no agreement on a standard for the kind of tone generated by a given program change number, this assignment varies randomly from one piece of equipment to the next. In practice, this means that a program change message in the performance data used to play a particular instrument on one sound source will instead play a completely different instrument, or none at all, on a different sound source.

The GS Format concept was developed to resolve this kind of problem. Any sound module certified GS-compatible will correctly play back song data that was written for a different sound module, also certified as GS-compatible (We will call the devices with the GS mark “GS sound sources”).

How to Change Tones

SCC-1 lets it change between a maximum of 16,384 different sounds ("tones") upon command of an external MIDI device (actually, right now there is no sound source that has all of 16,384 different tones, but if there was, it could be done).

In conventional MIDI devices, tones are identified by a "Program Change" number between 1 and 128, which means that you have a maximum of only 128 different tones to choose from. This is hardly enough for the wide variety of sounds you would want to have in a library for even the most basic uses.

The GS Format, however, combines the Program Change number with what is called the "Bank Select" numbers* (of which there are 128) in MIDI, greatly increasing the range of selectable tones.

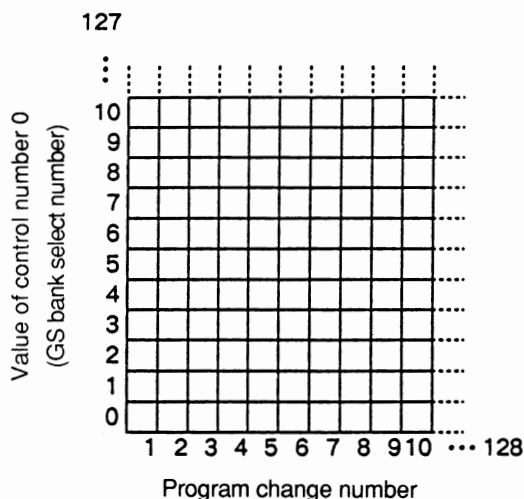

- * Tone numbering is a combination of Bank Select and Program Change message. Although Bank Select messages in MIDI standard consist of Control Change message addresses 0 (MSB) and 32 (LSB), in the GS format it was decided that only the value of 0 (GS Bank Select number) would be used. When a tone is to be changed, the GS Bank Select number is sent first, followed by the Program Change message, when this message is received the tone is changed.

Alternate Voicings.....

No Matter What GS Sound Source You Use, The Song Remains The Same

In the GS Format, tones are organized (roughly by what kind of sound they are) into something called a "tone map". By arranging the tones this way, a song written for one GS sound source will also playback with the same kind of sounds on a different GS sound source.

However, this does not mean that all the spots in the tone map have tones allocated to them; it depends on the sound source. Imagine a situation in which a GS sound source, call it B, is used to play song data that was written for a different GS sound source, A. Suddenly the song data tells B to change to a spot in the tone map that in A was assigned to some neat tone, but where it so happens B has nothing. No sound.

Here is where the GS Format steps in to say “if that particular tone can’t make the performance, give us something that is as close as possible”.
 Let’s Meet the Alternate for the Part

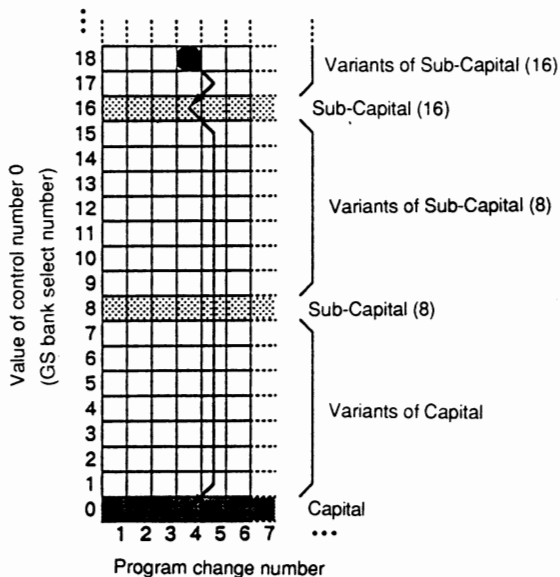

Similar instruments are arranged in the columns of the tone map, and similar kinds of tones are arranged in the horizontal rows. Meanwhile, you’ll find the most basic kind of tones are located at GS Bank Select number 0: these are called “Capitals”. Whatever the GS sound source, some kind of tone will be assigned to every Capital.

Capitals, similar instruments and similar kinds of tones, can be further subdivided into groups based on “nuance”. The representative sounds for this group are found starting at GS Bank Select number 8, and then at every eighth spot in the map. These are called “Sub-Capitals”. Any other sounds are placed on the map above the nuance closest to the Sub-Capital or a Capital as variants of these.

So what happens if we run into the situation described above where tone changing message (GS Bank Select number plus Program Change number) calls for a spot on the tone map that has no tone assigned to it?

For example, let’s send GS Bank Select 18/Program Change 4. If there is a tone at 18/4 in the receiving sound module, of course it plays that sound. But if there is no tone assigned there already, the module goes to the next-in-line Sub-Capital at 16/4 and plays using that sound. Or, if there is no tone assigned there either, it moves all the way down to the Capital at 0/4 and plays that sound (remember, all GS sound sources have tones at the Capitals). Using this rule, no matter what tone number gets sent, you will always get something that, like an alternate for a part, at least sounds similar. The problem we had with disappearing tones between the A and B sources is solved.

Check out the diagram below to see how this scheme is related to the GS Bank Select number.

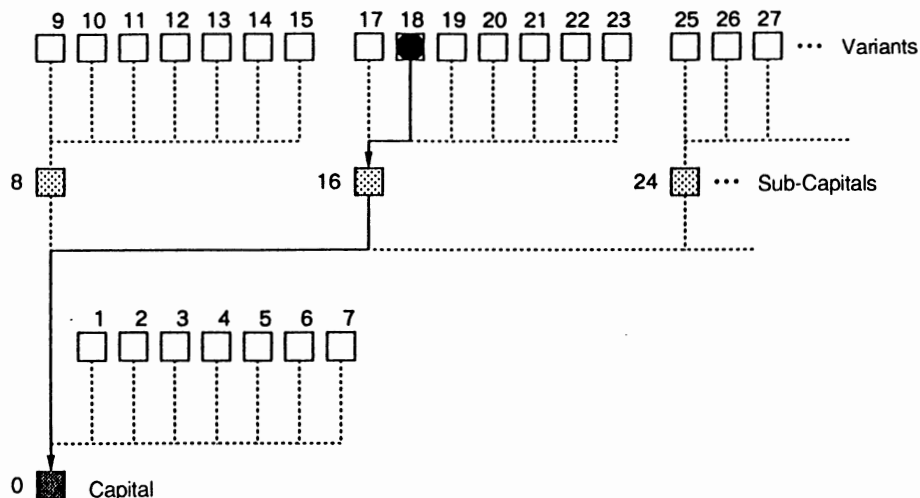

If there is no tone assigned at the indicated location, run down the chart through the Sub-Capitals to the Capitals until you find one that will play. So even if the very same tone is not on the sound source, it will use Alternate Voicing to play the part using a tone with a similar instrument and same kind of sound.

General Use Areas and Special Use Areas

The lower half of the tone map (GS Bank Select numbers 0-63) is a general use area, and the upper half (GS Bank Select numbers 64-127) is a special use area. The special use area is for entering sounds that you concoct yourself, or for special tones on a particular device. A variety of special-effect sounds are also assigned to the general use area, in the range of Program Change numbers from 121 to 128.

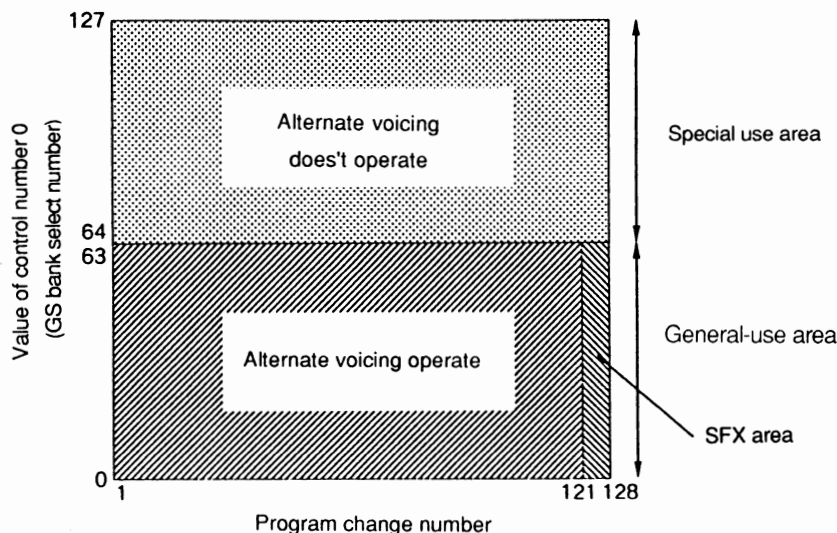

Since the contents of the special use area can be so different from one device to the next, even among GS sound sources, the Alternate Voicing rules we talked about don't apply here. That is, if the indicated tone location happens to be empty, no sound is played. The GS Format also includes a place in the general use area for special effects sounds (SFX). From one spot to another in the tone map there is an incredible variety of sounds.

This means of course that, if we tried to use Alternate Voicing here, we might get a dog barking where we asked for a cat meowing - not at all similar sounds! And so Alternate Voicing doesn't operate here either.

Chorus and Reverb

Every part in a GS sound source can have chorus or reverb effects added to it, and the depth of effects can be controlled in real time using Control Change message.* The Control Change number used for this is standardized in the GS Format, so that no matter what GS sound source you're using, the right kind of effect will turn on or off.

* Control Change 91 controls the depth of Reverb, and 93 controls the depth of Chorus.

A Part for Drums

Part 10 is for playing drums. In the drum part, you use the tones of a drum set. Drum sets are not like ordinary tones in that a different sound is assigned to each key. That is, no matter what key you press in a violin tone, you get a violin sound; it may be a different pitch but it's still a violin sound. However, each key in a drum set tone plays a different instrumental sound: kick, snare, hihat, etc. Since percussion instruments don't generally carry the melody and so have little variation in pitch, we can handle them all on just one channel.

Usual parts

- Select from the 16,384 (128 x 128) different tones.
- Every key sounds the same tone.

Drum part

- Select from the 128 different drum sets.
- A different sound is assigned to each key.

Changing Between Drum Sets

The GS Format has been designed to allow changing between 128 different drum sets for playing drum (actually, there are no modules yet that have 128 different drum sets). Drum sets can be changed using program change numbers.

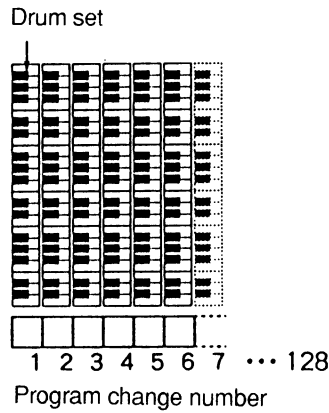

In the GS Format, drum sets are ranked by Program Change numbers roughly the same way as in tone maps. In addition, the kind of sound assigned to a particular key has also been standardized. With the sounds arranged this way, a song will play back pretty much the same every time, no matter what GS sound source you're using.

6

Parts and Voices

Number of Notes You Can Play at Once

There are 24 "oscillators" (sound generating devices) in the SCC-1, each of which can produce one "voice". However, since there are tones that use two of these voices, the actual number of available notes is going to be less than 24. There is no restriction on how many of these voices you can use to play any given part. The total is determined by adding up the number of voices used by all parts, so one part could be assigned all 24 voices. Check with the Tone Table (P.22) or the Drum Set Table (P.27) to find out how many voices are used by each tone.

What Happens When You Try To Play Too Many Notes

The following two special features built into your SCC-1 can keep the melody line from being interrupted if you try to use more than 24 voices at any one time.

● Give The Most Important parts a Higher Priority ... Part Sounding Priority

If you try to play something that exceeds the 24-voice limit, the SCC-1 gives the new notes priority and "steals" voices from notes that are already sounding. There are taken from the lowest priority parts according to the Part Sounding Priority scheme. These Part Sounding Priority ranking follow the GS format. So when writing a song, give some thought to what the most important parts are, and then rank them according to the Part Sounding Priority scheme.

Part Priority ranking	Part No.
1	10(Drum Set)
2	1
3	2
4	3
5	4
6	5
7	6
8	7
9	8
10	9
11	11
12	12
13	13
14	14
15	15
16	16

● **Make Sure that the Most Important Parts Will Have a Voice ... Voice Reserve**

Voice Reserve is the capability of assigning a guaranteed minimum number of voices for a given part, just in case the 24-voice limit is exceeded at some point. For example, Part 10 is set to an Voice Reserve of 6, which means that if all parts are trying to use more than 24 voices at once, part 10 is assured of getting at least 6 of them.

Voice Reserve ensures this minimum regardless of how Part Priority is set. The Voice Reserve number for each part is as follows, so you can see again why it's important to put the most important parts in channels 1-10.

Part 1 - 9	2
Part 10 (Drum Part)	6
Part 11-16	0

7 Appendices

Changing Interrupt Levels and I/O Addresses

When peripheral devices are connected to the computer, you can occasionally run into the problem of conflicting interrupt levels and I/O address with the SCC-1 and your software. This can lead to malfunctions. When this kind of thing happens, you'll have to change the interrupt level and I/O address of the SCC-1 to eliminate the conflict.

Don't forget to also change the interrupt level and I/O address on your software after changing it on the SCC-1.

● Changing I/O Address

Carefully flip the dipswitches to match the diagrams to change I/O address. Use a ballpoint pen or tiny screwdriver, rather than something breakable like a pencil lead.

SW2 :

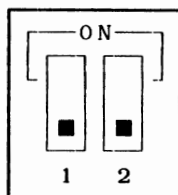

Data Port:330H
Command Port:330H
Status Port:331H

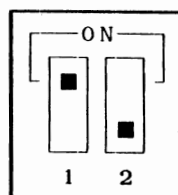

Data Port:332H
Command Port:332H
Status Port:333H

Factory Setting

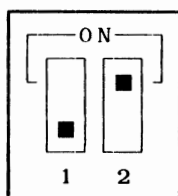

Data Port:334H
Command Port:334H
Status Port:335H

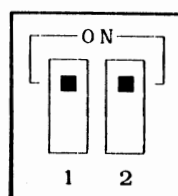

Data Port:336H
Command Port:336H
Status Port:337H

● Changing the Interrupt Level

To change the Interrupt Level, remove the plastic hood in the jumper box with tweezers or a chip puller. Move it to the pair of pins you want for the new IRQ, fit the jumper over the pins and push down.

SW2 :

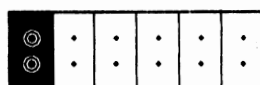

IRQ 2 3 4 5 6 7
↑

Factory Setting

Interrupt Line:IRQ2

Troubleshooting

If things don't work as expected, try troubleshooting in the following order.

If that doesn't fix the problem, contact the dealer you bought the card from or your nearest Roland Service Center.

● No Sound

- Amp (stereo, cassette player, etc.) turned on?
 - Are you plugged in to the correct amp inputs?
 - Is the amp volume all the way down?
 - Is the volume turned down in the software?
Is the volume set to 0 in the software?
- If there is a volume setting in the performance data, reset it.

● Tones Sound Funny

- Have you changed the MIDI cable connection?
If you pull out the MIDI plug in the middle of a song, it may start to play the wrong tones when reinserted.

About MIDI

MIDI stands for Musical Instrument Digital Interface, a world-wide standard for exchanging performance data among computers and electronic musical instruments. An instrument conforming to the MIDI standard, no matter what kind or who made it, can send and receive performance data. This MIDI data is not music itself, but rather a way of handling a variety of digitally-encoded messages telling the instrument what to do.

● MIDI Data Exchange

MIDI data exchange is not that difficult to understand.

◆ MIDI Connections

MIDI data exchange is achieved through three connectors. MIDI cables are used to connect these connectors in whatever arrangement you need for a particular job.

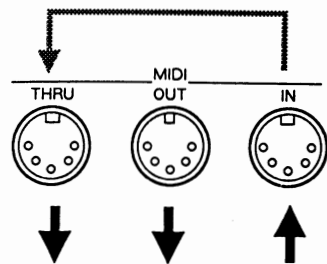

MIDI IN: MIDI data is received from other devices.

MIDI OUT: Data is sent to other devices.

MIDI THRU: The data sent to MIDI IN is sent back out, unchanged.

- * You can use the MIDI THRU connector to “daisy chain” several MIDI devices together so that they all receive the same MIDI data stream. However, four or five devices connected this way is about the limit. Time delays and signal degradation increase with the addition of more devices, causing “glitches” and data transmission errors.

◆ MIDI Channels

Data for a number of different MIDI devices can be sent over the same MIDI cable. This is the result of the MIDI Channel concept.

A MIDI Channel is a lot like a TV Channel. As you switch channels, you see completely different programs; but this information is only received when the channel on your TV is set to the same channel that the TV station is broadcasting on.

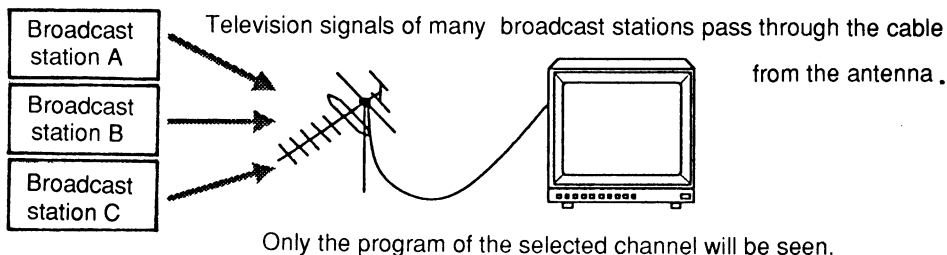

MIDI has channels numbered 1-16, and MIDI data on any one channel is sent to all instruments set to receive on that same channel. For example, playing a keyboard with the MIDI channel set like the following will play only sound source B.

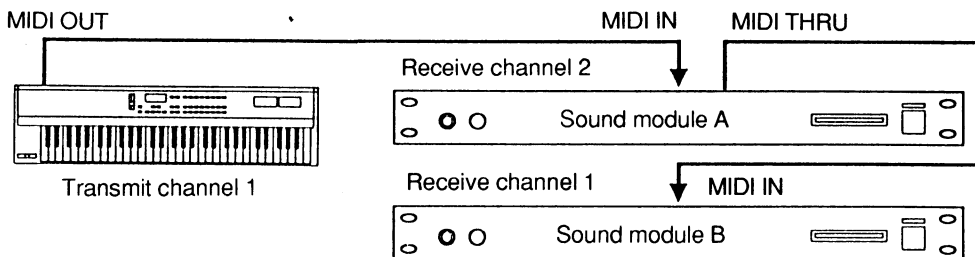

● The SCC-1 Handles Different Kinds of MIDI Data

Each part on the SCC-1 can receive the following kinds of MIDI data.

◆ Note Message

Note message is used to transmit message from performances on keyboards or other MIDI-capable instruments. Note message contains the following information:

Note Number: Indicates which note on the keyboard has been played.

Note on: Indicates that the key has been played.

Note off: Indicates that the key has been released.

Velocity: Indicates the force (speed) with which the key is played.

Note Numbers use integers from 0 to 127 to indicate the position of a key, with Middle C (C4) being number 60. In drum parts, a note number has been assigned to each of the various percussion and sound effects.

◆ Pitch Bend Message

This is used to transmit message about the operation of the pitch bend wheel (or lever) usually found on synthesizers. Pitch benders can continuously change the pitch of a note over a wide range.

◆ **Aftertouch Message**

This is used to transmit message about aftertouch, that is, pressure on a key after it has been played (aftertouch add additional expressiveness to a performance). There are two kinds: channel aftertouch and polyphonic aftertouch.

Channel aftertouch affects all tones on the same MIDI channel, no matter what key is pressed. In polyphonic aftertouch though, only the key (note) being played is affected.

◆ **Program Change Message**

This allows you to transmit information about changing tones. On the SCC-1, you can specify a new tone using a combination of Control Change number 0/32 and a Program Change number.

◆ **Control Change Message**

This transmits message about vibrato, hold, volume, pan, and other features that allow more expressiveness to be added to performances. Each kind of expression is assigned a control number between 0 and 127. However, not all MIDI devices are capable of vibrato, or panning, etc.; so it depends on the device whether or not it can respond to these control numbers.

On the SCC-1, Control Change number 0/32 is used to change between tone variations.

Initial Settings

Sound source settings when the computer is first turned on.

(Changes in settings are saved until you turn the computer off.)

<Part Settings>

Part	1-9, 11-16	10 (Drum Part)
MIDI receiving channel	Same No. as part	
Tone(Tone Number)	Piano 1(# 1)	Standard Set
Volume Level	100	100
Pan	Center	Center
Reverb	40	40
Chorus	0	0
Key Shift	0	0
Bend Sens.	2	2

<Overall Part Settings>

Volume	127
Pan	Center
Reverb	64
Chorus	64
Key Shift	0

Tone Table

	PC #	CCO #	Tone name	V	Recommended sound range	
Piano	1	0	Piano 1	1	A0 (21) — C8 (108)	
	2	0	Piano 2	1		
	3	0	Piano 3	1		
	4	0	Honky-tonk	2		
	5	0	E. Piano 1	1	E1 (28) — G7 (103)	
		8	Detuned EP 1	2		
		6	0	E. Piano 2		1
			8	Detuned EP 2		2
7	0	Harpichord	1	F2 (41) — F6 (89)		
	8	Coupled Hps.	2			
8	0	Clav.	1	C2 (36) — C7 (96)		
Chromatic Percussion	9	0	Celesta	1	C4 (60) — C8 (108)	
	10	0	Glockenspiel	1	C5 (72) — C8 (108)	
	11	0	Music Box	1	C4 (60) — C6 (84)	
	12	0	Vibraphone	1	F3 (53) — F6 (89)	
	13	0	Marimba	1	C3 (48) — C6 (84)	
	14	0	Xylophone	1	F4 (65) — C7 (96)	
	15	0	Tubular-bell	1	C4 (60) — F5 (77)	
		8	Church Bell	1		
16	0	Santur	1	C4 (60) — C6 (84)		
Organ	17	0	Organ 1	1	C2 (36) — C7 (96)	
		8	Detuned Or. 1	2		
	18	0	Organ 2	1		
		8	Detuned Or. 2	2		
	19	0	Organ 3	2	A0 (21) — C8 (108)	
	20	0	Church Org. 1	1		
		8	Church Org. 2	2		
	21	0	Reed Organ	1		C2 (36) — C7 (96)
	22	0	Accordion Fr	2	F3 (53) — F6 (89)	
		8	Accordion It	2		
23	0	Harmonica	1	C4 (60) — C6 (84)		
24	0	Bandneon	2	F3 (53) — F6 (89)		

	PC #	CCO #	Tone name	V	Recommended sound range
Guitar	25	0	Nylon-str. Gt.	1	E2 (40) — C6 (84)
		8	Ukulele	1	A3 (57) — B5 (83)
	26	0	Steel-str. Gt.	1	E2 (40) — C6 (84)
		8	12-str. Gt.	2	
		16	Mandolin	1	
	27	0	Jazz Gt.	1	E2 (40) — D6 (86)
		8	Hawaiian Gt.	1	
	28	0	Clean Gt.	1	
		8	Chorus Gt.	2	
	29	0	Muted Gt.	1	
		8	Funk Gt.	1	
	30	0	Overdrive Gt.	1	
31	0	Distortion Gt.	1		
	8	Feedback Gt.	2		
32	0	Gt. Harmonics	1		
	8	Gt. Feedback	1		
Bass	33	0	Acoustic Bs.	1	E1 (28) — G3 (55)
	34	0	Fingered Bs.	1	
	35	0	Picked Bs.	1	
	36	0	Fretless Bs.	1	
	37	0	Slap Bass 1	1	
	38	0	Slap Bass 2	1	
	39	0	Synth Bass 1	1	
		8	Synth Bass 3	1	
40	0	Synth Bass 2	2		
	8	Synth Bass 4	2		

PC # : Program number

CCO # : Value of control number 0
(GS bank select number)

V : Number of voices

Recommended sound range : The recommended sound range does not indicate the limit of sound production. The actual playable range extends beyond the recommended sound range.

	PC #	CC0 #	Tone name	V	Recommended sound range
Strings/orchestra	41	0	Violin	1	G3 (55) — C7 (96)
	42	0	Viola	1	G3 (48) — C6 (84)
	43	0	Cello	1	C2 (36) — C5 (72)
	44	0	Contrabass	1	E1 (28) — G3 (55)
	45	0	Tremolo Str	1	E1 (28) — C7 (96)
	46	0	PizzicatoStr	1	
	47	0	Harp	1	B0 (23) — G7 (103)
	48	0	Timpani	1	C2 (36) — A3 (57)
Ensemble	49	0	Strings	1	E1 (28) — C7 (96)
		8	Orchestra	2	C1 (24) — C7 (96)
	50	0	Slow Strings	1	E1 (28) — C7 (96)
	51	0	Syn. Strings1	1	C2 (36) — C7 (96)
		8	Syn. Strings3	2	C1 (24) — C7 (96)
	52	0	Syn. Strings2	2	C2 (36) — C7 (96)
	53	0	Choir Aahs	1	C3 (48) — G5 (79)
	54	0	Voice Oohs	1	
	55	0	SynVox	1	C3 (48) — C6 (84)
	56	0	OrchestraHit	2	C3 (48) — C5 (72)
Brass	57	0	Trumpet	1	A # 3 (58) — A # 6 (94)
	58	0	Trombone	1	A # 1 (34) — D # 5 (75)
	59	0	Tuba	1	F1 (29) — G3 (55)
	60	0	MutedTrumpet	1	A # 3 (58) — A # 5 (82)
	61	0	French Horn	2	F2 (41) — F5 (77)
		0	Brass 1	1	C2 (36) — C7 (96)
	8	Brass 2	2		
	63	0	Synth Brass1	2	
		8	Synth Brass3	2	
	64	0	Synth Brass2	2	
8		Synth Brass4	1		

PC # : Program number
 CC0 # : Value of control number 0
 (GS bank select number)
 V : Number of voices

Recommended sound range : The recommended sound range does not indicate the limit of sound production. The actual playable range extends beyond the recommended sound range.

	PC #	CC0 #	Tone name	V	Recommended sound range	
Reed	65	0	Soprano Sax	1	F # 3 (54) — D # 6 (87)	
	66	0	Alto Sax	1	C # 3 (49) — G # 5 (80)	
	67	0	Tenor Sax	1	F # 2 (42) — D # 5 (75)	
	68	0	Baritone Sax	1	C # 2 (37) — G # 4 (68)	
	69	0	Oboe	1	A # 3 (58) — G6 (91)	
	70	0	English Horn	1	E3 (52) — A5 (81)	
	71	0	Bassoon	1	A # 1 (34) — C5 (72)	
	72	0	Clarinet	1	D3 (50) — G6 (91)	
	Pipe	73	0	Piccolo	1	D5 (74) — C8 (108)
		74	0	Flute	1	C4 (60) — C7 (96)
		75	0	Recorder	1	
		76	0	Pan Flute	1	
77		0	Bottle Blow	2		
78		0	Shakuhachi	2		
79		0	Whistle	1		
80		0	Ocarina	1		
Synth lead		81	0	Square Wave	2	
			8	Sine Wave	1	
	82	0	Saw Wave	2		
	83	0	Syn. Calliope	2		
	84	0	Chiffer Lead	2		
	85	0	Charang	2		
	86	0	Solo Vox	2		
	87	0	5th Saw Wave	2		
88	0	Bass & Lead	2			
Synth pad etc.	89	0	Fantasia	2		
	90	0	Warm Pad	1		
	91	0	Polysynth	2		
	92	0	Space Voice	1		
	93	0	Bowed Glass	2		
	94	0	Metal Pad	2		
	95	0	Halo Pad	2		
	96	0	Sweep Pad	1		

	PC #	CCO #	Tone name	V
Synth SFX	97	0	Ice Rain	2
	98	0	Soundtrack	2
	99	0	Crystal	2
	100	0	Atmosphere	2
	101	0	Brightness	2
	102	0	Goblin	2
	103	0	Echo Drops	1
	104	0	Star Theme	2
Ethnic	105	0	Sitar	1
	106	0	Banjo	1
	107	0	Shamisen	1
	108	0	Koto	1
		8	Taisho Koto	2
	109	0	Kalimba	1
	110	0	Bag Pipe	1
111	0	Fiddle	1	
112	0	Shannai	1	
Percussive	113	0	Tinkle Bell	1
	114	0	Agogo	1
	115	0	Steel Drums	1
	116	0	Woodblock	* 1
		8	Castanets	* 1
	117	0	Taiko	* 1
		8	Concert BD	* 1
	118	0	Melo Tom 1	* 1
		8	Melo Tom 2	* 1
	119	0	Synth Drum	* 1
		8	808 Tom	* 1
120	0	Reverse Cym.	* 2	

PC # : Program number

CCO # : Value of control number 0
(GS bank select number)

V : Number of voices

* : All tones marked by an * have an unreliable pitch. Please use a key around C4 (Key # 60).
The unmarked tones use temperament and pitch of A4 (Key # 59) is 440Hz.

	PC #	CCO #	Tone name	V
121	0		Gt. FretNoise	* 1
	1		Gt. Cut Noise	* 1
	2		String Slap	* 1
122	0		Breath Noise	2
	1		Fl. Key Click	* 1
123	0		Seashore	* 1
	1		Rain	* 2
	2		Thunder	* 1
	3		Wind	* 1
	4		Stream	* 2
124	5		Bubble	* 2
	0		Bird	* 2
	1		Dog	* 1
125	2		Horse-Gallop	* 1
	0		Telephone 1	* 1
	1		Telephone 2	* 1
	2		Door Creaking	* 1
	3		Door	* 1
126	4		Scratch	* 1
	5		Windchime	* 2
	0		Helicopter	* 1
	1		Car-Engine	* 1
	2		Car-Stop	* 1
	3		Car-Pass	* 1
	4		Car-Crash	* 2
	5		Siren	* 1
	6		Train	* 1
7		Jetplane	* 2	
127	8		Starship	* 2
	9		Burst Noise	* 2
	0		Applause	* 2
	1		Laughing	* 1
	2		Screaming	* 1
128	3		Punch	* 1
	4		Heart Beat	* 1
	5		Footsteps	* 1
128	0		Gun Shot	* 1
	1		Machine Gun	* 1
	2		Lasergun	* 1
	3		Explosion	* 2

● CC0 # : 126

PC #	Tone name	V
1	A. Piano 1	2
2	A. Piano 2	2
3	A. Piano 3	2
4	A. Piano 4	2
5	A. Piano 5	1
6	A. Piano 7	1
7	A. Piano 9	1
8	E. Piano 1	2
9	E. Piano 3	2
10	E. Piano 5	2
11	A. Guitar 1	1
12	A. Guitar 3	2
13	A. Guitar 4	2
14	E. Guitar 1	1
15	E. Guitar 2	1
16	Slap 3	1
17	Slap 4	2
18	Slap 5	1
19	Slap 6	1
20	Slap 9	1
21	Slap 10	2
22	Slap 11	1
23	Slap 12	1
24	Fingered 1	1
25	Fingered 2	2
26	Picked 1	1
27	Picked 2	2
28	Fretless 1	1
29	AC Bass 1	2
30	Choir 1	1
31	Choir 2	1
32	Choir 3	2

PC #	Tone name	V
33	Choir 4	2
34	Strings 1	1
35	Strings 2	1
36	Strings 3	2
37	Strings 4	2
38	E. Organ 2	2
39	E. Organ 4	2
40	E. Organ 6	2
41	E. Organ 8	2
42	E. Organ 9	2
43	E. Organ 10	2
44	E. Organ 11	2
45	E. Organ 12	2
46	E. Organ 13	2
47	Soft TP 1	1
48	Soft TP 3	1
49	TP/TRB 1	1
50	TP/TRB 2	1
51	TP/TRB 3	1
52	TP/TRB 4	1
53	TP/TRB 5	2
54	TP/TRB 6	2
55	Sax 1	1
56	Sax 2	1
57	Sax 3	1
58	Sax 5	2
59	Brass 1	1
60	Brass 2	1
61	Brass 3	2
62	Brass 4	2
63	Brass 5	2
64	Orche Hit	1

CC0 # : Value of control number 0
(GS bank select number)

PC # : Program number

V : Number of voices

※ 126 of control number 0 is set to the same sound arrangement of the CM-32P (Roland PCM Sound Module). But the setting of the pitch bend range, modulation depth, etc., are different from that of CM-32P. Pan directions are reversed from an actual CM-32P, so to rectify this, reverse the L/R connections of the Audio Output jacks.

※ If exclusive messages of the CM-32P are received by the SCC-1, the settings of the latter will not be changed.

● CC0 # : 127

PC#	Tone name	V	PC#	Tone name	V	PC#	Tone name	V	PC#	Tone name	V
1	Acou Piano 1	1	33	Fantasy	2	65	Acou Bass 1	1	97	Brs Sect 2	2
2	Acou Piano 2	1	34	Harmo Pan	2	66	Acou Bass 2	1	98	Vibe 1	1
3	Acou Piano 3	1	35	Chorale	1	67	Elec Bass 1	1	99	Vibe 2	1
4	Elec Piano 1	1	36	Glasses	2	68	Elec Bass 2	1	100	Syn Mallet	1
5	Elec Piano 2	1	37	Soundtrack	2	69	Slap Bass 1	1	101	Windbell	2
6	Elec Piano 3	1	38	Atmosphere	2	70	Slap Bass 2	1	102	Glock	1
7	Elec Piano 4	1	39	Warm Bell	2	71	Fretless 1	1	103	Tube Bell	1
8	Honkytonk	2	40	Funny Vox	1	72	Fretless 2	1	104	Xylophone	1
9	Elec Org 1	1	41	Echo Bell	2	73	Flute 1	1	105	Marimba	1
10	Elec Org 2	2	42	Ice Rain	2	74	Flute 2	1	106	Koto	1
11	Elec Org 3	1	43	Oboe 2001	2	75	Piccolo 1	1	107	Sho	2
12	Elec Org 4	1	44	Echo Pan	2	76	Piccolo 2	2	108	Shakuhachi	2
13	Pipe Org 1	2	45	Doctor Solo	2	77	Recorder	1	109	Whistle 1	2
14	Pipe Org 2	2	46	Schooldaze	1	78	Pan Pipes	1	110	Whistle 2	1
15	Pipe Org 3	2	47	Bellsinger	1	79	Sax 1	1	111	Bottleblow	2
16	Accordion	2	48	Square Wave	2	80	Sax 2	1	112	Breathpipe	1
17	Harpsi 1	1	49	Str Sect 1	1	81	Sax 3	1	113	Timpani	1
18	Harpsi 2	2	50	Str Sect 2	1	82	Sax 4	1	114	Melodic Tom	1
19	Harpsi 3	1	51	Str Sect 3	1	83	Clarinet 1	1	115	Deep Snare	1
20	Clavi 1	1	52	Pizzicato	1	84	Clarinet 2	1	116	Elec Perc 1	1
21	Clavi 2	1	53	Violin 1	1	85	Oboe	1	117	Elec Perc 2	1
22	Clavi 3	1	54	Violin 2	1	86	Engl Horn	1	118	Taiko	1
23	Celesta 1	1	55	Cello 1	1	87	Bassoon	1	119	Taiko Rim	1
24	Celesta 2	1	56	Cello 2	1	88	Harmonica	1	120	Cymbal	1
25	Syn Brass 1	2	57	Contrabass	1	89	Trumpet 1	1	121	Castanets	1
26	Syn Brass 2	2	58	Harp 1	1	90	Trumpet 2	1	122	Triangle	1
27	Syn Brass 3	2	59	Harp 2	1	91	Trombone 1	2	123	Orche Hit	1
28	Syn Brass 4	2	60	Guitar 1	1	92	Trombone 2	2	124	Telephone	1
29	Syn Bass 1	1	61	Guitar 2	1	93	Fr Horn 1	2	125	Bird Tweet	1
30	Syn Bass 2	2	62	Elec Gtr 1	1	94	Fr Horn 2	2	126	One Note Jam	1
31	Syn Bass 3	2	63	Elec Gtr 2	1	95	Tuba	1	127	Water Bells	2
32	Syn Bass 4	1	64	Sitar	2	96	Brs Sect 1	1	128	Jungle Tune	2

CC0 # : Value of control number 0
(GS bank select number)

PC # : Program number

V : Number of voices

※ 127 of control number 0 is set to the same sound arrangement of the MT-32 (Roland Multi Timbre Sound Module). But the setting of the pitch bend range, modulation depth, etc., are different from that of MT-32. Pan directions are reversed from an actual MT-32, so to rectify this, reverse the L/R connections of the Audio Output jacks.

※ If exclusive messages of the MT-32 are received by the SCC-1, the settings of the latter will not be changed.

Drum Set Table

Note number	PC#1:STANDARD Set PC#33:JAZZ Set	PC#9:ROOM Set	PC#17:POWER Set	PC#25: ELECTRONIC Set	PC#26:TR-808 Set	PC#41: BRUSH Set	PC#49:ORCHESTRA Set
27	High O						Closed Hi-Hat [EXC1]
28	Slap						Pedal Hi-Hat [EXC1]
29	Scratch Push						Open Hi-Hat [EXC1]
30	Scratch Pull						Ride Cymbal
31	Sticks						
32	Square Click						
33	Metronome Click						
34	Metronome Bell						
35	Kick Drum 2						Concert BD 2
36	Kick Drum 1		MONDO Kick	Elec BD	808 Bass Drum		Concert BD 1
37	Side Stick				808 Rim Shot		
38	Snare Drum 1		Gated SD	Elec SD	808 Snare Drum	Brush Tap	Concert SD
39	Hand Clap					Brush Slap	Castanets
40	Snare Drum 2			Gated SD		Brush Swirl	Concert SD
41	Low Tom 2	Room Low Tom 2	Room Low Tom 2	Elec Low Tom 2	808 Low Tom 2		Timpani F
42	Closed Hi - hat [EXC1]				808 CHH [EXC1]		Timpani F#
43	Low Tom 1	Room Low Tom 1	Room Low Tom 1	Elec Low Tom 1	808 Low Tom 1		Timpani G
44	Pedal Hi - hat [EXC1]				808 CHH [EXC1]		Timpani G#
45	Mid Tom 2	Room Mid Tom 2	Room Mid Tom 2	Elec Mid Tom 2	808 Mid Tom 2		Timpani A
46	Open Hi - hat [EXC1]				808 OHH [EXC1]		Timpani A#
47	Mid Tom 1	Room Mid Tom 1	Room Mid Tom 1	Elec Mid Tom 1	808 Mid Tom 1		Timpani B
48	High Tom 2	Room Hi Tom 2	Room Hi Tom 2	Elec Hi Tom 2	808 Hi Tom 2		Timpani c
49	Crash Cymbal 1				808 Cymbal		Timpani c#
50	High Tom 1	Room Hi Tom 1	Room Hi Tom 1	Elec Hi Tom 1	808 Hi Tom 1		Timpani d
51	Ride Cymbal 1						Timpani d#
52	Chinese Cymbal			Reverse Cymbal ★			Timpani e
53	Ride Bell						Timpani f
54	Tambourine						
55	Splash Cymbal						
56	Cowbell				808 Cowbell		
57	Crash Cymbal 2						Concert Cymbal 2
58	Vibra - slap						
59	Ride Cymbal 2						Concert Cymbal 1
60	High Bongo						
61	Low Bongo						
62	Mute High Conga				808 High Conga		
63	Open High Conga				808 Mid Conga		
64	Low Conga				808 Low Conga		
65	High Timbale						
66	Low Timbale						
67	High Agogo						
68	Low Agogo						
69	Cabasa						
70	Maracas				808 Maracas		
71	Short Hi Whistle [EXC2]						
72	Long Low Whistle [EXC2]						
73	Short Guiro [EXC3]						
74	Long Guiro [EXC3]						
75	Claves				808 Claves		
76	High Wood Block						
77	Low Wood Block						
78	Mute Cuica [EXC4]						
79	Open Cuica [EXC4]						
80	Mute Triangle [EXC5]						
81	Open Triangle [EXC5]						
82	Shaker						
83	Jingle Bell						
84	Belltree						
85	Castanets						
86	Mute Surdo [EXC6]						
87	Open Surdo [EXC6]						
88							Applause ★

PC # : Program number

★ : Tones which are created by using two voices.
(All other tones are created by one voice.)

Blank : Same as the percussion sound of "STANDARD"

----- : No sound

[EXC] : Percussion sound of the same number will not be heard at the same time.

● SFX set (Program number 57)

● CM-64/32L set (Program number 128)

Note number	PC#57:SFX Set
40	39 High O
	Slap
41	Scratch Push
	Scratch Pull
43	42 Sticks
	Square Click
45	44 Metronome Click
	Metronome Bell
47	46 Guitar sliding finger
	Guitar cutting noise (down)
48	49 Guitar cutting noise (up)
50	String slap of double bass
52	51 Fl. Key Click
	Laughing
53	Screaming
	54 Punch
55	Heart Beat
	56 Footsteps1
57	Footsteps2
	58 Applause ★
59	Door Creaking
	Door
60	61 Scratch
	Windchime ★
62	63 Car-Engine
	Car-Stop
64	Car-Pass
	66 Car-Crash ★
67	Siren
	68 Train
69	Jetplane ★
	70 Helicopter
71	Starship ★
	Gun Shot
72	73 Machine Gun
	Lasergun
74	75 Explosion ★
	Dog
77	Horse-Gallop
	78 Birds ★
79	Rain ★
	80 Thunder
81	Wind
	82 Seashore
83	Stream ★
84	Bubble ★

★ : Tones which are created by using two voices.

(All other tones are created by one voice.)

----- : No sound

[EXC] : Percussion sounds of the same number cannot be heard at the same time.

※ The CM-64/32L set is the MT-32 drum set with SFX sounds added to it.

Note number	PC#128:CM-64/32L Set
35	34 -----
	Acoustic Bass Drum
36	Acoustic Bass Drum
	37 Rim Shot
38	Acoustic Snare Drum
	39 Hand Clap
40	Electronic Snare Drum
	Acoustic Low Tom
41	42 Closed High Hat [EXC1]
	Acoustic Low Tom
43	44 Open High Hat 2
	Acoustic Middle Tom
45	46 Open High Hat 1 [EXC1]
	Acoustic Middle Tom
47	Acoustic High Tom
	49 Crash Cymbal
48	Acoustic High Tom
	50 Acoustic High Tom
50	51 Ride Cymbal

52	-----

53	54 Tambourine

55	-----
	56 Cowbell
57	-----

58	-----

59	-----
	High Bongo
60	61 Low Bongo
	Mute High Conga
62	63 High Conga
	Low Conga
64	High Timbale
	66 Low Timbale
65	High Agogo
	68 Low Agogo
67	Cabasa
	70 Maracas
69	Short Whistle
	Long Whistle
71	73 Ouljada

72	75 Claves
	Laughing
76	Screaming
	78 Punch
77	Heartbeat
	80 Footsteps 1
79	Footsteps 2
	82 Applause ★
81	Creaking
	Door
83	85 Scratch
	Windchime ★
84	87 Engine
	Car-Stop
88	Car-Pass
	90 Crash
89	Siren
	92 Train
91	Jet
	94 Helicopter
93	Starship ★
	Pistol
95	97 Machine Gun
	Lasergun
96	99 Explosion ★
	Dog
98	Horse-Gallop
	102 Birds ★
100	Rain ★
	104 Thunder
101	Wind
	106 Waves
105	Stream ★
	107 Bubble ★
107	-----

108	-----

Block Diagram

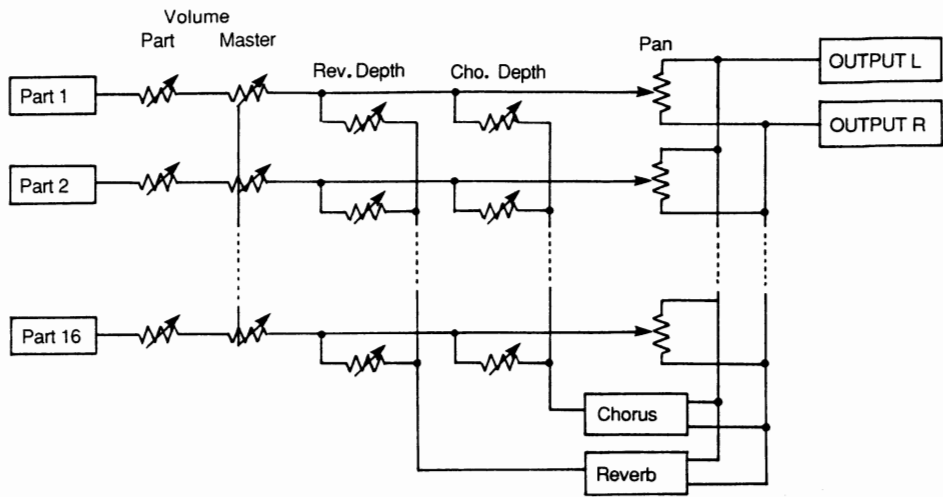

Roland Exclusive Messages

1. Data Format for Exclusive Messages

Roland's MIDI implementation uses the following data format for all exclusive messages (type IV):

Byte	Description
F0H	Exclusive status
41H	Manufacturer ID (Roland)
DEV	Device ID
MDL	Model ID
CMD	Command ID
[BODY]	Main data
F7H	End of exclusive

MIDI status : F0H, F7H

An exclusive message must be flanked by a pair of status codes, starting with a Manufacturer-ID immediately after F0H (MIDI version 1.0).

Manufacturer-ID : 41H

The Manufacturer-ID identifies the manufacturer of a MIDI instrument that triggers an exclusive message. Value 41H represents Roland's Manufacturer-ID.

Device-ID : DEV

The Device-ID contains a unique value that identifies the individual device in the multiple implementation of MIDI instruments. It is usually set to 00H - 0FH, a value smaller by one than that of a basic channel, but value 00H - 1FH may be used for a device with multiple basic channels.

Model-ID : MDL

The Model-ID contains a value that uniquely identifies one model from another. Different models, however, may share an identical Model-ID if they handle similar data.

The Model-ID format may contain 00H in one or more places to provide an extended data field. The following are examples of valid Model-IDs, each representing a unique model:

01H
02H
03H
00H, 01H
00H, 02H
00H, 00H, 01H

Command-ID : CMD

The Command-ID indicates the function of an exclusive message. The Command-ID format may contain 00H in one or more places to provide an extended data field. The following are examples of valid Command-IDs, each representing a unique function:

01H
02H
03H
00H, 01H
00H, 02H
00H, 00H, 01H

Main data : BODY

This field contains a message to be exchanged across an interface. The exact data size and contents will vary with the Model-ID and Command-ID.

2. Address-mapped Data Transfer

Address mapping is a technique for transferring messages conforming to the data format given in Section 1. It assigns a series of memory-resident records-waveform and tone data, switch status, and parameters, for example—to specific locations in a machine-dependent address space, thereby allowing access to data residing at the address a message specifies.

Address-mapped data transfer is therefore independent of models and data categories. This technique allows use of two different transfer procedures: one-way transfer and handshake transfer.

One-way transfer procedure (See Section 3 for details.)

This procedure is suited for the transfer of a small amount of data. It sends out an exclusive message completely independent of a receiving device status.

Connection Diagram

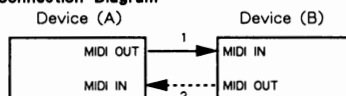

Connection at point 2 is essential for "Request data" procedures. (See Section 3.)

Handshake transfer procedure (This device does not cover this procedure)

This procedure initiates a predetermined transfer sequence (handshaking) across the interface before data transfer takes place. Handshaking ensures that reliability and transfer speed are high enough to handle a large amount of data.

Connection Diagram

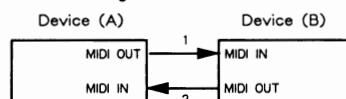

Connection at points 1 and 2 is essential.

Notes on the above two procedures

- * There are separate Command-IDs for different transfer procedures.
- * Devices A and B cannot exchange data unless they use the same transfer procedure, share identical Device-ID and Model ID, and are ready for communication.

3. One-way Transfer Procedure

This procedure sends out data all the way until it stops and is used when the messages are so short that answerbacks need not be checked.

For long messages, however, the receiving device must acquire each message in time with the transfer sequence, which inserts intervals of at least 20 milliseconds in between.

Types of Messages

Message	Command ID
Request data 1	RQ1 (11H)
Data set 1	DT1 (12H)

Request data # 1 : RQ1 (11H)

This message is sent out when there is a need to acquire data from a device at the other end of the interface. It contains data for the address and size that specify designation and length, respectively, of data required. On receiving an RQ1 message, the remote device checks its memory for the data address and size that satisfy the request.

If it finds them and is ready for communication, the device will transmit a "Data set 1 (DT1)" message, which contains the requested data. Otherwise, the device will send out nothing.

Byte	Description
FOH	Exclusive status
41H	Manufacturer ID (Roland)
DEV	Device ID
MDL	Model ID
11H	Command ID
aaH	Address MSB
⋮	⋮
	LSB
ssH	Size MSB
⋮	⋮
	LSB
sum	Check sum
F7H	End of exclusive

- * The size of the requested data does not indicate the number of bytes that will make up a DT1 message, but represents the address fields where the requested data resides.
- * Some models are subject to limitations in data format used for a single transaction. Requested data, for example, may have a limit in length or must be divided into predetermined address fields before it is exchanged across the interface.
- * The same number of bytes comprises address and size data, which, however, vary with the Model-ID.
- * The error checking process uses a checksum that provides a bit pattern where the least significant 7 bits are zero when values for an address, size, and that checksum are summed.

Data set 1 : DT1 (12H)

This message corresponds to the actual data transfer process. Because every byte in the data is assigned a unique address, a DT1 message can convey the starting address of one or more data as well as a series of data formatted in an address-dependent order.

The MIDI standards inhibit non-real time messages from interrupting an exclusive one. This fact is inconvenient for the devices that support a "soft-through" mechanism. To maintain compatibility with such devices, Roland has limited the DT1 to 256 bytes so that an excessively long message is sent out in separate segments.

Byte	Description
FOH	Exclusive
41H	Manufacturer ID (Roland)
DEV	Device ID
MDL	Model ID
12H	Command ID
aaH	Address MSB
⋮	⋮
	LSB
ddH	Data
⋮	⋮
sum	Check sum
F7H	End of exclusive

- * A DT1 message is capable of providing only the valid data among those specified by an RQ1 message.
- * Some models are subject to limitations in data format used for a single transaction. Requested data, for example, may have a limit in length or must be divided into predetermined address fields before it is exchanged across the interface.
- * The number of bytes comprising address data varies from one Model-ID to another.
- * The error checking process uses a checksum that provides a bit pattern where the least significant 7 bits are zero when values for an address, size, and that checksum are summed.

Example of Message Transactions

- Device A sending data to Device B
Transfer of a DT1 message is all that takes place.

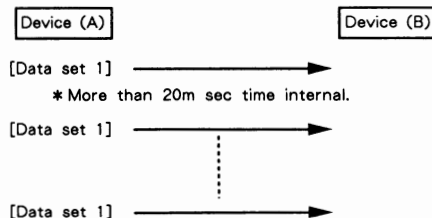

- Device B requesting data from Device A
Device B sends an RQ1 message to Device A. Checking the message, Device A sends a DT1 message back to Device B.

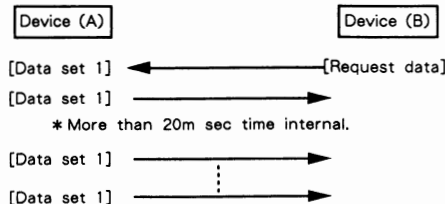

1. RECEIVED DATA**■ CHANNEL VOICE MESSAGE****● NOTE OFF**

<u>status</u>	<u>second</u>	<u>third</u>
8nH	kkH	vvH
9nH	kkH	00H

n = MIDI channel number : 0H - FH (1 - 16)
 kk = note number : 00H - 7FH (0 - 127)
 vv = velocity : 00H - 7FH < ignored >

* These messages are recognized when "RX.NOTE MESSAGE = ON".

* On drums part, these messages are recognized when "RX.NOTE OFF = ON" at each tone.

● NOTE ON

<u>status</u>	<u>second</u>	<u>third</u>
9nH	kkH	vvH

n = MIDI channel number : 0H - FH (1 - 16)
 kk = note number : 00H - 7FH (0 - 127)
 vv = velocity : 01H - 7FH (1 - 127)

* This message is recognized when "RX.NOTE MESSAGE = ON".

* On drums part, this message is recognized when "RX.NOTE ON = ON" at each tone.

● POLYPHONIC KEY PRESSURE

<u>status</u>	<u>second</u>	<u>third</u>
AnH	kkH	vvH

n = MIDI channel number : 0H - FH (1 - 16)
 kk = note number : 00H - 7FH (0 - 127)
 vv = value : 00H - 7FH (0 - 127)

* This message is recognized when "RX.POLY PRESSURE (PAF) = ON" and set on "PAF CONTROLLER FUNCTION".

● CONTROL CHANGE

* These messages are recognized when "RX.CONTROL CHANGE = ON" and set on "CONTROLLER FUNCTION".

* All controll messages without channel mode messages are not recognized when "RX.CONTROL CHANGE = OFF".

○ BANK SELECT

<u>status</u>	<u>second</u>	<u>third</u>
BnH	00H	mmH
BnH	20H	llH

n = MIDI channel number : 0H - FH (1 - 16)
 mm = bank number : 00H - 7FH (0 - 127)
 ll = bank number : 00H (0)

* "Bank select" is suspended until receiving "PROGRAM CHANGE".

○ MODULATION

<u>status</u>	<u>second</u>	<u>third</u>
BnH	01H	vvH

n = MIDI channel number : 0H - FH (1 - 16)
 vv = modulation depth : 00H - 7FH (0 - 127)

* This message is recognized when "RX.MODULATION = ON" and set on "MOD CONTROLLER FUNCTION".

○ PORTAMENTO TIME

<u>status</u>	<u>second</u>	<u>third</u>
BnH	05H	vvH

n = MIDI channel number : 0H - FH (1 - 16)
 vv = portamento time : 00H - 7FH (0 - 127)

○ DATA ENTRY

<u>status</u>	<u>second</u>	<u>third</u>
BnH	06H	mmH
BnH	26H	llH

n = MIDI channel number : 0H - FH (1 - 16)
 mm = value of the parameter specified with RPN and/or NRPN (MSB)

ll = value of the parameter specified with RPN (LSB)

○ VOLUME

<u>status</u>	<u>second</u>	<u>third</u>
BnH	07H	vvH

n = MIDI channel number : 0H - FH (1 - 16)
 vv = volume : 00H - 7FH (0 - 127)

* You can adjust the volume of specified channel (part). The maximum volume is determined by EXPRESSION and MASTER VOLUME message.

* This message is recognized when "RX.VOLUME = ON".

○ PANPOT

<u>status</u>	<u>second</u>	<u>third</u>
BnH	0AH	vvH

n = MIDI channel number : 0H - FH (1 - 16)
 vv = panpot : 00H - 40H - 7FH (1 - 64 - 127)
 < Left - Center - Right >

* Resolution of panpot is approx. 7-bit (127 steps).

* This message is recognized when "RX.PANPOT = ON".

○ EXPRESSION

<u>status</u>	<u>second</u>	<u>third</u>
BnH	0BH	vvH

n = MIDI channel number : 0H - FH (1 - 16)
 vv = expression : 00H - 7FH (0 - 127)

* You can adjust the volume of specified channel (part).

The maximum volume is determined by VOLUME and MASTER VOLUME message.

* This message is recognized when "RX.EXPRESSION = ON".

○ HOLD1

<u>status</u>	<u>second</u>	<u>third</u>
BnH	40H	vvH

n = MIDI channel number : 0H - FH (1 - 16)
 vv = control value : 00H - 3FH (0 - 63) < OFF >
 40H - 7FH (63 - 127) < ON >

* This message is recognized when "RX.HOLD1 = ON".

○PORTAMENTO

status second third
 BnH 41H vvH

n = MIDI channel number :0H - FH (1 - 16)
 vv = control value :00H - 3FH (0 - 63) < OFF >
 40H - 7FH (63 - 127) < ON >

* This message is recognized when "RX.PORTAMENTO = ON".
 * In poly mode, you cannot specify the portamento source pitch.
 If you wish to specify the source pitch, you may use LGC (Legato Control).

○SOSTENUTO

status second third
 BnH 42H vvH

n = MIDI channel number :0H - FH (1 - 16)
 vv = control value :00H - 3FH (0 - 63) < OFF >
 40H - 7FH (63 - 127) < ON >

* This message is recognized when "RX.SOSTENUTE = ON".

○SOFT

status second third
 BnH 43H vvH

n = MIDI channel number :0H - FH (1 - 16)
 vv = control value :00H - 3FH (0 - 63) < OFF >
 40H - 7FH (63 - 127) < ON >

* This message is recognized when "RX.SOFT = ON".

○LGC (Legato Control)

status second third
 BnH 54H kkH

n = MIDI channel number :0H - FH (1 - 16)
 kk = legato source key number :00H - 7FH (0 - 127)

* When a note on is just come after LGC logically, the voice is turned re-tuning on from the pitch of legato source key according to the portamento time (no need to use portamento on/off).
 If a voice turned on before LGC and the key number is equal to the legato source key number of LGC and other note on come after LGC, the pitch of previous voice is re-tuned.

for example :

on MIDI	description	result
90 3C 40	Note on C4	C4 on
B0 54 3C	LGC from C4	no change
90 40 40	Note on E4	Re-tuning from C4 to E4
90 3C 00	Note off C4	no change
90 40 00	Note off E4	E4 off

○EFFECT1 DEPTH (reverb send depth)

status second third
 BnH 5BH vvH

n = MIDI channel number :0H - FH (1 - 16)
 vv = reverb send depth :00H - 7FH (0 - 127)

○EFFECT3 DEPTH (chorus send depth)

status second third
 BnH 5DH vvH

n = MIDI channel number :0H - FH (1 - 16)
 vv = chorus send depth :00H - 7FH (0 - 127)

○NRPN MSB/LSB

status second third
 BnH 63H mmH
 BnH 62H llH

n = MIDI channel number :0H - FH (1 - 16)
 mm = MSB of the specified parameter by NRPN
 ll = LSB of the specified parameter by NRPN

* These messages are recognized when "RX.NRPN = ON".

** NRPN **
 NRPN (Non Registered Parameter Number) is an expanded message of the control change.
 Each function of NRPN is described by manufacture.
 You can change the value of several SCC - 1 parameters.
 Set first NRPN MSB/LSB before send data entry.

SCC - 1 can receive parameters as shown below ;

NRPN MSB LSB	DATA ENTRY MSB LSB	description
01H 08H	mmH 11H	VIBRATE RATE mm : 0EH - 40H - 72H (-50 - 0 - +50) ll : Ignored
01H 09H	mmH 11H	VIBRATE DEPTH mm : 0EH - 40H - 72H (-50 - 0 - +50) ll : Ignored
01H 0AH	mmH 11H	VIBRATE DELAY mm : 0EH - 40H - 72H (-50 - 0 - +50) ll : Ignored
01H 20H	mmH 11H	TVF CUTOFF FREQUENCY mm : 0EH - 40H - 72H (-50 - 0 - +50) ll : Ignored
01H 21H	mmH 11H	TVF RESONANCE mm : 0EH - 40H - 72H (-50 - 0 - +50) ll : Ignored
01H 63H	mmH 11H	TVF&TVA ENV. ATTACK TIME mm : 0EH - 40H - 72H (-50 - 0 - +50) ll : Ignored
01H 64H	mmH 11H	TVF&TVA ENV. DECAY TIME mm : 0EH - 40H - 72H (-50 - 0 - +50) ll : Ignored
01H 66H	mmH 11H	TVF&TVA ENV. RELEASE TIME mm : 0EH - 40H - 72H (-50 - 0 - +50) ll : Ignored
18H rrH	mmH 11H	PITCH COARSE OF DRUM TONE mm : 00H - 40H - 7FH (-64 - 0 - semitone) ll : Ignored
1AH rrH	mmH 11H	TVA LEVEL OF DRUM TONE mm : 00H - 7FH <zero - maximum> ll : Ignored
1CH rrH	mmH 11H	PANPOT OF DRUM TONE mm : 00H <Random> 01H - 40H - 7FH <Left - Center - Right> ll : Ignored
1DH rrH	mmH 11H	REVERB SEND DEPTH OF DRUM TONE mm : 00H - 7FH <zero - maximum> ll : Ignored
1EH rrH	mmH 11H	CHORUS SEND DEPTH OF DRUM TONE mm : 00H - 7FH <zero - maximum> ll : Ignored

* rr : key number of drum tone

* VIBRATE RATE, VIBRATE DEPTH, VIBRATE DELAY, TVF CUTOFF FREQUENCY, TVF RESONANCE, TVF & TVA ENV. ATTACK TIME, TVF & TVA ENV. DECAY TIME and TVF & TVA ENV. RELEASE TIME (relative change on specified channel)

* PITCH COARSE OF DRUM TONE, TVA LEVEL OF DRUM TONE, PANPOT OF DRUM TONE and REVERB SEND DEPTH OF DRUM TONE (absolute change on specified drum tone)

○ RPN MSB/LSB

<u>status</u>	<u>second</u>	<u>third</u>
BnH	65H	mmH
BnH	64H	llH

n = MIDI channel number : 0H - FH (1 - 16)
 mm = MSB of the specified parameter by RPN
 ll = MSB of the specified parameter by RPN

* These messages are recognized when "RX.RPN = ON".

** RPN **

RPN (Registered Parameter Number) is the expand message of control change. Each function of RPN is described by MIDI. You can change the value of RPN parameters. First, set RPN MSB/LSB before send data entry.

SCC - 1 can receive Pitch bend sensitivity (RPN # 0), Master fine tuning (RPN # 1), Master coarse tuning (RPN # 2) and RPN reset (RPN # 16383).

RPN MSB LSB	DATA ENTRY MSB LSB	description
00H 00H	mmH 11H	PITCH BEND SENSITIVITY mm : 00H - 18H (0 - 24 semitone) ll : ignored (Up to 2 octaves, power on default is two semitones)
00H 01H	mmH 11H	MASTER FINE TUNING mm, ll : 00H, 00H - 40H, 00H - 7FH, 7FH (-8192*100/8192 - 0 - +8191*100/8192 cent)
00H 02H	mmH 11H	MASTER COARSE TUNING mm : 28H - 40H - 58H (-24 - 0 - +24 semitone) ll : ignored
7FH 7FH	mmH 11H	RPN RESET Return to no specified parameter of RPN and NRPN. Current setting value is no change. mm, ll : ignored

● PROGRAM CHANGE

<u>status</u>	<u>second</u>
CnH	ppH

n = MIDI channel number : 0H - FH (1 - 16)
 pp = program number : 00H - 7FH (1 - 128)

* This message is recognized when "RX.PROGRAM CHANGE = ON".

● CHANNEL PRESSURE

<u>Status</u>	<u>Second</u>
DnH	vvH

n = MIDI channel number : 0H - FH (1 - 16)
 vv = value : 00H - 7FH (0 - 127)

* This message is recognized when "RX.CH PRESSURE = ON" and set on "CA1 CONTROLLER FUNCTION".

● PITCH BEND CHANGE

<u>status</u>	<u>second</u>	<u>third</u>
EnH	llH	mmH

n = MIDI channel number : 0H - FH (1 - 16)
 mm, ll = value : 00H, 00H - 40H, 00H - 7FH, 7FH
 (- 8192 - 0 - + 8191)

* This message is recognized when "RX.PITCH BEND = ON" and set on "BEND CONTROLLER FUNCTION".

■ CHANNEL MODE MESSAGE

● ALL SOUNDS OFF

<u>status</u>	<u>second</u>	<u>third</u>
BnH	78H	00H

n = MIDI channel number : 0H - FH (1 - 16)

* When "ALL SOUNDS OFF" is received, all sounds of specified channel turn off immediately. However, the state of channel message is no change.

● RESET ALL CONTROLLERS

<u>status</u>	<u>second</u>	<u>third</u>
BnH	79H	00H

n = MIDI channel number : 0H - FH (1 - 16)

* When "RESET ALL CONTROLLERS" is received, controller value of specified channel return to default at power on.

controller	value
PITCH BEND CHANGE	± 0 (Center)
POLYPHONIC KEY PRESSURE	0 (off)
CHANNEL PRESSURE	0 (off)
MODULATION	0 (off)
EXPRESSION	127 (maximum)
HOLD1	0 (off)
PORTAMENTO	0 (off)
SOSTENUTO	0 (off)
SOFT	0 (off)
RPN	No specified parameter, value is no change.
NRPN	No specified parameter, value is no change.

● ALL NOTES OFF

<u>status</u>	<u>second</u>	<u>third</u>
BnH	7BH	00H

n = MIDI channel number : 0H - FH (1 - 16)

* When "ALL NOTES OFF" is received, all on state notes turn to off in the specified channel. However, sound remains when hold1 and/or sostenuto is on.

● OMNI OFF

<u>status</u>	<u>second</u>	<u>third</u>
BnH	7CH	00H

n = MIDI channel number : 0H - FH (1 - 16)

* OMNI OFF is only recognized as "ALL NOTES OFF". Mode dosen't change.

● OMNI ON

<u>status</u>	<u>second</u>	<u>third</u>
BnH	7DH	00H

n = MIDI channel number : 0H - FH (1 - 16)

* OMNI ON is only recognized as "ALL NOTES OFF". Mode dosen't change, still OMNI OFF.

● MONO

<u>status</u>	<u>second</u>	<u>third</u>
BnH	7EH	mmH

n = MIDI channel number : 0H - FH (1 - 16)
 mm = number of mono : 00H - 10H (0 - 16)

* MONO is recognized as "ALL SOUNDS OFF". And the specified channel turns to Mode4 (m = 1), even if mm is not equal to 1 (mm is ignored).

● POLY

status	second	third
BnH	7FH	00H

n = MIDI channel number : 0H - FH (1 - 16)

*POLY is recognized as "ALL SOUNDS OFF".
And the specified channel turns to Mode3.

■ SYSTEM REALTIME MESSAGE

● ACTIVE SENSING

status
FEH

*Having received "ACTIVE SENSING", SCC-1 expects the interval of any data octet up to 300 ms. If the interval is over 420 ms, SCC-1 does "ALL SOUNDS OFF", "ALL NOTES OFF" and "RESET ALL CONTROLLERS" and turns on normal operation (will not check interval time).

■ SYSTEM EXCLUSIVE MESSAGE

status	data
FOH	iiH,ddH,,,,,eeH
F7H	

FOH	: system exclusive
ii = ID number	: 41H (65)
dd,,,ee = data	: 00H - 7FH (0 - 127)
F7H	: EOX (end of exclusive/system common)

* Refer to section 2, 3.

2.EXCLUSIVE COMMUNICATIONS

SCC-1 can transmit and receive the patch parameters using system exclusive message.

Model ID of SCC-1 is 42H and device ID is 10H.

■ ONE WAY COMMUNICATION

● DATA SET 1, DT1 : 12H

byte	description
F0H	exclusive status
41H	manufacturer's ID (Roland)
10H	device ID (UNIT#17)
42H	model ID (SCC-1)
12H	command ID (DT1)
aaH	address MSB
bbH	address
ccH	address LSB
ddH	data
:	:
ddH	data
sum	check sum
F7H	EOX (end of exclusive)

3.PARAMETER ADDRESS MAP

*The address and size are described with 7-bit hexadecimal.
This means that the next 00 00 7F is 00 01 00.

address	MSB	LSB
binary	0aaa aaaa	0bbb bbbb
hexadecimal	AA	BB

size	MSB	LSB
binary	0sss ssss	0ttt tttt
hexadecimal	SS	TT

■ PARAMETER BASE ADDRESS

There are two types of the SCC-1 exclusive message. One is an individual parameter communication, another is a bulk dump communication.

Coarse address map of the exclusive communication is shown below;

● INDIVIDUAL

address	block	sub block	notes
40 00 00	SYSTEM PARAMETERS		*3-1
40 01 00	PATCH PARAMETERS	PATCH COMMON	*3-2-1
40 10 00		PATCH BLOCK 0	*3-2-2
:		:	
40 1F 00		PATCH BLOCK F	
40 20 00		PATCH BLOCK 0	:
:		:	
40 2F 00		PATCH BLOCK F	
41 00 00	DRUM SETUP PARAMETERS		*3-3

Notes : using address of the individual parameter

*One system exclusive message "F0 F7" can only have one parameter.

*3-1 SYSTEM PARAMETERS

address	data	description
40 00 00	0018 - 0400 - 07E8	MASTER TUNE (-100.0 - 0 - +100.0 cent) *use nibblized data : 00 00 01 08H - 00 04 00 00H - 00 07 0E 08H *size 00 00 04H
40 00 04	00 - 7F	MASTER VOLUME (0 - 127)
40 00 05	28 - 40 - 58	MASTER KEY-SHIFT (-24 - 0 - +24 semitones)
40 00 06	01 - 40 - 7F	MASTER PAN <Left - Center - Right>
40 00 7E	00 - 7F	LGC CONTROLLER NUMBER (0 - 127) (default = 54H)
40 00 7F	00	Reset 00H = All Parameters Reset (Default) 42H = Variations Reset (Capital)

for example :

As you set +100.0 cent for master tune, you should send the message as follow.

F0 41 10 42 12 40 00 00 00 07 0E 08 23 F7
 └ address └ data └ checksum

As you set 100(decimal) for master volume, you should send the message as follow.

F0 41 10 42 12 40 00 04 64 58 F7
 └ address └ data └ checksum

*The error checking process uses a checksum that provides a bit pattern where the least significant 7 bit are zero when values for an address, size, and that checksum are summed.

*3-2 PATCH PARAMETERS

*3-2-1 PATCH COMMON

address	data	description
40 01 00	20 - 7F	PATCH NAME (16 ASCII characters) *size 00 00 10H
40 01 10	00 - 18	PARTIAL RESERVE part number 0 - F (0 - 24) *The total number of partial reserves must be 24 or less. All partial reserves must be sent as apackage of 16 parts. *size 00 00 10H
40 01 20	00 - 0F	ASSIGNER SEPARATE WALL 0 - 15 [top part number of the wall]
40 01 30	00 - 07	REVERB MACRO 00 : room 1 01 : room 2 02 : room 3 03 : hall 1 04 : hall 2 05 : plate 06 : delay 07 : panning delay
40 01 31	00 - 07	REVERB CHARACTER
40 01 32	00 - 07	REVERB PRE-LPF
40 01 33	00 - 7F	REVERB LEVEL
40 01 34	00 - 7F	REVERB TIME
40 01 35	00 - 7F	REVERB DELAY FEEDBACK
40 01 36	00 - 7F	REVERB SEND LEVEL TO CHORUS
40 01 38	00 - 07	CHORUS MACRO 00 : chorus 1 01 : chorus 2 02 : chorus 3 03 : chorus 4 04 : feedback chorus 05 : flanger 06 : short delay 07 : short delay (FB)
40 01 39	00 - 07	CHORUS PRE-LPF
40 01 3A	00 - 7F	CHORUS LEVEL
40 01 3B	00 - 7F	CHORUS FEEDBACK
40 01 3C	00 - 7F	CHORUS DELAY
40 01 3D	00 - 7F	CHORUS RATE
40 01 3E	00 - 7F	CHORUS DEPTH
40 01 3F	00 - 7F	CHORUS SEND LEVEL TO REVERB

*3-2-2 PATCH BLOCK

*n = part number : 0 - F (not equal to MIDI channel)
 *x = MIDI channel number : 0 - F (1 - 16)
 *4 : SCC-1 can be controlled by contoroll change.

address	data	description
40 In 00	00 - 7F	tone number bank select #4
40 In 01#	00 - 7F	program change #4
40 In 02	00 - 0F, 10	RX.CHANNEL (1 - 16, OFF)
40 In 03	00 - 01	RX.PITCH BEND (OFF / ON)
40 In 04	00 - 01	RX.CH PRESSURE(CAF) (OFF / ON)
40 In 05	00 - 01	RX.PROGRAM CHANGE (OFF / ON)
40 In 06	00 - 01	RX.CONTROL CHANGE (OFF / ON)
40 In 07	00 - 01	RX.POLY PRESSURE(PAF) (OFF / ON)
40 In 08	00 - 01	RX.NOTE MESSAGE (OFF / ON)
40 In 09	00 - 01	RX.RPN (OFF / ON)
40 In 0A	00 - 01	RX.NRPN (OFF / ON)
40 In 0B	00 - 01	RX.MODURATION (OFF / ON)
40 In 0C	00 - 01	RX.VOLUME (OFF / ON)
40 In 0D	00 - 01	RX.PANPOT (OFF / ON)
40 In 0E	00 - 01	RX.EXPRESSION (OFF / ON)
40 In 0F	00 - 01	RX.HOLD1 (OFF / ON)
40 In 10	00 - 01	RX.PORTAMENTO (OFF / ON)
40 In 11	00 - 01	RX.SOSTENUTO (OFF / ON)
40 In 12	00 - 01	RX.SOFT (OFF / ON)
40 In 13	00 - 01	MONO/POLY MODE 00 = MONO #4 01 = POLY
40 In 14	00 - 02	ASSIGN MODE 00 = single (default at n= 0) 01 = limited-multi (default at n≠0) 02 = full-multi
40 In 15	00 - 02	USE FOR RHYTHM PART 00 = off (default at n≠0) 01 = map1 (default at n= 0) 02 = map2
40 In 16	28 - 40 - 58	PITCH KEY SHIFT (-24 - 0 - +24 semitone)
40 In 17	08 - 40 - F8	PITCH OFFSET FINE (-12.0 - 0 - +12.0 Hz) use niblized data: 00 08H - 04 00H - 0F 08H *size 00 00 02H

40 In 19	00 - 7F	PART LEVEL #4
40 In 1A	00 - 7F	VELOCITY SENSE DEPTH
40 In 1B	00 - 7F	VELOCITY SENSE OFFSET
40 In 1C	00, 01-40-7F	PART PANPOT 00 = Random 01-40-7F = Left-Center-Right #4
40 In 1D	00 - 7F	KEY RANGE LOW <C-1 - G9>
40 In 1E	00 - 7F	KEY RANGE HIGH <C-1 - G9>
40 In 1F	00 - 7F	CC1 CONTROLLER NUMBER
40 In 20	00 - 7F	CC2 CONTROLLER NUMBER
40 In 21	00 - 7F	CHORUS SEND DEPTH #4
40 In 22	00 - 7F	REVERB SEND DEPTH #4
40 In 30	0E - 40 - 72	VIBRATE RATE (-50 - 0 - +50) #4
40 In 31	0E - 40 - 72	VIBRATE DEPTH (-50 - 0 - +50)
40 In 32	0E - 40 - 72	TVF CUTOFF FREQUENCY (-50 - 0 - +50)
40 In 33	0E - 40 - 72	TVF RESONANCE (-50 - 0 - +50)
40 In 34	0E - 40 - 72	TVF&TVA ENV. ATTACK TIME (-50 - 0 - +50)
40 In 35	0E - 40 - 72	TVF&TVA ENV. DECAY TIME (-50 - 0 - +50)
40 In 36	0E - 40 - 72	TVF&TVA ENV. RELEASE TIME (-50 - 0 - +50)
40 In 37	0E - 40 - 72	VIBRATE DELAY (-50 - 0 - +50)
40 In 40	00 - 40 - 7F	SCALE TUNING C, C#, D, D#, E, F, F#, G, G#, A, A#, B (-64 - 0 - +63 cent) *size 00 00 0CH
40 2n 00	28 - 40 - 58	MOD PITCH CONTROL (-24 - 0 - +24 semitone)
40 2n 01	00 - 40 - 7F	MOD TVF CUTOFF CONTROL (-9600 - 0 - +9600 cent)
40 2n 02	00 - 40 - 7F	MOD AMPLITUDE CONTROL (-100.0 - 0 - +100.0 %)
40 2n 03	00 - 40 - 7F	MOD LFO1 RATE CONTROL (-10.0 - 0 - +10.0 Hz)
40 2n 04	00 - 7F	MOD LFO1 PITCH DEPTH (0 - 600 cent)
40 2n 05	00 - 7F	MOD LFO1 TVF DEPTH (0 - 2400 cent)
40 2n 06	00 - 7F	MOD LFO1 TVA DEPTH (0 - 100.0 %)
40 2n 07	00 - 40 - 7F	MOD LFO2 RATE CONTROL (-10.0 - 0 - +10.0 Hz)
40 2n 08	00 - 7F	MOD LFO2 PITCH DEPTH (0 - 600 cent)
40 2n 09	00 - 7F	MOD LFO2 TVF DEPTH (0 - 2400 cent)
40 2n 0A	00 - 7F	MOD LFO2 TVA DEPTH (0 - 100.0 %)
40 2n 10	28 - 40 - 58	BEND PITCH CONTROL (-24 - 0 - +24 semitone)
40 2n 11	00 - 40 - 7F	BEND TVF CUTOFF CONTROL (-9600 - 0 - +9600 cent)
40 2n 12	00 - 40 - 7F	BEND AMPLITUDE CONTROL (-100.0 - 0 - +100.0 %)
40 2n 13	00 - 40 - 7F	BEND LFO1 RATE CONTROL (-10.0 - 0 - +10.0 Hz)
40 2n 14	00 - 7F	BEND LFO1 PITCH DEPTH (0 - 600 cent)
40 2n 15	00 - 7F	BEND LFO1 TVF DEPTH (0 - 2400 cent)
40 2n 16	00 - 7F	BEND LFO1 TVA DEPTH (0 - 100.0 %)
40 2n 17	00 - 40 - 7F	BEND LFO2 RATE CONTROL (-10.0 - 0 - +10.0 Hz)
40 2n 18	00 - 7F	BEND LFO2 PITCH DEPTH (0 - 600 cent)
40 2n 19	00 - 7F	BEND LFO2 TVF DEPTH (0 - 2400 cent)
40 2n 1A	00 - 7F	BEND LFO2 TVA DEPTH (0 - 100.0 %)
40 2n 20	28 - 40 - 58	CAF PITCH CONTROL (-24 - 0 - +24 semitone)
40 2n 21	00 - 40 - 7F	CAF TVF CUTOFF CONTROL (-9600 - 0 - +9600 cent)
40 2n 22	00 - 40 - 7F	CAF AMPLITUDE CONTROL (-100.0 - 0 - +100.0 %)
40 2n 23	00 - 40 - 7F	CAF LFO1 RATE CONTROL (-10.0 - 0 - +10.0 Hz)
40 2n 24	00 - 7F	CAF LFO1 PITCH DEPTH (0 - 600 cent)
40 2n 25	00 - 7F	CAF LFO1 TVF DEPTH (0 - 2400 cent)
40 2n 26	00 - 7F	CAF LFO1 TVA DEPTH (0 - 100.0 %)
40 2n 27	00 - 40 - 7F	CAF LFO2 RATE CONTROL (-10.0 - 0 - +10.0 Hz)
40 2n 28	00 - 7F	CAF LFO2 PITCH DEPTH (0 - 600 cent)
40 2n 29	00 - 7F	CAF LFO2 TVF DEPTH (0 - 2400 cent)
40 2n 2A	00 - 7F	CAF LFO2 TVA DEPTH (0 - 100.0 %)
40 2n 30	28 - 40 - 58	PAF PITCH CONTROL (-24 - 0 - +24 semitone)
40 2n 31	00 - 40 - 7F	PAF TVF CUTOFF CONTROL (-9600 - 0 - +9600 cent)
40 2n 32	00 - 40 - 7F	PAF AMPLITUDE CONTROL (-100.0 - 0 - +100.0 %)
40 2n 33	00 - 40 - 7F	PAF LFO1 RATE CONTROL (-10.0 - 0 - +10.0 Hz)
40 2n 34	00 - 7F	PAF LFO1 PITCH DEPTH (0 - 600 cent)
40 2n 35	00 - 7F	PAF LFO1 TVF DEPTH (0 - 2400 cent)
40 2n 36	00 - 7F	PAF LFO1 TVA DEPTH (0 - 100.0 %)
40 2n 37	00 - 40 - 7F	PAF LFO2 RATE CONTROL (-10.0 - 0 - +10.0 Hz)
40 2n 38	00 - 7F	PAF LFO2 PITCH DEPTH (0 - 600 cent)
40 2n 39	00 - 7F	PAF LFO2 TVF DEPTH (0 - 2400 cent)
40 2n 3A	00 - 7F	PAF LFO2 TVA DEPTH (0 - 100.0 %)

40 2n 40	28 - 40 - 58	CC1 PITCH CONTROL (-24 - 0 - +24 semitone)
40 2n 41	00 - 40 - 7F	CC1 TVF CUTOFF CONTROL (-9600 - 0 - +9600 cent)
40 2n 42	00 - 40 - 7F	CC1 AMPLITUDE CONTROL (-100.0 - 0 - +100.0 %)
40 2n 43	00 - 40 - 7F	CC1 LFO1 RATE CONTROL (-10.0 - 0 - +10.0 Hz)
40 2n 44	00 - 7F	CC1 LFO1 PITCH DEPTH (0 - 600 cent)
40 2n 45	00 - 7F	CC1 LFO1 TVF DEPTH (0 - 2400 cent)
40 2n 46	00 - 7F	CC1 LFO1 TVA DEPTH (0 - 100.0 %)
40 2n 47	00 - 40 - 7F	CC1 LFO2 RATE CONTROL (-10.0 - 0 - +10.0 Hz)
40 2n 48	00 - 7F	CC1 LFO2 PITCH DEPTH (0 - 600 cent)
40 2n 49	00 - 7F	CC1 LFO2 TVF DEPTH (0 - 2400 cent)
40 2n 4A	00 - 7F	CC1 LFO2 TVA DEPTH (0 - 100.0 %)
40 2n 50	28 - 40 - 58	CC2 PITCH CONTROL (-24 - 0 - +24 semitone)
40 2n 51	00 - 40 - 7F	CC2 TVF CUTOFF CONTROL (-9600 - 0 - +9600 cent)
40 2n 52	00 - 40 - 7F	CC2 AMPLITUDE CONTROL (-100.0 - 0 - +100.0 %)
40 2n 53	00 - 40 - 7F	CC2 LFO1 RATE CONTROL (-10.0 - 0 - +10.0 Hz)
40 2n 54	00 - 7F	CC2 LFO1 PITCH DEPTH (0 - 600 cent)
40 2n 55	00 - 7F	CC2 LFO1 TVF DEPTH (0 - 2400 cent)
40 2n 56	00 - 7F	CC2 LFO1 TVA DEPTH (0 - 100.0 %)
40 2n 57	00 - 40 - 7F	CC2 LFO2 RATE CONTROL (-10.0 - 0 - +10.0 Hz)
40 2n 58	00 - 7F	CC2 LFO2 PITCH DEPTH (0 - 600 cent)
40 2n 59	00 - 7F	CC2 LFO2 TVF DEPTH (0 - 2400 cent)
40 2n 5A	00 - 7F	CC2 LFO2 TVA DEPTH (0 - 100.0 %)

*3 - 3 DRUM SETUP PARAMETER

* m = map number :0H - 1H
(0 = map1, 1 = map2)

* rr = drums part key number :00H - 7FH (0 - 127)

* 4 :SCC - 1 can be controlled
by contoroll change.

address	data	description
41 #0 00	20 - 7F	DRUMS MAP NAME (12 ASCII character) #SIZE 00 00 0CH
41 #1 rr	00 - 7F	PLAY KEY NUMBER pitch coarse #4
41 #2 rr	00 - 7F	LEVEL #4
41 #3 rr	00 - 7F	ASSIGN GROUP NUMBER (non. 1 - 127)
41 #4 rr	00,01-40-7F	PANPOT <random, Left-Center-Right> #4
41 #5 rr	00 - 7F	REVERB DEPTH #4
41 #6 rr	00 - 7F	multiplicand of the part reverb depth CHORUS DEPTH #4
41 #7 rr	00 - 01	multiplicand of the part chorus depth RX.NOTE OFF (OFF / ON)
41 #8 rr	00 - 01	RX.NOTE ON (OFF / ON)

■ *Specifications*

[**Sound Source**] (conforming to GS Format)

Number of Parts: 16
Maximum Polyphony: 24 (Voices)
Effects: Reverb, Chorus

[**MIDI Processing Unit**] (MPU-401 compatible)

Interrupt level switching
I/O address switching

[**Others**]

Connectors: mini-DIN (MIDI OUT, MIDI IN)
Audio outs × 2 (L, R)
Headphone jack (mini-stereo)
Power supply: Supplied by the computer
Power consumption: 200 mA (DC +5 V)
20 mA (DC +12 V)
Maximum external dimensions: 23 (W) × 198 (D) × 126 (H) mm
15/16"(W) × 7-13/16"(D) × 5"(H) inches
Weight: 170 g (without cable)
6 oz
Accessories: Audio cables -- 2
mini-DIN MIDI converter cables -- 2

For more detailed information about the inner workings of the SCC-1 MIDI processing unit, read the MPU-401 reference manual, which is sold separately.

* The specifications for this product are subject to change without prior notice.

For Germany

Bescheinigung des Herstellers/Importeurs

Hiermit wird bescheinigt, daß der/die/das

GS SOUND CARD SCC-1

(Gerät. Typ. Bezeichnung)

in Übereinstimmung mit den Bestimmungen der

Amtsbl. Vfg 1046/1984

(Amtsblattverfügung)

funk-entstört ist.

Der Deutschen Bundespost wurde das Inverkehrbringen dieses Gerätes angezeigt und die Berechtigung zur Überprüfung der Serie auf Einhaltung der Bestimmungen eingeräumt.

Roland Corporation Osaka/Japan

Name des Herstellers/Importeurs

For the USA

RADIO AND TELEVISION INTERFERENCE

WARNING — This equipment has been verified to comply with the limits for a Class B computing device, pursuant to Subpart J, of Part 15, of FCC rules. Operation with non-certified or non-verified equipment is likely to result in interference to radio and TV reception.

The equipment described in this manual generates and uses radio frequency energy. If it is not installed and used properly, that is, in strict accordance with our instructions, it may cause interference with radio and television reception. This equipment has been tested and found to comply with the limits for a Class B computing device in accordance with the specifications in Subpart J, of Part 15, of FCC Rules. These rules are designed to provide reasonable protection against such a interference in a residential installation. However, there is no guarantee that the interference will not occur in a particular installation. If this equipment does cause interference to radio or television reception, which can be determined by turning the equipment on and off, the user is encouraged to try to correct the interference by the following measure:

- Disconnect other devices and their input/output cables one at a time. If the interference stops, it is caused by either the other device or its I/O cable. These devices usually require Roland designated shielded I/O cables. For Roland devices, you can obtain the proper shielded cable from your dealer. For non Roland devices, contact the manufacturer or dealer for assistance.
- If your equipment does cause interference to radio or television reception, you can try to correct the interference by using one or more of the following measures.
- Turn the TV or radio antenna until the interference stops.
- Move the equipment to one side or the other of the TV or radio.
- Move the equipment farther away from the TV or radio.
- Plug the equipment into an outlet that is on a different circuit than the TV or radio. (That is, make certain the equipment and the radio or television set are on circuits controlled by different circuit breakers or fuses.)
- Consider installing a rooftop television antenna with coaxial cable lead-in between the antenna and TV. If necessary, you should consult your dealer or an experienced radio/television technician for additional suggestions. You may find helpful the following booklet prepared by the Federal Communications Commission: "How to Identify and Resolve Radio — TV Interference Problems"

This booklet is available from the U.S. Government Printing Office, Washington, D.C., 20402, Stock No. 004-000-00345-4.

For Canada

CLASS B

NOTICE

This digital apparatus does not exceed the Class B limits for radio noise emissions set out in the Radio Interference Regulations of the Canadian Department of Communications.

CLASSE B

AVIS

Cet appareil numérique ne dépasse pas les limites de la classe B au niveau des émissions de bruits radioélectriques fixés dans le Règlement des signaux parasites par le ministère canadien des Communications.

Information

● When you need repair service, call your local Roland Service Station or the authorized Roland distributor in your country as shown below.

U. S. A.

Roland Corp US
7200 Dominion Circle
Los Angeles, CA. 90040 - 3647
U. S. A.
☎ (213)685 - 5141

CANADA

Roland Canada Music Ltd.
(Head Office)
5480 Parkwood
Richmond B. C., V6V 2M4
CANADA
☎ (604)270 - 6626

Roland Canada Music Ltd.
9425 Transcanadienne
Service Rd. N.,
St Laurent, Quebec H4S 1V3
CANADA
☎ (514)335 - 2009

Roland Canada Music Ltd.
346 Watline Avenue,
Mississauga, Ontario L4Z 1X2
CANADA
☎ (416)890 - 6488

AUSTRALIA

Roland Corporation
(Australia) Pty. Ltd.
(Head Office)
38 Campbell Avenue
Dee Why West. NSW 2099
AUSTRALIA
☎ (02)982 - 8266

Roland Corporation
(Australia) Pty. Ltd.
(Melbourne Office)
50 Garden Street
South Yarra, Victoria 3141
AUSTRALIA
☎ (03)241 - 1254

NEW ZEALAND

Roland Corporation (NZ) Ltd.
97 Mt. Eden Road, Mt. Eden,
Auckland 3
NEW ZEALAND
☎ (09)3098 - 715

UNITED KINGDOM

Roland(UK)Ltd.
Rye Close
Ancells Business Park
Fleet
Hampshire GU13 8UY
UNITED KINGDOM
☎ 0252 - 816181

GERMANY

Roland Elektronische
Musikinstrumente
Handelsgesellschaft mbH.
Oststrasse 96,
2000 Norderstedt
GERMANY
☎ 040/52 60 090

BELGIUM/HOLLAND/ LUXEMBOURG

Roland Benelux N. V.
Houtstraat 1
B - 2260 Oevel - Westerlo
BELGIUM
☎ (0032)14 - 575811

DENMARK

Roland Scandinavia as
Langebrogade 6
Box 1937
DK - 1023 Copenhagen K.
DENMARK
☎ 31 - 95 31 11

SWEDEN

Roland Scandinavia as
DanvikCenter 28 A, 2 tr.
S - 131 30 Nacka,
SWEDEN
☎ 08 - 702 00 20

NORWAY

Roland Scandinavia
Avd. Norge
Lilleakerveien 2
Postboks 95 Lilleaker
N - 0216 Oslo 2
NORWAY
☎ 02 - 73 00 74

FINLAND

Fazer Musik Inc.
Länsituulentie
POB 169
SF - 02101 Espoo
FINLAND
☎ 0 - 43 50 11

ITALY

Roland Italy S. p. A.
Viale delle Industrie 8
20020 ARESE MILANO
ITALY
☎ 02 - 93581311

SPAIN

Roland Electronics
de España, S. A.
Calle Bolivia 239
08020 Barcelona
SPAIN
☎ 93 - 308 - 1000

SWITZERLAND

Musitronic AG
Gerberstrasse 5, CH - 4410
Liestal
SWITZERLAND
☎ 061/921 16 15

Roland CK (Switzerland) AG
Hauptstrasse 21/Postfach
CH - 4456 Tenniken
SWITZERLAND
☎ 061/98 60 55
Repair Service by Musitronic AG

FRANCE

Musikengro
102 Avenue Jean - Jaures
69007 Lyon Cedex 07
FRANCE
☎ (7)858 - 54 60

Musikengro
(Paris Office)
Centre Region Parisienne
41 rue Charles - Fourier,
94400 Vitry s/Seine
FRANCE
☎ (1)4680 86 62

AUSTRIA

E. Dematte & Co.
Neu - Rum Siemens - Strasse 4
A - 6021 Innsbruck Box 591
AUSTRIA
☎ (0512)63 451

GREECE

V. Dimitriadis & Co. Ltd.
2 Phidiou Str., GR 106 78
Athens
GREECE
☎ 1 - 3620130

PORTUGAL

Casa Caius Instrumentos
Musicais Lda.
Rua de Santa Catarina 131
Porto
PORTUGAL
☎ 02 - 38 44 56

HUNGARY

Intermusica Ltd.
Warehouse Area 'DEPO'
Budapest, P.O. Box 3,
2045 Torokbalint
HUNGARY
☎ (1)1868905

ISRAEL

D.J.A. International Ltd.
25 Pinsky St.,
Tel Aviv
ISRAEL
☎ 03 - 283015

BRAZIL

FORESIGHT Corporation
R. Alvarenga 591
CEP - 05509 Sao Paulo
BRAZIL
FAX: (011)210 - 0286

HONG KONG

Tom Lee Music Co., Ltd.
Service Division
22 - 32 Pun Shan Street,
Tsuen Wan,
New Territories,
HONG KONG
☎ 415 - 0911

SINGAPORE

Swee Lee Company
Bras Basah Complex #03 - 23
Singapore 0178
SINGAPORE
☎ 3367886

THAILAND

Theera Music Co., Ltd.
330 Verng Nakorn Kasem, Soi 2
Bangkok 10100,
THAILAND
☎ 2248821

MALAYSIA

Syarikat Bentley
No.142, Jalan Bukit Bintang
55100 Kuala Lumpur
MALAYSIA
☎ 2421288

INDONESIA

PT Galestra Inti
Kompleks Perkantoran
Duta Merlin Blok C/59
Jl. Gajah mada No.3 - 5
Jakarta 10130
INDONESIA
☎ (021) 354604, 354606

TURKEY

Barkat Sanayi ve Ticaret
Siraselviler Cad. 86/6 Taksim
Istanbul
TURKEY
☎ 149 93 24

CYPRUS

Radex Sound Equipment Ltd.
17 Panteli Katelari Str.
P.O.Box 2046, Nicosia
CYPRUS
☎ 453426, 466423

As of JUL 7. 1991

CS SOUND CARD 

Roland Corporation

2604079200 '91-10-C3-22SY

MIDI Implementation Chart

Function ...	Transmitted	Recognized	Remarks
Basic Default Channel Changed	× ×	1 - 16 1 - 16 each	
Mode Default Messages Altered	× × *****	Mode 3 Mode 3, 4 (m = 1)	* 1
Note Number True Voice	× *****	0 - 127 0 - 127	
Velocity Note ON Note OFF	× ×	○ ×	
After Key's Touch Ch's	× ×	* 2 * 2	
Pitch Bender	×	○/× * 2	Resolution : 12 bit
Control Change	0, 32 × 1 × 5 × 6,38 × 7 × 10 × 11 × 64 × 65 × 66 × 67 × 84 × 91 × 93 × 98,99 × 100, 101 × 120 × 121 ×	○/× * 3 ○/× * 2 ○/× * 3 ○/× * 3 ○/× * 2 ○/× * 2 ○/× * 2 ○/× * 2 ○/× * 2 ○/× * 2 ○/× * 2 ○/× * 2 ○/× * 2 ○/× * 3 ○/× * 3 ○/× * 2 ○/× * 2 ○ ○	Bank select Modulation Portamento time Data entry Volume Panpot Expression Hold 1 Portamento Sostenuto Soft LGC Effect1 depth (reverb) Effect3 depth (chorus) NRPN LSB, MSB RPN LSB, MSB All sounds off Reset all controllers
Prog Change True #	× *****	○/× * 2 0 - 127	
System Exclusive	×	○	
System Common Song Pos Song Sel Tune	× × ×	× × ×	
System Real Time Clock Commands	× ×	× ×	
Aux Messages Local ON/OFF All Notes OFF Active Sense Reset	× × × ×	× ○ (123 - 125) ○ ×	
Notes	* 1 Recognize as m = 1 even if m ≠ 1. * 2 ○ × can be selectable. * 3 ○ × can be selectable, only using the receive switch of control change (all).		

Music Software for GS

GS music software takes advantage of one or more custom features of GS products, such as patch bank selections, alternate drum sets, or even track volume and mute functions.

Ballade (Mac/MS-DOS)
Dynaware USA, 950 Tower Lane #1150, Foster City, CA 94404 (415) 349-5700
16-track sequencer with mixing panel display, score editing and printing. Includes all GS patch selections, full reverb and chorus control, volume and pan faders, more. Reads/Writes SMF.

Band in a Box v.5 (Mac/MS-DOS/Windows)
PG Music, 111-266 Elmwood Ave, Buffalo, NY 14222 (416) 528-2368
Composition/accompaniment program, includes all GS patch selections, full reverb and chorus control, volume and pan adjust, works with Roland Intelligent Arrangers, more. Generate complete arrangements from your chord progressions in preset and programmable styles. Can also record melody, save as SMF.

Musicator GS (MS-DOS/Windows)
Thinkware (US Distributor), 130 9th St. #303, SF, CA 94103 (415) 255-2091
16 track sequencer with fader panel, score editing and printing. Includes all GS patch selections, full reverb and chorus control, volume and pan faders, parameter editing, more. Reads/Writes SMF.

Ludwig! (Windows)/ SongCanvas (MS-DOS)
Parker Adams Group, 12335 Santa Monica Blvd. Suite 124, Los Angeles, CA 90025 (310) 450-2175
Both editors are complete GS Editors, include a Quick Edit Screen for all 16 parts for easy mixing, saving and loading of multipart sounds. Also saves MIDIEX format files for importing to Cakewalk, Sequencer Plus, etc. Includes 256 Multipart Sound Library.
Complete GS sound editor.

GS and GM Standard Midi Files

A wide variety of songs in SMF format are available from music publishers and individual artists. All song data written in Roland's GS Format or General MIDI Standard will play exactly as intended on all Roland GS products.

Music Bytes
ProSonus, 11126 Weddington, N. Hollywood, CA 91601 (818) 766-5221

MusiClips
Joyetra, 333 Fifth Ave., Pelham, NY 10803 (914) 738-4500

invisible Touch
invisible Touch, PO Box 1651, Fair Oaks, CA 95628 (916) 729-2653

MIDI Sequences
Iran Tracks, 350 5th Ave. Suite 3304 New York NY 10118 (201) 383-6691

Song Canvas (MS-DOS/Windows)
Jeff Cazal, 13265 SW Cottontail, Beaverton OR 97005
Complete GS sound editor.

Power Chords (Windows)
Howling Dog Music, Kanata North Postal Outlet, Box 72071 Kanata, Ontario, Canada K2K 2P4, (613) 599-7927
Modular composition program, design your own guitar rhythms, drum patterns, chord progressions and more. Imports melodies and bass lines from SMF, exports songs to SMF.

Pro-Rec (sounds)
106 W 13th St #13, New York, NY 10011 (212) 675-5606;
(212) 627-3148 Demo Line
Sounds for SC-55 on various formats

Sound Source Unlimited (sounds)
2985 E Hillcrest DR. #A, Westlake Village, CA 91362 (805) 494-9996
Sounds for SC-55 on various formats

Midisoft Recording Session (Windows)
Midisoft, 15263 NE 90th ST. #9-10, Redmond, WA 98052 (206) 881-7176
Multi track sequencer with fader panel, score editing, printing etc. Includes GS patch selections, full reverb and chorus control, volume and pan faders, more. Available with Music Mentor or with various OEM hardware.

MAX (Mac)
Opcode Systems, 3950 Fabian Way #100, Palo Alto, CA 94303 (415) 856-3333

Multimedia Artists Songs
Parker Adams Group
12335 Santa Monica Blvd. #124, Los Angeles, CA 90025 (310) 450-2175

Music Interactive
Hal Leonard Publishing Corporation
7777 W. Bluemound Rd, P.O. Box 13819, Milwaukee, WI 53213 (800) 221-2774

Trycho Tunes
Trycho Music Int'l, 2166 W Brdwy. #330, Anaheim, CA 92804 (909) 696-3577

A World of Music Sampler
MidiSoft/MTA, PO Box 1000, Bellevue, WA 98009 (206) 881-7176

Turbo Music
RTG Music
130 E. 6th St., Cincinnati, OH 45202 (513) 381-0506

MIDI-aware Multimedia

Authoring & Presentation

Multimedia authoring software provides the means to combine a variety of visual and audio messages into either a single linear presentation or one that can be navigated by the user. These applications are all different in the types of visual information they present and levels of interactivity, but all play MIDI files along with visuals.

Icon Author (Windows)
AimTech, 20 Trafalgar Square, Nashua NH 03063 • (603) 883-0220

Toolbook Multimedia Edition, Compel, Multimedia Make Your Point, Media Blitz (Windows)
Asymetrix, 110 110th Ave NE #700, Bellevue WA 98004 • (206) 462-0501

Authorware Professional (Mac), Star (Windows)
Authorware, 625 N Michigan Ave #500, Chicago IL 60611 • (312) 751-5420

Multimedia Explorer (Windows)
Autodesk Multimedia, 2320 Marinship Way, Sausalito CA 94965 • (415) 491-8507

Animation Works Interactive (Windows), Add Impact (Windows)
Gold Disk, 385 VanNess Ave. Suite #110 Torrance, CA 90501 (310) 320-5080

New Wave (Windows)
Hewlett Packard, 974 East Arques Ave. Sunnyvale CA 94086 • (408) 720-3000

HSC Interactive (Windows)
HSC, 1661 Lincoln Blvd. #101, Santa Monica CA 90404 • (213) 392-8441

Audio Visual Connection (MS-DOS), Storyboard Live (MS-DOS)
Media Sorcery 1055 Joaquin Rd. Mountain View, CA 94043 • (800) 228-8584

Ask Me 2000 (MS-DOS), SST (Windows)
ICS, 7100 Northland Circle Suite 401 Minneapolis, MN 55428 (612) 531-0603

Action (Windows/Mac) Director (Mac)
MacroMedia, 600 Townsend, Ste. 310W, SF CA 94103 • (415) 442-0200

MIDI-aware Multimedia

Authoring & Presentation (cont'd)

Media Author (Windows)

Mathematica, 402 S. Kentucky Avenue,
Lakeland FL 33801 • (813) 682-1128

Harvard Graphics (MS-DOS), Harvard Graphics for Windows, Superbase 4 (Windows)

Software Publishing, 3165 Kifer Rd.
P.O. Box 54983 Santa Clara,
CA 95056-0983

Curtain Call (Windows)

Zuma Group Inc., 6733 North Black
Canyon, Phoenix AZ 85015 •
(602) 246-4238

On-line MIDI Forums

Musicians can retrieve music data
from these BBS services.

America Online (BBS; music SIG);
8619 Westwood Center Dr.
Vienna, VA, 22182;
tel (800) 227-6364 (voice)

CompuServe (BBS; music conference);
PO Box 20212 Columbus, OH 43220-
9922; tel. (800) 848-8199 (voice);
tel (800) 368-3343 (data & voice)

GEnie (BBS; MIDI and music confer-
ences); 401 NW Washinton St.
Rockville, MD 20849; tel. (800) 638-
8369 (data); tel. (800) 638-9636 (voice);

International MIDI User's Group
(MUG) (Newsletter, hotline); PO Box
615 Yonkers, NY 10703-0615; tel. (212)
465-3430 (24-hour hotline)
tel. (914) 667-4362 (voice)

MIDILink/Sound Management (BBS);
PO Box 396 Mundelein, IL 60060;
tel. (708) 949-MIDI (data)

PAN (BBS); PO Box 162 Skippack, PA
19474 tel. (215) 584-0300 (voice); tel.
(617) 676-0862 (1,200 baud);
tel. (617) 576-2981 (2,400 baud)

GS and GM compatible Game Software

The following companies have all announced support for Roland GS
and/or General MIDI music soundtracks in their games:

Sierra On-line
Micropose
Origin Systems
Interplay
Broderbund
Lucas Arts

Activision
New World Audio
Virgin Games
Bethesda Softworks
Electronic Arts

Most GS products also have an MT-32 mode which can be used with
many existing game soundtracks written for the MT-32 or LAPC-1.
However, soundtracks that include custom sounds may play
improperly.

Sequencing and Notation

Finale, Music Prose (Windows/Mac)
Coda, 6210 Bury Dr, Eden Praire, MN
55436-1718 (612) 937-9611

Copyist, Quickscore Deluxe (MS-
DOS), **Beyond** (Mac)
Dr. T, 220 Boylston St., Suite 206,
Chestnut Hill, MA 02167 (617) 224-6954

Concertware; Concertware+MIDI
(iMac)
Great Wave, 5353 Scotts Valley Dr.,
Scotts Valley, CA 95066 (408) 438-1990

Mosaic, Performer, Digital Performer
(Mac)
Mark of the Unicorn, 1280
Massachusetts Ave. Cambridge, MA
(617) 576-2760

Encore, Master Trax, Music Time,
Trax (Windows/Mac) **Passport Producer**
(MAC)
Passport, 100 Stone Pine Rd., Half
Moon Bay, CA 94019 (415) 726-0280

Cubase (Windows/Mac), **Cubase**
Audio (Mac)
Steinberg, 17700 Raymer, Suite 1001,
Northridge, CA 91325 (818) 993-4091

Cakewalk Pro (MS-DOS), **Cakewalk**
Pro Windows
Twelve-Tone, P.O. Box 760, Watertown,
MA 02272 (800) 234-1171

Sequencer Plus (MS-DOS)
Voyetra, 333 5th Ave., Dept B, Pelham,
NY 10803 (800) 233-9377

Cadenza (Windows), **MIDI MaxPak**
(Windows)
Big Noise Software, P.O. Box 23740,
Jacksonville, FL 32241 (904) 730-0754

Music Printer Plus (MS-DOS)
Temporal Acuity Prod., 300 120th Ave
NE, Building 1, Suite 200
Bellevue, WA 98005 (800) 426-2673

Texture (MS-DOS)
Magnetic Music, 647 W. Orange Grove,
Pomona, CA 91768 (909) 865-0407

Studio, Recording Session (Windows)
MIDISOFT, 15263 NE 90th St.
Redmond, WA 98052 (206) 881-7176

Personal Composer (Windows, MS-
DOS)
3213 West Wheeler St. Suite 140,
Seattle, WA 98199 (800) 446-8088

Vision, EZ-Vision, Studio Vision,
Musicshop (Mac)
Opcode, 3950 Fabian Way #100, Palo
Alto, CA 94303 (415) 856-3333

Roland®

Roland Corporation US 7200 Dominion Circle, Los Angeles, CA 90040

Telephone: (213) 685-5141 Fax: (213) 722-0911

IF YOU NEED A DIFFERENT DISK!

The enclosed disk(s) are high density format. If your drive can not read this format, you may obtain replacement disks directly from Roland.

Contact Roland Product Support at (213) 685-5141 x 770.
or send this form to:

Roland Corporation US
Software Services
7200 Dominion Circle
Los Angeles, CA 90040

To obtain replacement disks you must provide the serial number from your disk, and specify the size needed.

Disk Serial Number: _____

Size Needed: 800K MAC 1.2M PC

Ship to: Name: _____
Street: _____
City: _____
State: _____
Zip: _____
Phone: _____