

## L-12/L-20/L-20R audio driver version 2 supplementary manual

September 2020

Starting with L-12/L-20/L-20R driver version 2, post master fader signals can be set as channels 1/2 sent to the computer.

Post master fader signals can now be used with streaming and audio calling software that has input channels fixed to channels 1/2 sent to the computer.

This setting can be changed from the driver control panel. Setting procedures for Windows and Mac are explained below. L-12 screens are used in these explanations, but operations are the same when using an L-20 or L-20R.

### Windows

1. Open the Control Panel. Then, from the Hardware and Sound category, open the ZOOM L-12 Control Panel or the ZOOM L-20 Control Panel.
2. Open the Channel tab.

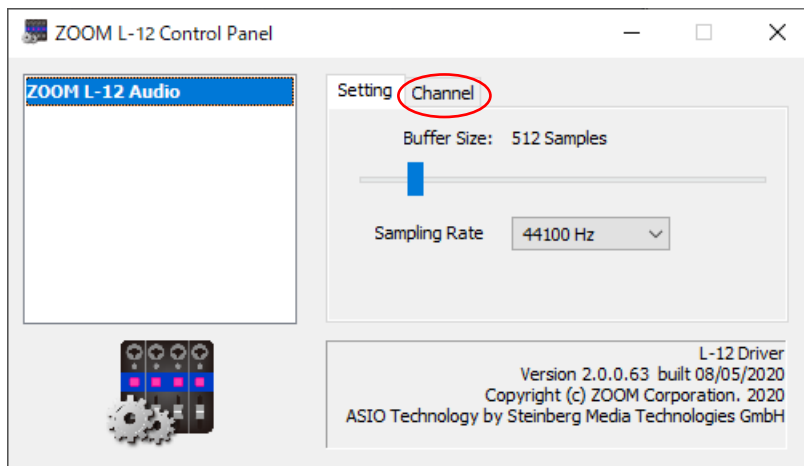

3. Select the audio interface input channel setting.

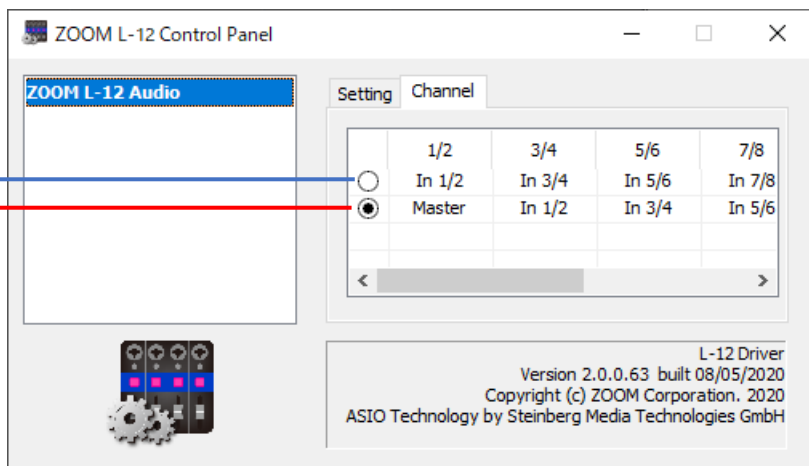

• Normal setting

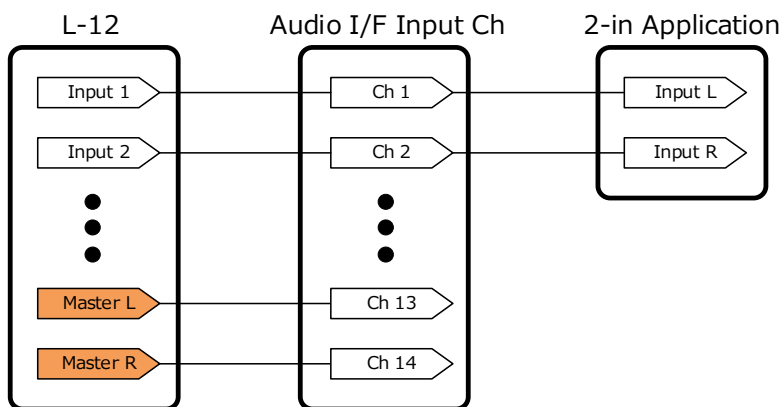

• Setting with post master fader signals input on channels 1/2

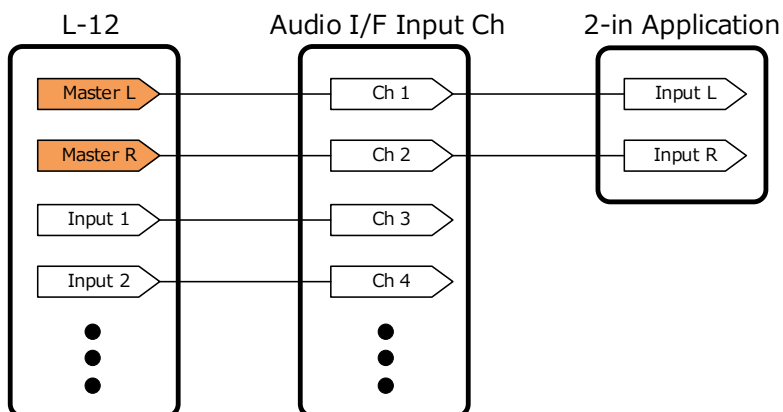

**NOTE**

This setting is saved on the computer.

**Mac**

1. Open the System Preferences, and open the ZOOM L-12 Driver or the ZOOM L-20 Driver.
2. Select the audio interface input channel setting.

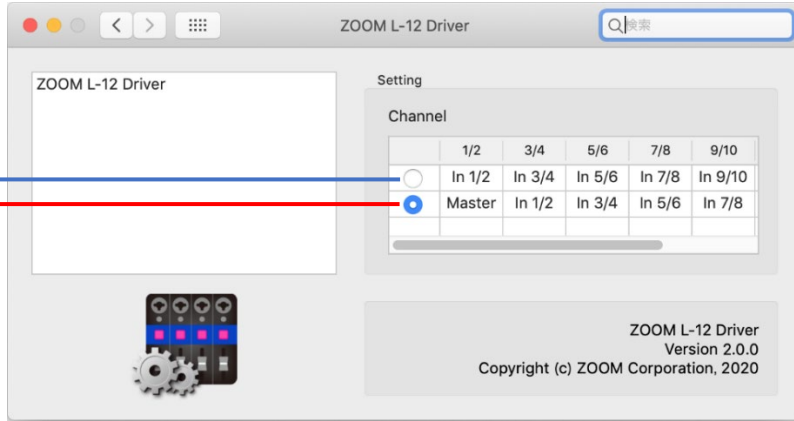

• Normal setting

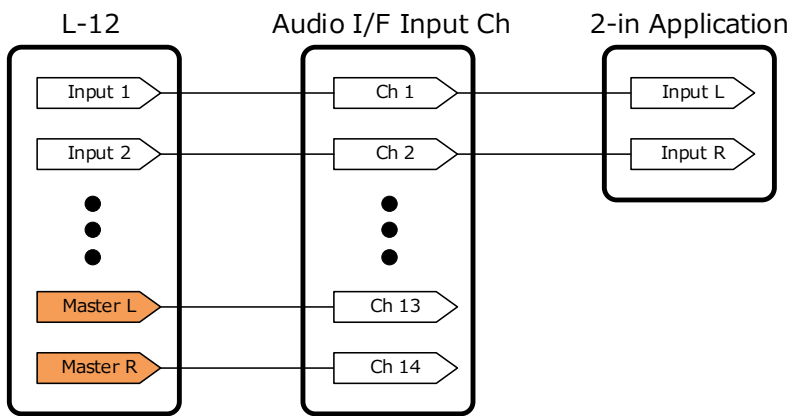

• Setting with post master fader signals input on channels 1/2

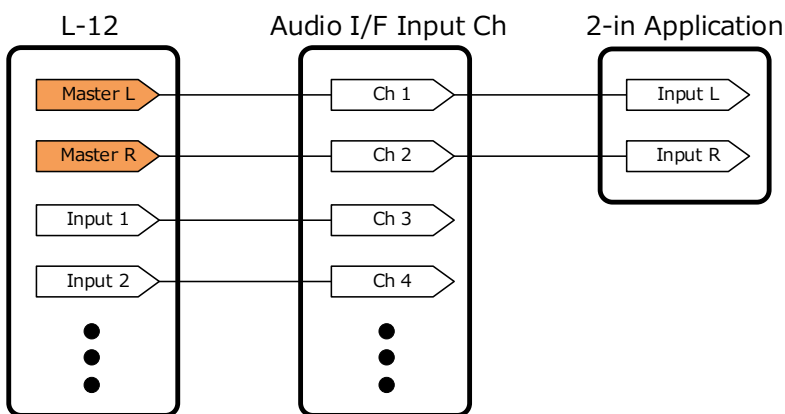

**NOTE**

This setting is saved on the computer.

© 2020 ZOOM CORPORATION

Copying or reprinting this manual in part or in whole without permission is prohibited.

© Windows® is a trademark and registered trademark of Microsoft® Corporation.

© Mac is a trademark or registered trademark of Apple Inc.

## **ZOOM CORPORATION**

4-4-3 Kanda-surugadai, Chiyoda-ku, Tokyo 101-0062 Japan

[zoomcorp.com](https://zoomcorp.com)