

[Back to Contents Page](#)

## Removing and Replacing Parts: Dell™ Dimension™ 4100 System Reference

- [Overview](#)
- [Precautionary Measures](#)
- [Recommended Tools](#)
- [Cover](#)
- [Front Panel](#)
- [Drive Cage](#)
- [3.5-Inch Front-Panel Insert](#)
- [5.25-Inch Front-Panel Insert](#)
- [Upper 3.5-Inch Drive](#)
- [Lower 3.5-Inch Drive](#)
- [3.5-Inch Floppy Drive](#)
- [5.25-Inch Drive](#)
- [Primary Hard Drive](#)
- [Secondary Hard Drive](#)
- [Power Supply](#)
- [Fan Assembly](#)
- [Card Guide Assembly](#)
- [Control Panel Board](#)
- [Cards](#)
- [Memory](#)
- [Socketed Microprocessor](#)
- [Battery](#)
- [System Board](#)

---

### Overview

Unless otherwise noted, each of the following procedures assumes:

- You have the [recommended tools](#).
- You have performed the steps listed in the Caution in [Precautionary Measures](#).
- You have [removed the computer cover](#).
- You can replace or reinstall a part by performing the removal procedure in reverse order.

---

### Precautionary Measures

Before you remove or replace parts in the computer, read the following warning and caution for your personal safety and to prevent damage to the computer from electrostatic discharge (ESD).

**CAUTION FOR YOUR PERSONAL SAFETY AND PROTECTION OF THE EQUIPMENT.**

Before you start to work on the computer, perform the following steps in the sequence listed:

1. Turn off your computer and all devices.
2. Ground yourself by touching an unpainted metal surface at the back of the computer before touching anything inside your computer.

While you work, periodically touch an unpainted metal surface on the computer to dissipate any static electricity that might harm internal components.

3. Disconnect any devices connected to the computer, including the monitor, from their electrical outlets to reduce the potential for personal injury or shock. Also, disconnect any telephone or telecommunication lines from the computer.
4. Disconnect the power cable to your computer, and then press the [power button](#) to ground the system board.

After you remove or replace parts in the computer, observe the following notice to prevent damage to the computer.

**NOTICE:** Make sure that all other system cables are connected before connecting the computer to its electrical outlet.

---

## Recommended Tools

- Small flat-blade screwdriver
- Wide flat-blade screwdriver
- #1 and #2 Phillips-head screwdrivers
- 1/4-inch nut driver
- Tweezers or long-nose pliers
- Wrist grounding strap

---

## Cover

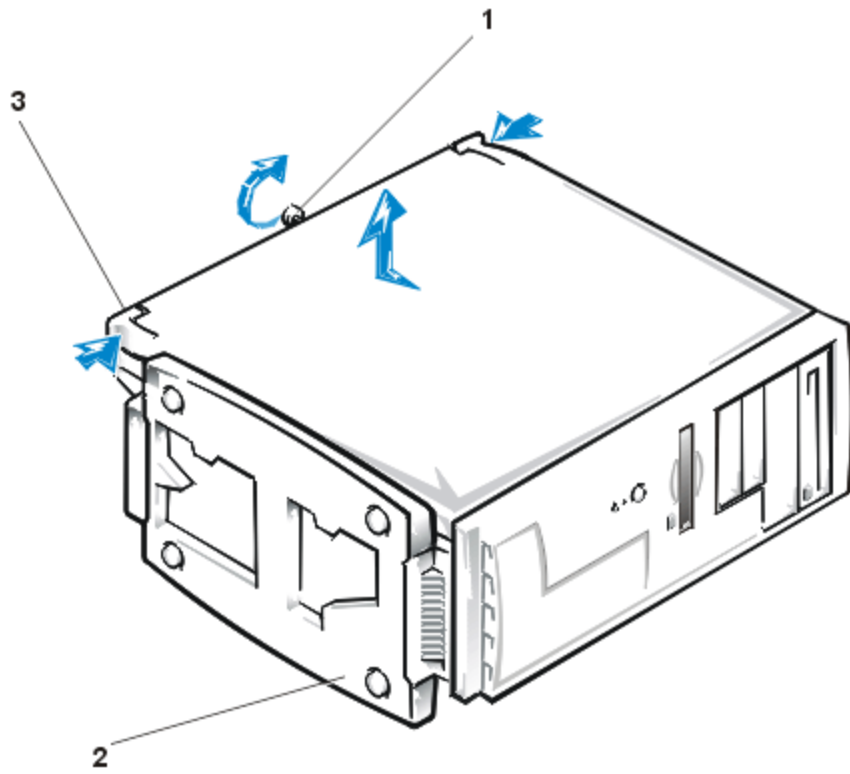

**NOTICE:** To avoid inadvertently damaging the system board while performing the following procedure, be sure that you disconnect the computer's power cable from the electrical outlet and from the back of the computer, and then press the [power button](#) before removing the computer cover. The system board continues to receive a small amount of power when the computer is turned off and attached to an electrical outlet (the [system-board power light](#) is on when power is detected.)

To remove the computer cover from a desktop or mini tower computer:

1. If you are working on a mini tower computer, lay the computer on its right side with the computer foot stand off the edge of the work surface to allow the computer to lay flat as shown in the preceding illustration.
2. Loosen the cover-mounting thumbscrew that secures the cover to the back of the computer.



*NOTE: The thumbscrew is captive and stays in the cover when loosened.*



**CAUTION:** To prevent cuts, keep your hands clear of the metal edges on the computer and fan guard as you slide the cover back.

3. Face the front of the computer. Use your thumbs to press in both cover release latches while pushing the cover backward. Move the cover back about an inch, and then lift it straight up off the computer.

If necessary, use both hands and work one side at a time.

To replace the computer cover on a desktop or mini tower computer:

1. Position the cover on the computer approximately one inch back. Slide the cover forward until it locks into place.
2. Tighten the cover-mounting thumbscrew on the back of the computer.

---

## Front Panel

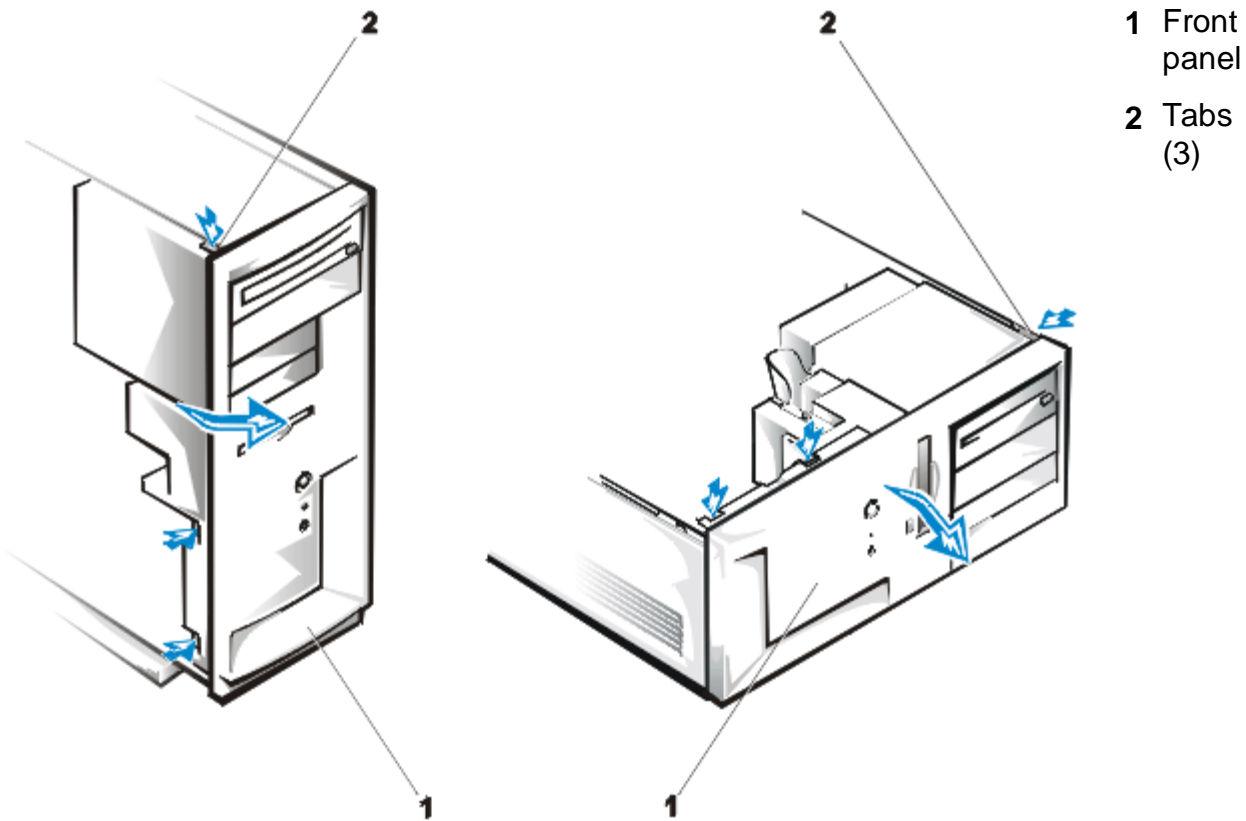

To remove the front panel:

1. With the cover removed, press in the tabs along the top and side of the front panel.
2. Swing the front panel away from the computer, disengage the hooks and carefully pull the front panel away from the computer.

---

## Drive Cage

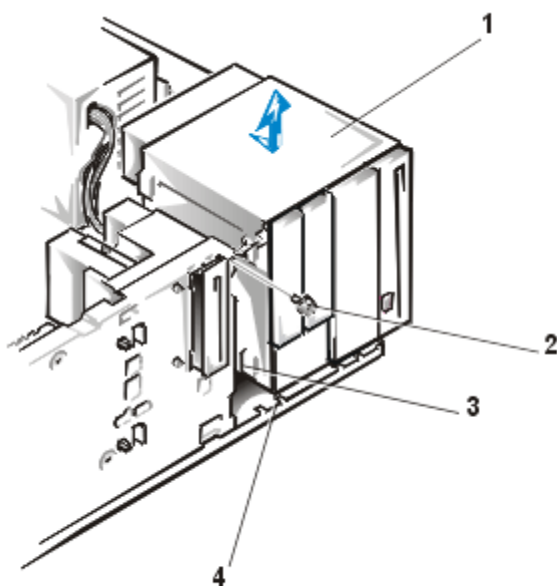

- 1 Drive cage
- 2 Screw
- 3 Drive-cage slots (6)
- 4 Tabs (6)

To remove the drive cage:

1. [Remove the front panel.](#)
2. Note the location and orientation of all cables attached to the drives in the drive cage; then disconnect the cables.
3. Remove the screw that secures the drive cage to the computer.
4. Slide the drive cage forward approximately 1/2 inch. Then lift it up (to the side for the desktop computer) and away from the computer.

The side of the computer contains three detents that secure the drive cage to the side of the computer. The drive cage may be slightly difficult to slide forward until it detaches from these detents.

---

## 3.5-Inch Front-Panel Insert

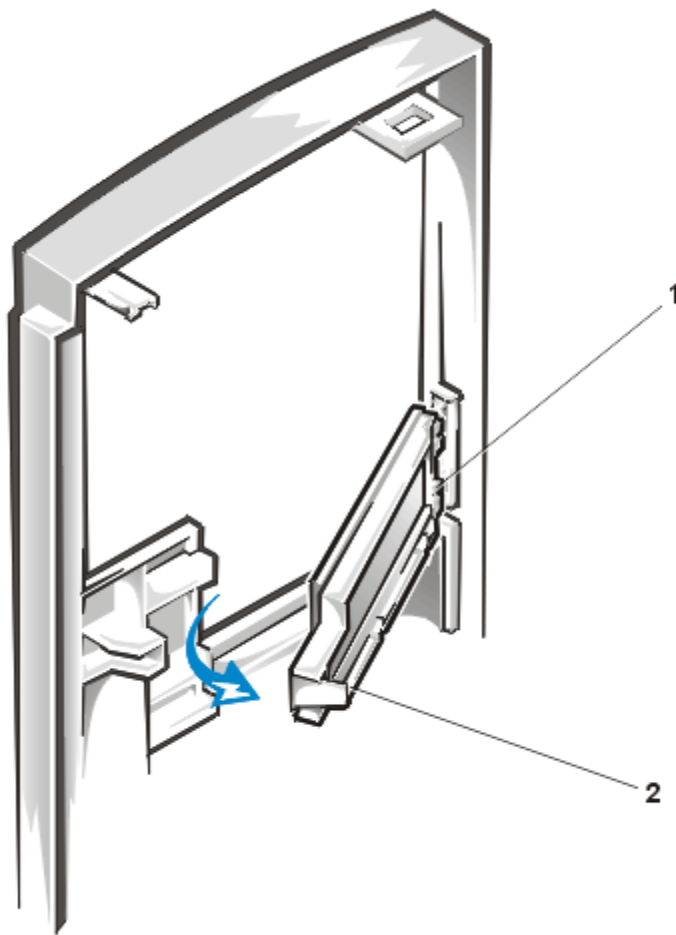

1 Tabs (2)

2 Release tab

To remove a 3.5-inch insert:

1. [Remove the front panel.](#)
2. From the back of the front panel, as shown for the mini tower computer, press the release tab to the side, rotate the insert toward you, and remove it from the bezel.

 **NOTE:** For mini tower computers, you must remove the upper insert to remove the lower insert.

---

## 5.25-Inch Front-Panel Insert

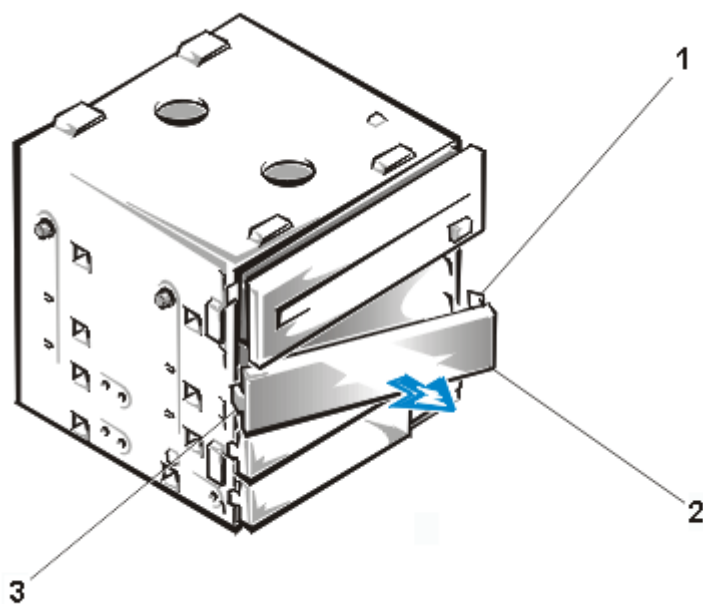

- 1 Tabs (2)
- 2 Front-panel insert
- 3 Retaining hook

The insert for the lower 5.25-inch bay is mounted to the drive cage. Press in the two tabs on the right side, and rotate the insert toward you until the retaining hook disengages from the drive cage.

Reinstall the insert by fitting the hook into the slot on the left side of the drive cage, rotating the insert into place, and snapping the tabs on the right side of the insert into the slots in the drive cage.

## Upper 3.5-Inch Drive

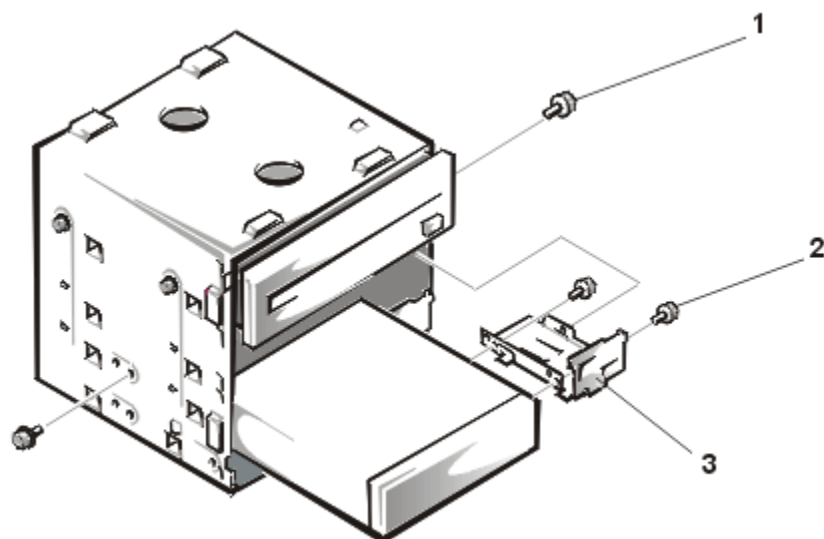

- 1 Drive-bracket mounting screw
- 2 Drive assembly screws (3)
- 3 Drive bracket

To remove the upper 3.5-inch drive:

1. [Remove the front panel.](#)



2. [Remove the drive cage.](#)
3. Remove the 6/32 x 1/4-inch screw securing the drive bracket to the drive cage, and then remove the bracket as shown.

 **NOTES:** The three screws that secure the drive to the bracket and the left side of the drive cage have 3-millimeter (mm) threads. Be sure to use the correct 3 x 5-mm screws when you secure the replacement drive to the bracket and the drive cage.

Also note which 6/32 x 1/4-inch screw was used to secure the drive bracket to the drive cage in step 3, and use the same screw when you reinstall the bracket with its attached drive.

When you replace a drive, set the jumpers on the replacement drive to match the jumpers on the drive you removed. For additional information about jumper settings on enhanced integrated drive electronics (EIDE) drives, see [EIDE Subsystem](#).

---

## Lower 3.5-Inch Drive

 **NOTE:** This drive bay is used only in mini tower computers.

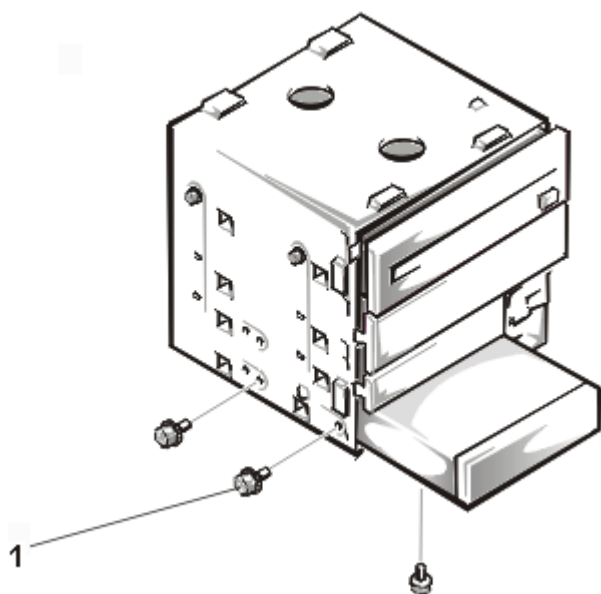

- 1 Drive-mounting screws (3)

To remove the lower 3.5-inch drive:

1. [Remove the front panel.](#)
2. [Remove the drive cage.](#)

3. Remove the three drive-mounting screws, one from the bottom and two from the left side.
4. Slide the drive out of the drive cage.

When you replace a drive, set the jumpers on the replacement drive to match the jumpers on the drive you removed. For additional information about jumper settings on EIDE drives, see [EIDE Subsystem](#).

To insert the bottom drive back into the bay, you must slide the drive over the two small grooves on the bottom of the bay.

---

## 3.5-Inch Floppy Drive

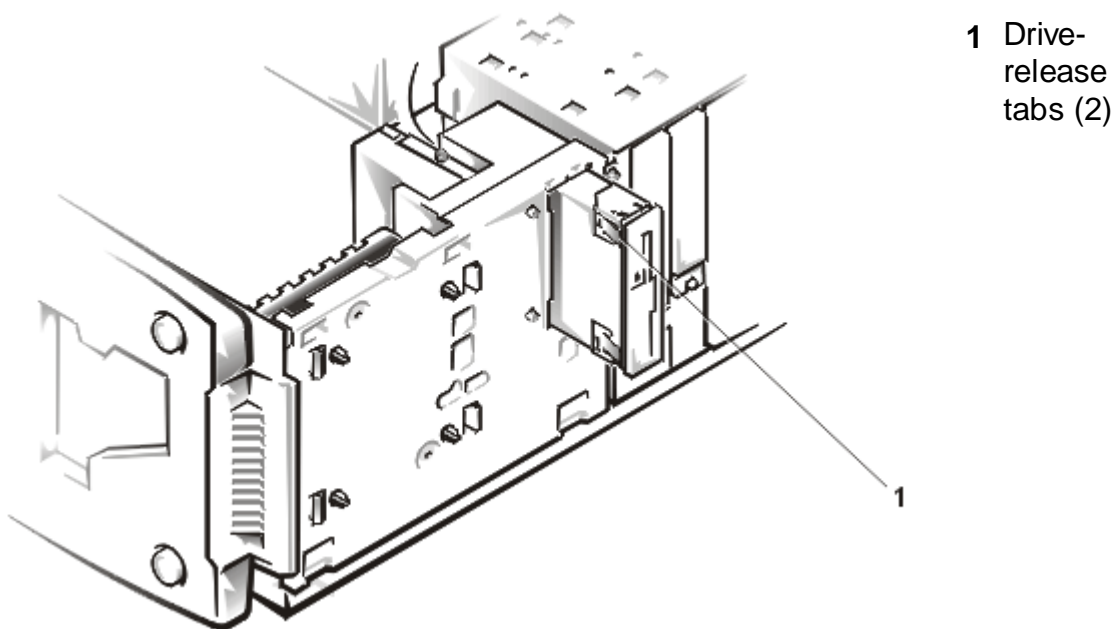

To remove the 3.5-inch floppy drive:

1. [Remove the front panel](#).
2. Disconnect the power and interface cables from the back of the floppy drive.
3. Press the two drive-release tabs, and slide the drive out of the drive bay.

Before you install the new drive, transfer the drive-release tabs to the replacement floppy drive.

---

## 5.25-Inch Drive

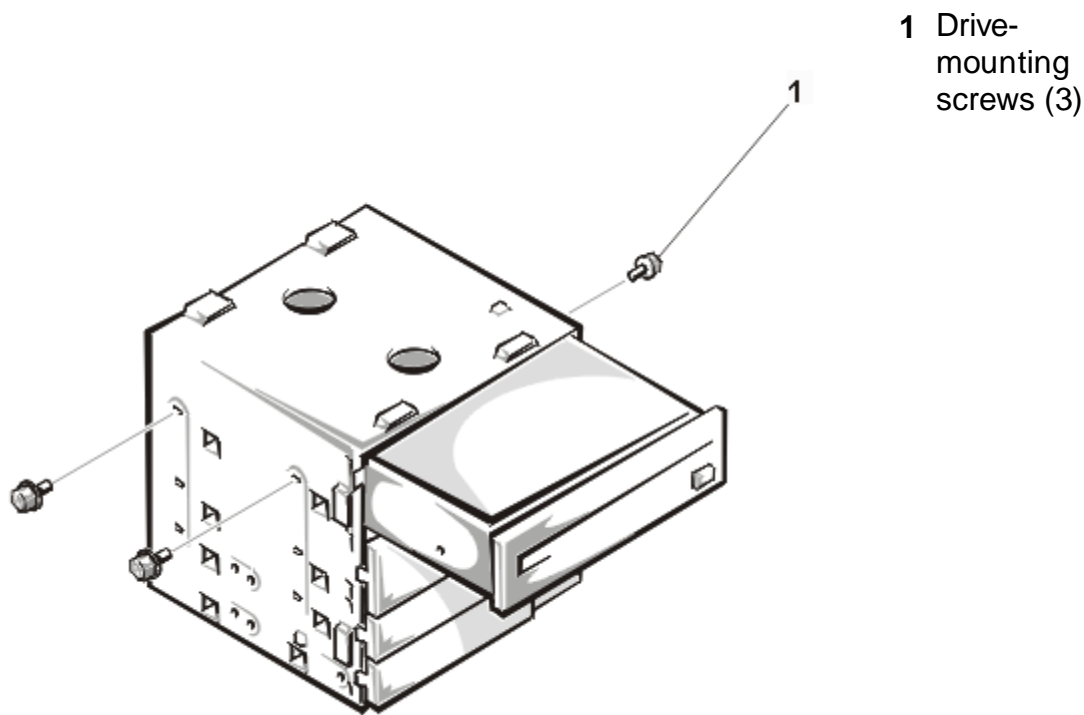

To remove the 5.25-inch drive:

1. [Remove the front panel.](#)
2. [Remove the drive cage.](#)
3. Remove the three drive-mounting screws and slide the drive out of the drive bay.

When you replace a drive, set the jumpers on the replacement drive to match the jumpers on the drive you removed. For additional information about jumper settings on EIDE drives, see [EIDE Subsystem](#).

---

## Primary Hard Drive

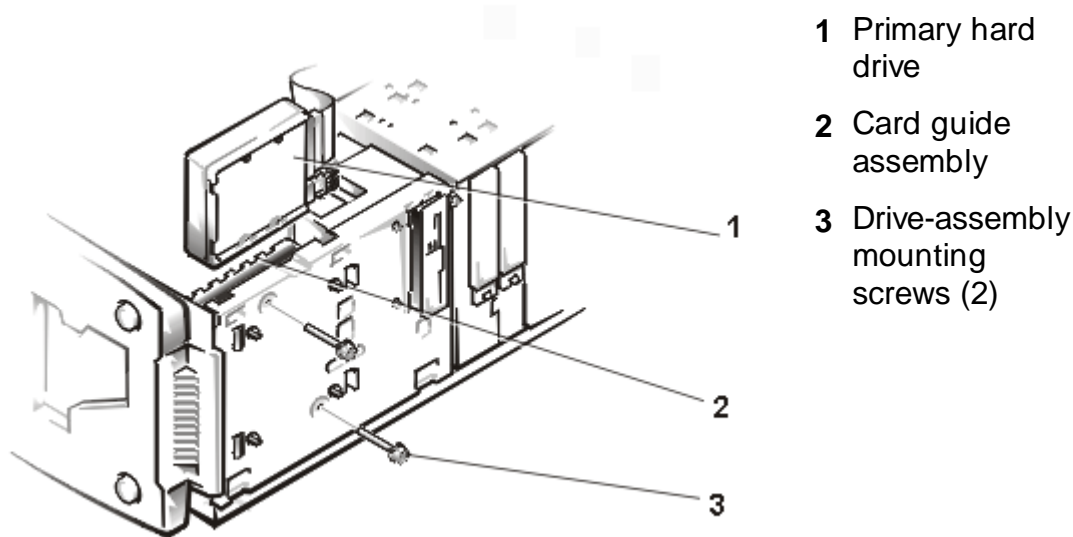

- 1 Primary hard drive
- 2 Card guide assembly
- 3 Drive-assembly mounting screws (2)

To remove the primary hard drive:

1. [Remove the front panel.](#)
2. Remove the two drive-assembly mounting screws.
3. Lift the primary hard drive out of the card guide assembly.
4. Disconnect the DC power and interface cables from the back of the drive.

To reinstall the primary hard drive, place the drive's circuit board toward the front of the computer.

When you replace a hard drive, set the jumpers on the replacement drive to match the jumpers on the drive you removed. For additional information about jumper settings on EIDE drives, see [EIDE Subsystem](#).

---

## Secondary Hard Drive

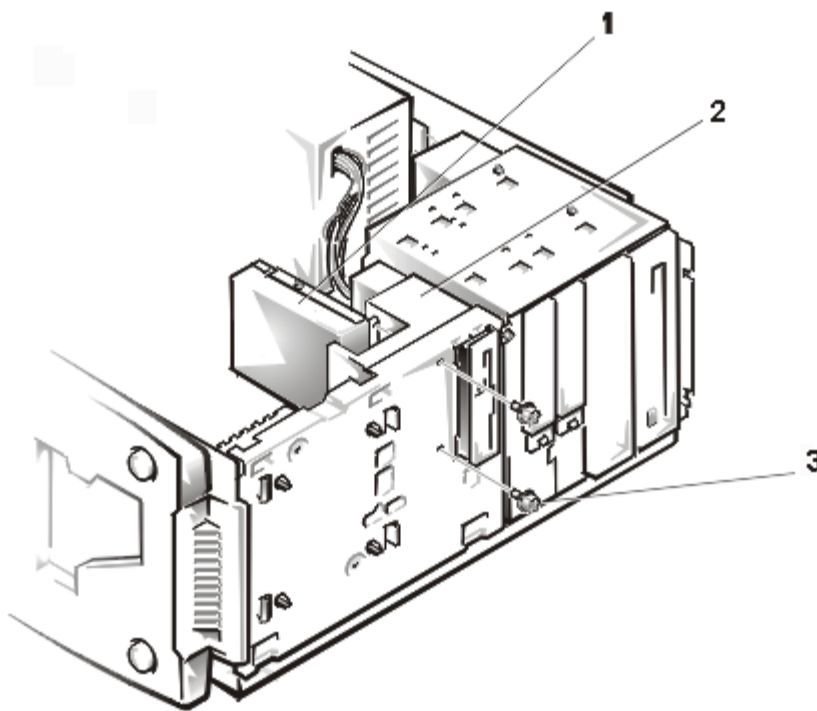

- 1 Secondary hard drive assembly
- 2 Card guide assembly
- 3 Drive-assembly mounting screws (2)

To remove the secondary hard drive:

1. [Remove the front panel.](#)
2. Disconnect the DC power and interface cables from the back of the drive.
3. Remove the two drive-assembly mounting screws.
4. Slide the hard drive assembly toward the back of the computer and lift it out.
5. Remove the drive from the drive bracket by removing the screw securing the drive to the bracket and rotating the drive out of the bracket.

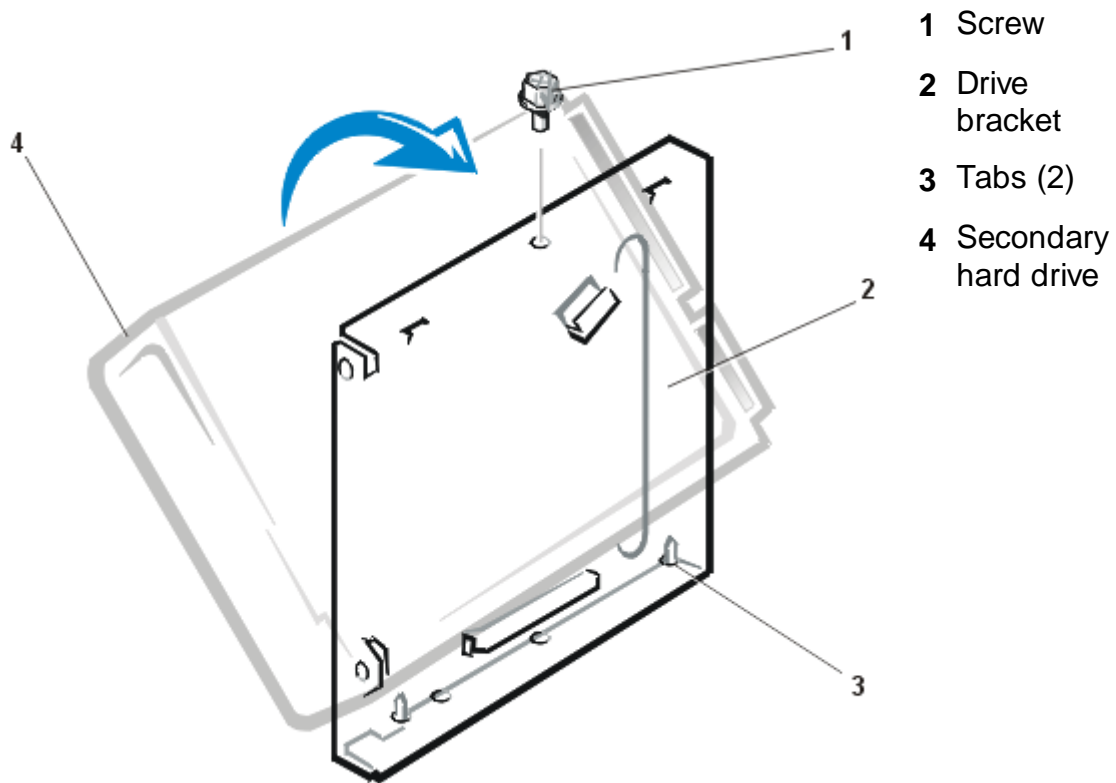

When you replace a hard drive, set the jumpers on the replacement drive to match the jumpers on the drive you removed. For additional information about jumper settings on EIDE drives, see [EIDE Subsystem](#).

As you insert the replacement hard drive into the drive bracket, make sure that the two bracket tabs fit into the mounting holes on the side of the drive.

When you reinstall the hard drive assembly, make sure that the rails on the assembly slide into the grooves of the card guide assembly.

---

## Power Supply

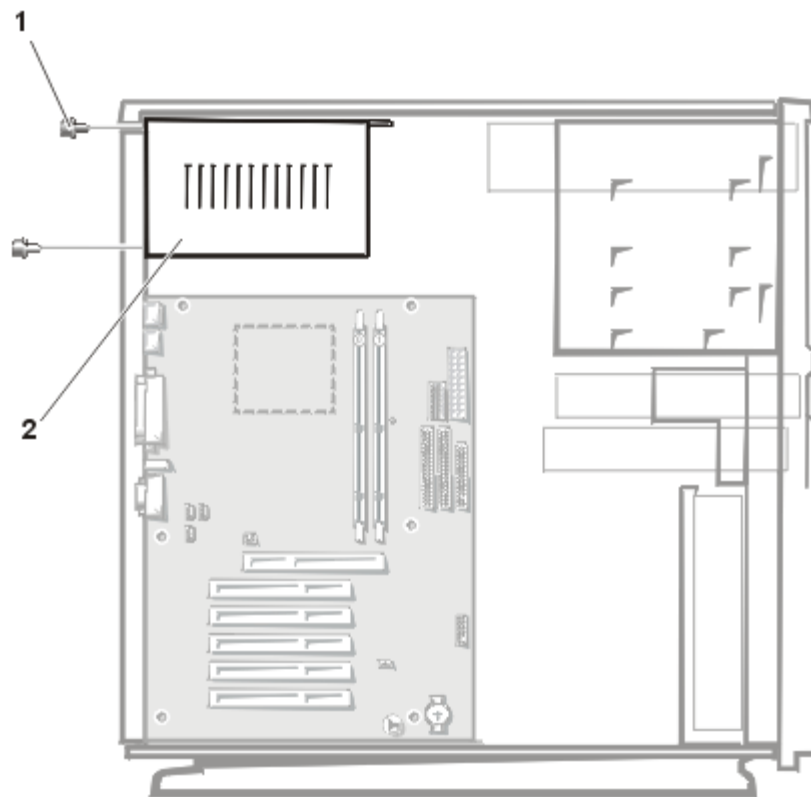

- 1 Power-supply mounting screws (2)
- 2 Power supply

To remove the power supply:

1. Disconnect the AC power cable from the power supply.
2. Disconnect the DC power cables from the [POWER connector](#) and [AUX POWER connector](#) on the system board.
3. Disconnect the DC power cables from all the drives.
4. Remove the two power-supply mounting screws from the back of the computer.
5. Lift the power supply out of the computer.

---

## Fan Assembly

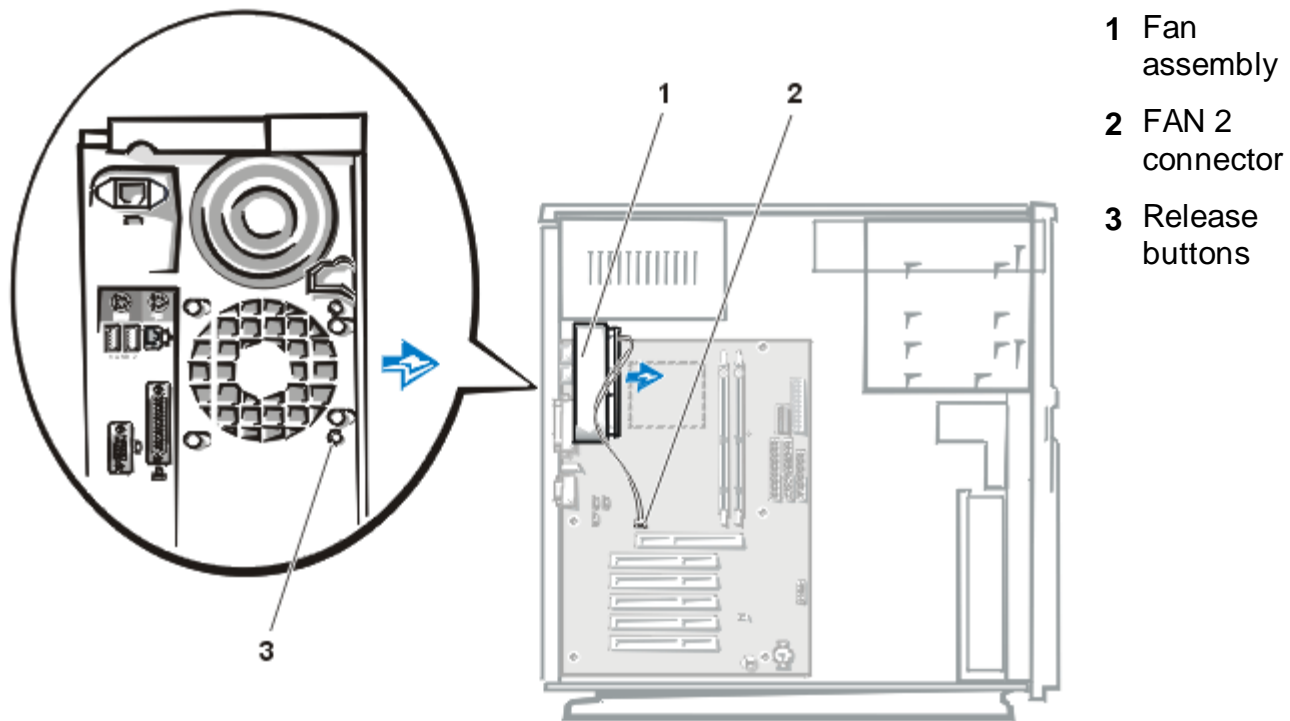

To remove the fan assembly:

1. Disconnect the fan cable from the [FAN 2 connector](#) on the system board.
2. While you push the fan assembly upward, press the two release buttons on the back of the computer and lift the fan assembly out of the computer.

---

## Card Guide Assembly



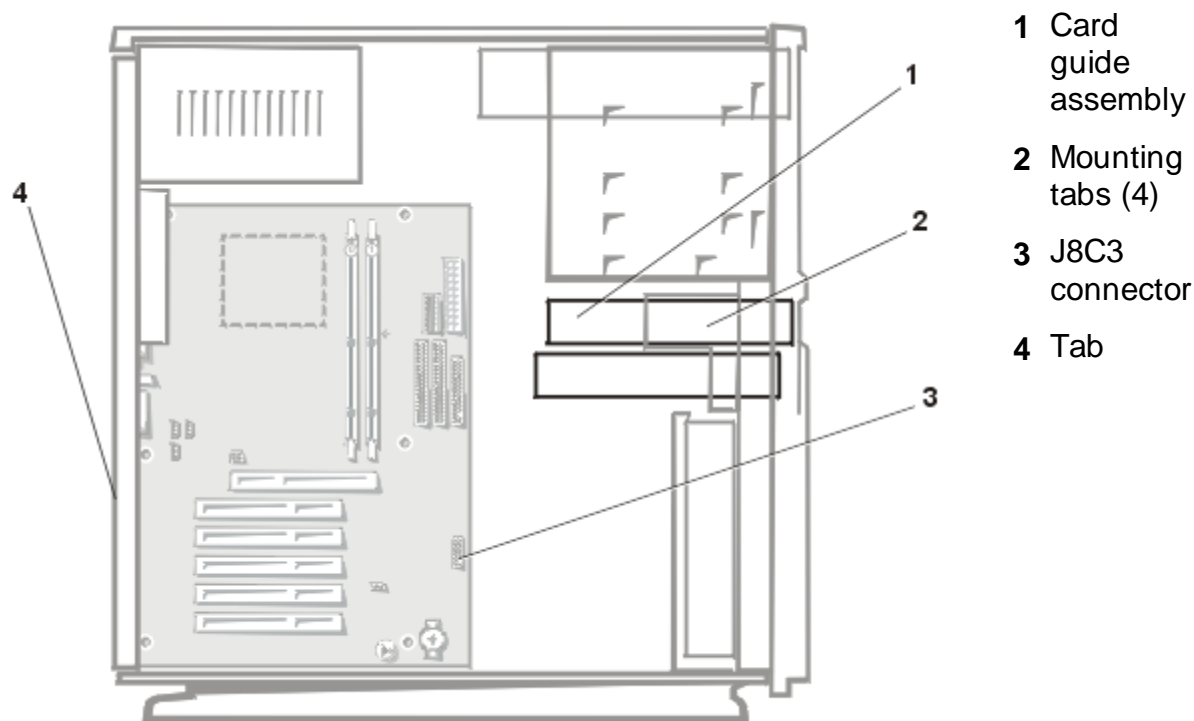

To remove the card guide assembly:

1. Disconnect any cables connected to full-length cards, and [remove these cards](#).
2. [Remove the 3.5-inch floppy drive](#).
3. [Remove the primary hard drive](#).
4. [Remove the secondary hard drive if one is present](#).
5. Disconnect the control panel cable from the [J8C3 connector](#) on the system board.
6. Press the four mounting tabs that secure the card guide assembly to the front panel, and press on the tab at the back of the card guide assembly.
7. Lift the card guide assembly, including the control panel cable, out of the computer.

---

## Control Panel Board

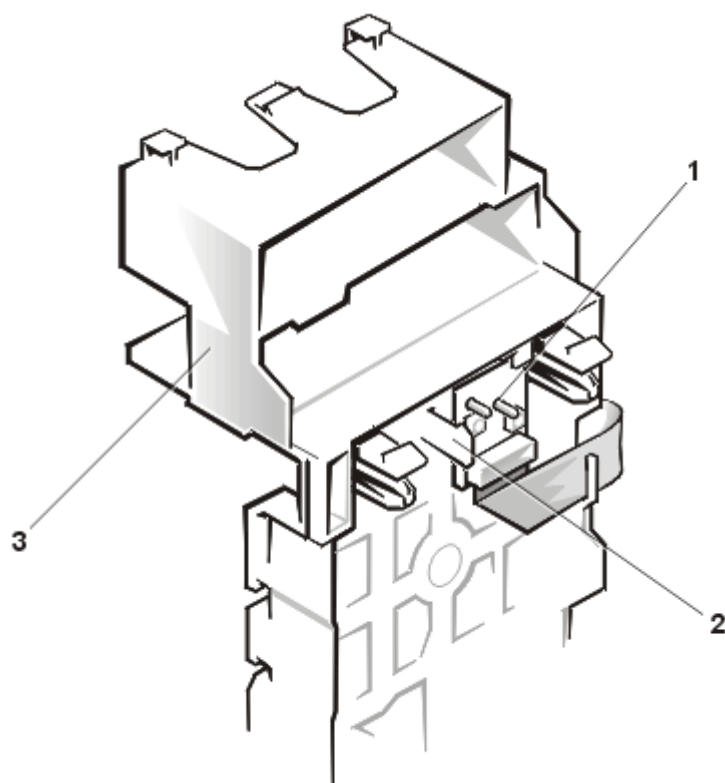

- 1 Control panel board
- 2 Mounting tab
- 3 Card guide assembly

To remove the control panel board:

1. [Remove the front panel.](#)
2. [Remove the card guide assembly.](#)
3. Press the mounting tab to release the control panel board from the card guide assembly, and remove the control panel board.

---

## Cards

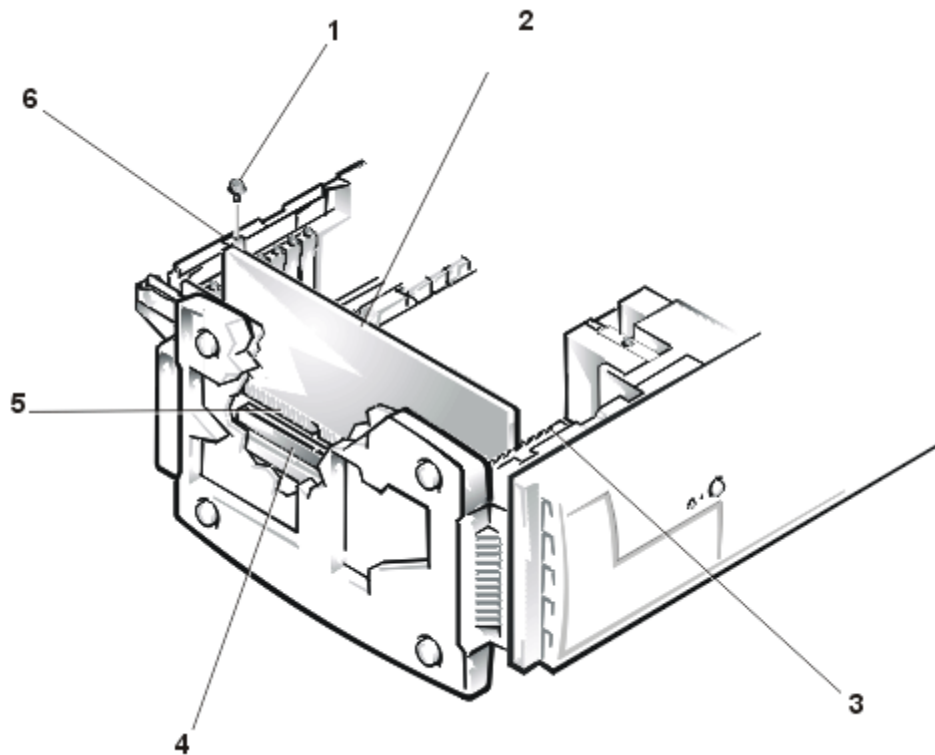

- 1 Retaining screw
- 2 Card
- 3 Card guide assembly
- 4 Card connector
- 5 Card connector
- 6 Card-mounting bracket

To remove a card:

1. Disconnect any cables from the card.
2. Remove the retaining screw from the card-mounting bracket.
3. Grasp the card by its corners, and carefully pull it out of its card connector.

 **NOTE:** Some AGP cards are secured by a clip. To remove these cards, move the clip tab away from the card with your thumb while easing the card out of its connector.

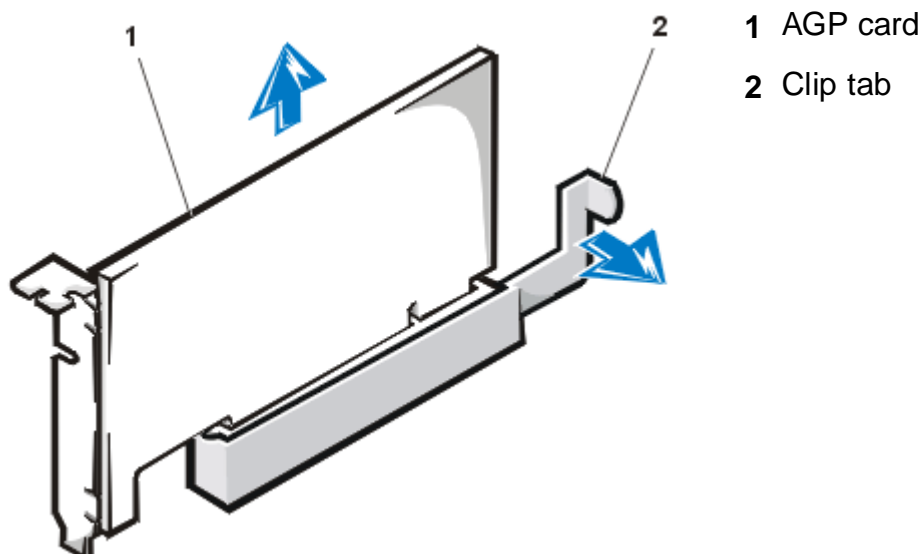

- 1 AGP card
- 2 Clip tab

## Memory

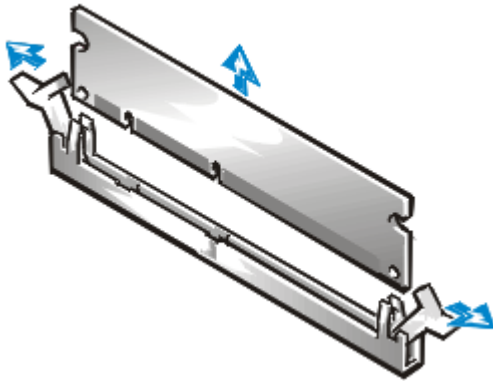

To remove a memory module, press down and out on the securing clips at each end of the socket. The module should pop up, allowing you to lift it out of the socket.

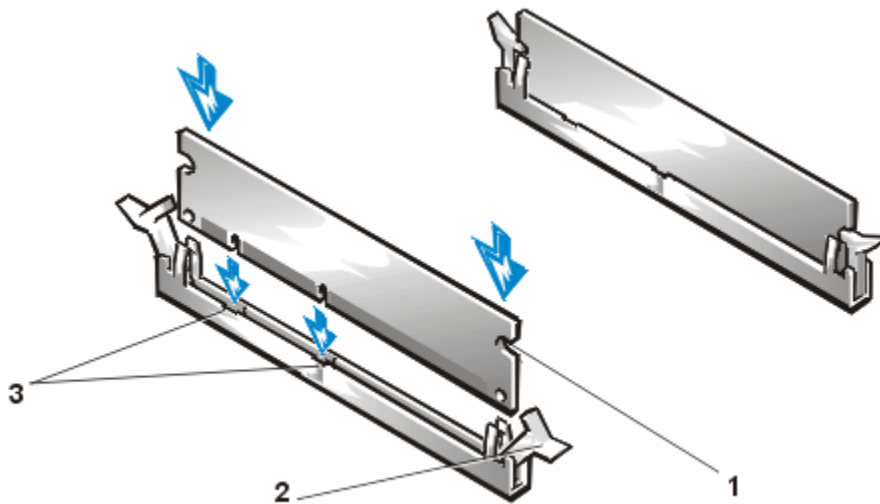

- 1 Cutout
- 2 Securing tabs (2)
- 3 Crossbars in central groove of socket (2)

 **NOTE:** In the following procedure, be sure to install only non-ECC PC133 synchronous dynamic random-access memory (SDRAM) memory modules for maximum performance.

To install a memory module:

1. Orient the memory module so that the cutouts on its edge connector align with the crossbars in the central groove of the socket.
2. Insert the module straight down into the socket, making sure that it fits into the vertical guides at each end of the socket.
3. Press firmly until the module snaps into place.

**NOTICE:** Do not press near the middle of the module. Doing so could break it.

If you have inserted the memory module correctly, the securing tabs at each end of the socket

snap into the cutouts at each end of the module.

---

## Socketed Microprocessor

**NOTICE: Do not perform this procedure unless you are upgrading the installed socketed processor and heat sink assembly with an upgrade kit. Do not reuse the installed heat sink when replacing the socketed processor. Doing so can cause the microprocessor to overheat because of an inadequate amount of thermal compound between the heat sink assembly and the socketed processor.**

**⚠ CAUTION: The socketed processor and heat sink can get extremely hot during computer operation. Be sure that the assembly has had sufficient time to cool before you touch it.**

**⚠ CAUTION: When handling the socketed processor and heat sink assembly, take care to avoid sharp edges on the heat sink.**

To remove a socketed processor from the zero-insertion force (ZIF) socket connector:

1. [Remove the computer cover.](#)
2. Remove the fan shroud by pressing its two tabs and gently lifting the shroud until it clears the fan and heat sink assemblies. Set the shroud aside.

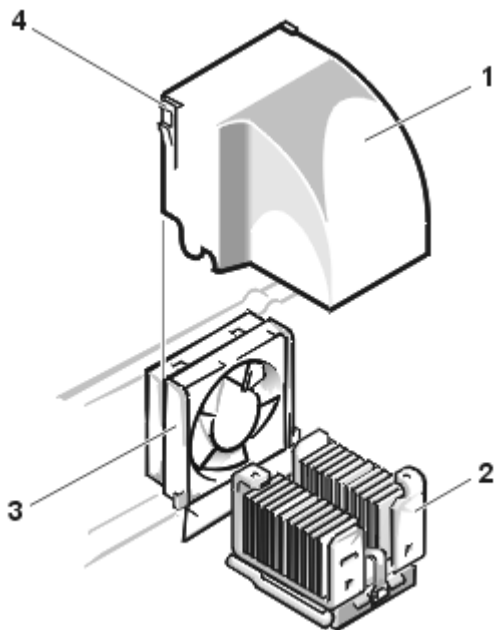

- 1 Shroud
- 2 Heat sink
- 3 Fan assembly
- 4 Fan shroud tabs (2)

3. [Remove the fan assembly.](#)
4. Remove the metal retaining clip that secures the heat sink assembly to the socketed processor by gently pushing down on the folded part of the retaining clip with a small screwdriver.

The retaining clip hooks over tabs on the sides of the ZIF socket connector.

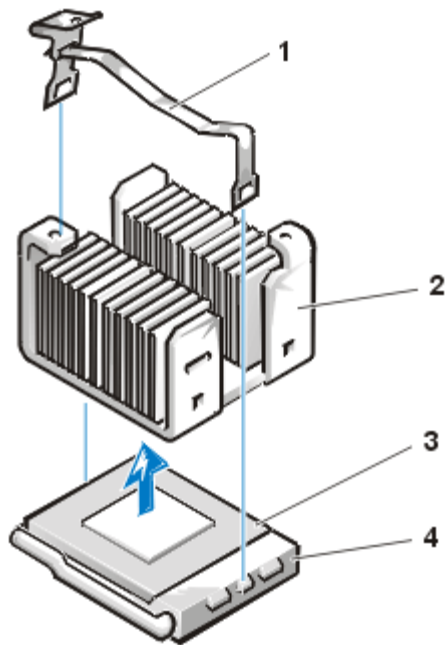

- 1 Retaining clip
- 2 Heat sink assembly
- 3 Socketed processor
- 4 ZIF socket connector

**⚠ CAUTION:** The socketed processor and heat sink assembly can get extremely hot. To avoid burns, be sure the processor and assembly have had sufficient time to cool before you touch them.

5. Remove the heat sink assembly from the socketed processor.

**NOTICE:** Be careful not to bend any of the pins when you remove the socketed processor from the ZIF socket connector. Bending the pins can permanently damage the microprocessor.

6. Detach and lift the socketed processor away from the ZIF socket connector.

The ZIF socket connector has a lever-type handle that secures and releases the socketed processor from the ZIF socket connector.

- a. Pull the socket release lever straight out until the socketed processor releases.
- b. Remove the socketed processor from the socket connector.

Leave the release lever extended so that the socket connector is ready for the installation of a socketed processor.

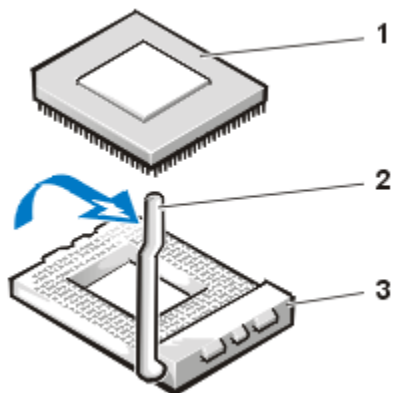

- 1 Socketed processor
- 2 Socket release lever
- 3 ZIF socket connector

To replace the socketed processor and heat sink assembly:

1. Unpack the new socketed processor.

**NOTICE: You must position the socketed processor correctly in the ZIF socket connector to avoid permanent damage to the microprocessor and the computer when you turn on the computer.**

2. Install the socketed processor in the ZIF socket connector.
  - a. If the release lever on the ZIF socket connector is not all the way out, move it to that position now.
  - b. Align pin 1 (the beveled corner) of the socketed processor and pin 1 of the ZIF socket connector.
  - c. Set the socketed processor lightly in the socket, making sure that all the pins are headed into the correct holes.

Because your computer uses a ZIF socket connector, there is no need to use force (which could bend the pins if the socketed processor is misaligned).

- d. When the socketed processor is positioned correctly, press it with minimal pressure to fully seat it in the ZIF socket connector.
- e. When the socketed processor is fully seated, pivot the release lever back toward the system board until it snaps into place, securing the microprocessor.

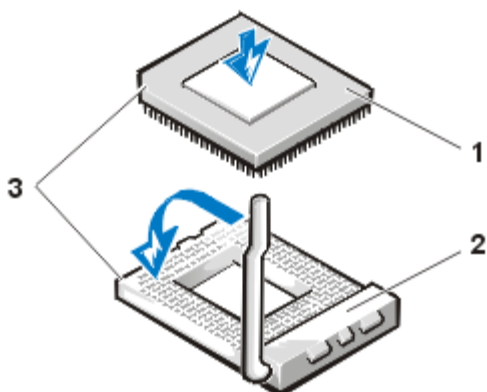

- 1 Socketed processor
- 2 ZIF socket connector
- 3 Pin 1 (alignment corner)

3. Unpack the heat sink included in your upgrade kit.

**NOTICE: Do not reuse the old heat sink when replacing the socketed processor. Doing so can cause the microprocessor to overheat because of an inadequate amount of thermal compound between the heat sink assembly and the microprocessor package.**

4. Replace the heat sink assembly.
  - a. Peel the release liner from the adhesive tape that is attached to the bottom of the new heat sink assembly.
  - b. Place the heat sink assembly on top of the socketed processor.
  - c. Orient the metal retaining clip as shown in the following illustration, and hook the unhinged end of the clip over the tab on the top edge of the ZIF socket connector.
  - d. Press down on the hinged end of the clip to snap the clip over the tab on the bottom edge of the ZIF socket connector.

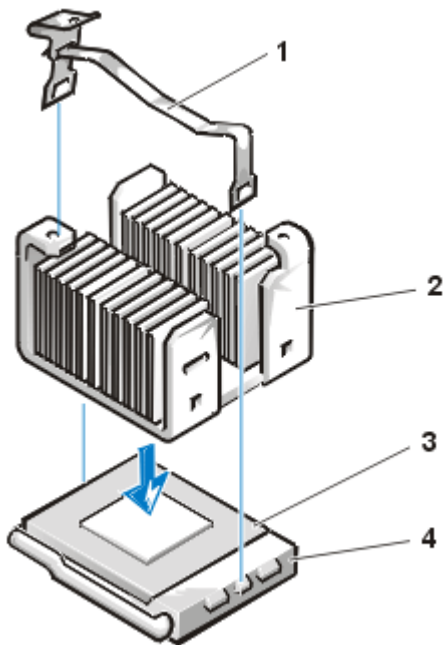

- 1 Retaining clip
- 2 Heat sink assembly
- 3 Socketed processor
- 4 ZIF socket

5. [Replace the fan assembly.](#)

6. Place the fan shroud over the fan assembly and heat sink assembly. Then gently press down the shroud until the two fan shroud tabs snap into the two slots on top of the fan assembly.
7. Replace the computer cover, and reconnect the computer to an electrical outlet.
8. Insert a diskette copy of the Dell Diagnostics into the diskette drive, and restart the computer. Run the **System Set** test group in the Dell Diagnostics.

If the tests do not complete successfully, see "Contacting Dell" in the *Solutions Guide* for instructions on obtaining technical assistance.



## Battery

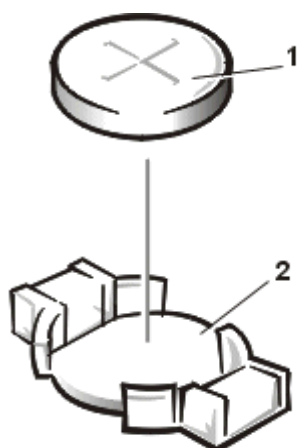

- 1 Battery
- 2 Battery socket (BATTERY)

**⚠ CAUTION:** There is a danger of the new battery exploding if it is incorrectly installed. Replace the battery only with the same or equivalent type recommended by the manufacturer. Discard used batteries according to the manufacturer's instructions.

To remove the 3-volt (V), CR2032 coin-cell battery:

1. Dell recommends that you write down the system configuration information in the system setup program screens for future reference.
2. [Remove the computer cover.](#)

**NOTICE:** Do not use a metal object to remove the battery from the socket when you perform the next step. A metal object may short out the battery or the socket and damage the system board.

**NOTICE:** If you pry out the battery with a blunt object, insert the object between the battery and the socket. Otherwise, you may damage the system board by prying off the socket or by breaking circuit traces on the system board.

3. Pry the battery out of its socket (BATTERY) with your fingers or with a blunt, nonconductive object such as a plastic screwdriver.

To replace the battery:

1. Install the new battery with the "+" side facing up.
2. Start the [system setup program](#), and reset the [System Date and System Time settings](#).
3. Compare the system configuration settings and restore any system configuration information that was lost when you replaced the battery.

## System Board

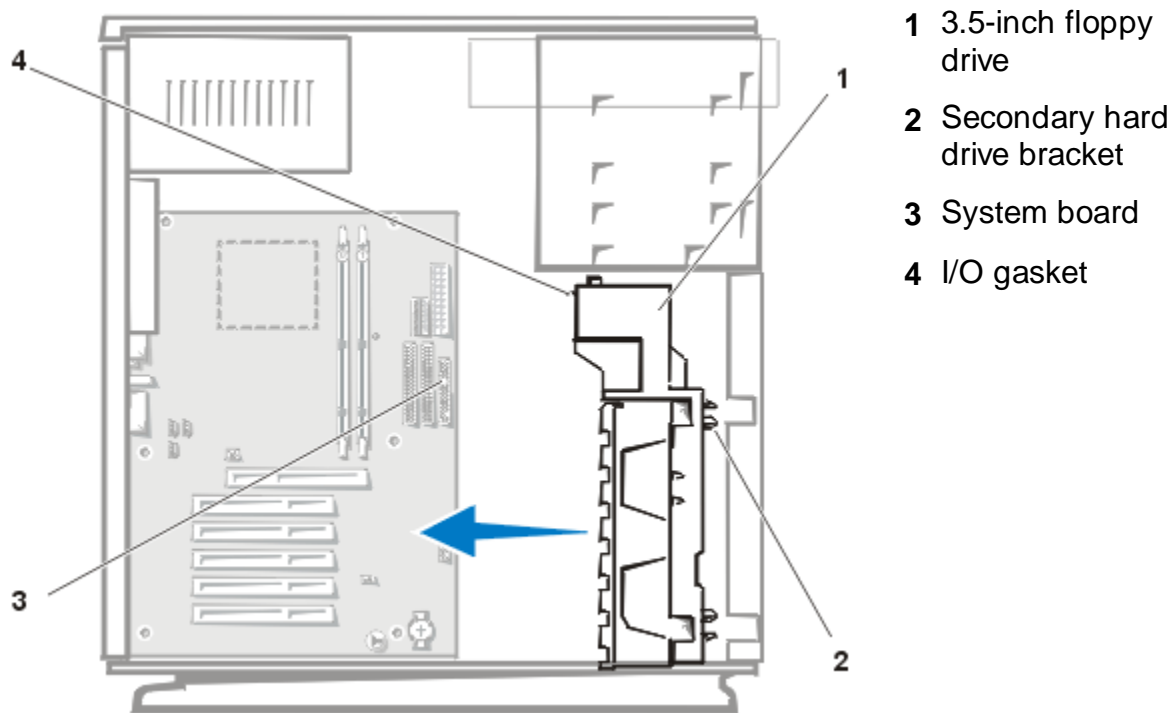

To remove the system board:

1. If possible, enter the [system setup program](#) and write down the system setup program screen information before you turn off the computer because you will have to restore the configuration information after the system board is replaced.
2. Disconnect any cables attached to the [back of the computer](#).
3. Disconnect any cables connected to cards, and [remove these cards](#).
4. Disconnect all internal cables from the [system board](#).
5. [Remove the socketed processor and heat sink assembly](#).
6. Remove the system-board mounting screw from the back of the computer, as shown in the following figure.

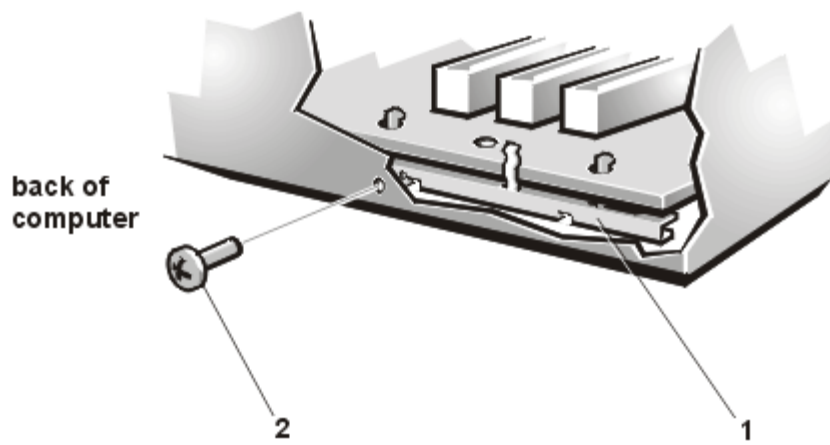

- 1** System-board mounting bracket
- 2** Mounting screw

7. Lift the system board from the three plastic standoffs that secure the system board to the computer.
8. Carefully lift the system board out from the I/O gasket (see [System Board](#)), and remove the board from the computer.

 **NOTE:** You may need to slide the board toward the front of the computer to clear the hooked standoffs before you can lift the board from the computer.

9. Remove the mounting bracket from the back of the system board as shown in the following figure.

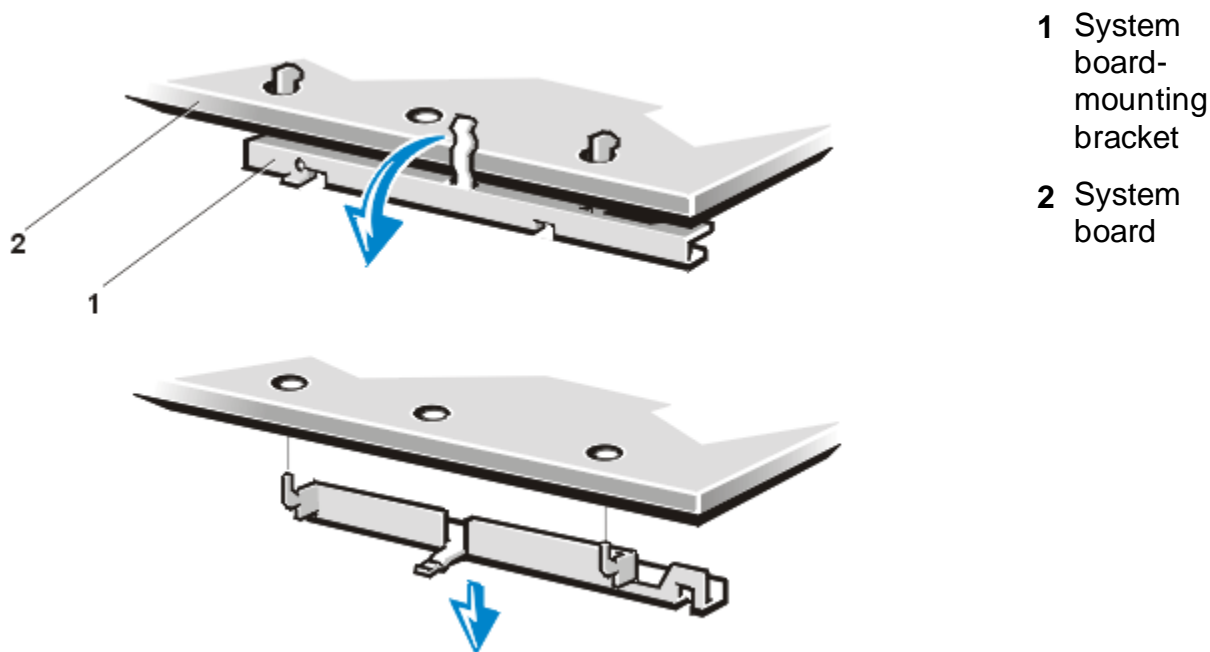

Before you install a replacement system board:

1. [Install the socketed processor and heat sink assembly.](#)
2. Transfer the memory modules to the new system board.

When you install a replacement system board, angle the back of the board downward and carefully align the connectors on the back edge of the board with the cutouts in the I/O gasket (see [System Board](#)). When properly aligned, the board connectors slide into the I/O gasket as you lower the board into position in the computer and reseal it on the three plastic standoffs. Then replace the system-board mounting screw.

 **NOTE:** The system-board mounting screw pulls the board against the I/O gasket to prevent electromagnetic interference (EMI) leakage.

After you install the replacement system board, replace the cards that you removed from the old

system board.

When you reconnect the cables to a system board with built-in sound, connect the CD drive sound cable to the [CD IN connector](#) on the system board. The [TELEPHONY connector](#) may be used with a modem.

To configure the computer after you install a replacement board:

1. Install the jumper plug on pins 2 and 3 of [configuration jumper](#) BIOS CONF to select Maintenance mode.

2. Replace the cover and start the computer.

The computer automatically starts the [system setup program](#), adds the **Maintenance** option to the menu bar, and displays the **Maintenance** screen.

3. Select **Clear All Passwords**, and press <Enter> twice.
4. Press <F10> to exit the system setup program and save any changes you made.
5. Turn off the computer, remove the computer cover, and replace the jumper plug on pins 1 and 2 of [configuration jumper](#) BIOS CONF to select Normal mode operation.
6. Replace the cover and boot the computer.
7. Reenter the system setup program, and reset the system configuration information.

---

[Back to Contents Page](#)